



LOW POWER QUAD VOLTAGE COMPARATORS

- WIDE SINGLE SUPPLY VOLTAGE RANGE OR DUAL SUPPLIES FOR ALL DEVICES : +2V TO +36V OR $\pm 1V$ TO $\pm 18V$
- VERY LOW SUPPLY CURRENT (1.1mA) INDEPENDENT OF SUPPLY VOLTAGE (1.4mW/comparator at +5V)
- LOW INPUT BIAS CURRENT : 25nA TYP
- LOW INPUT OFFSET CURRENT : $\pm 5nA$ TYP
- LOW INPUT OFFSET VOLTAGE : $\pm 1mV$ TYP
- INPUT COMMON-MODE VOLTAGE RANGE INCLUDES GROUND
- LOW OUTPUT SATURATION VOLTAGE : 250mV TYP; ($I_o = 4mA$)
- DIFFERENTIAL INPUT VOLTAGE RANGE EQUAL TO THE SUPPLY VOLTAGE
- TTL, DTL, ECL, MOS, CMOS COMPATIBLE OUTPUTS

DESCRIPTION

These devices consist of four independent precision voltage comparators with an offset voltage specifications as low as 2mV max for LM339A, LM239A and LM139A. All these comparators were designed specifically to operate from a single power supply over a wide range of voltages. Operation from split power supplies is also possible.

These comparators also have a unique characteristic in that the input common-mode voltage range includes ground even though operated from a single power supply voltage.

PIN CONNECTIONS (top view)

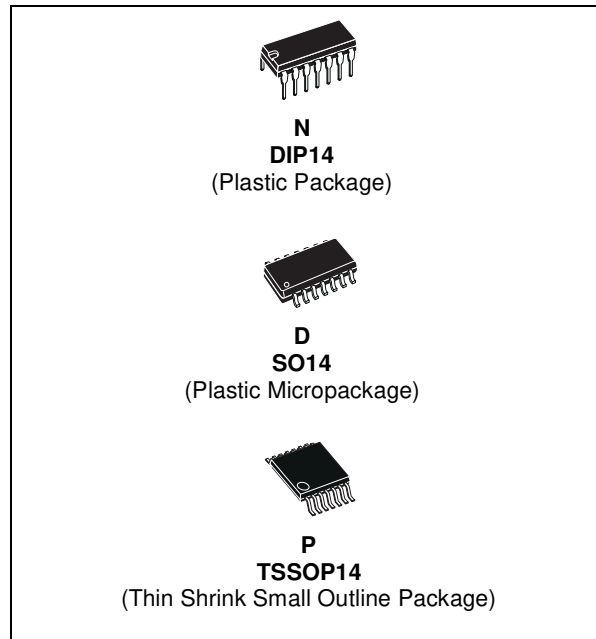
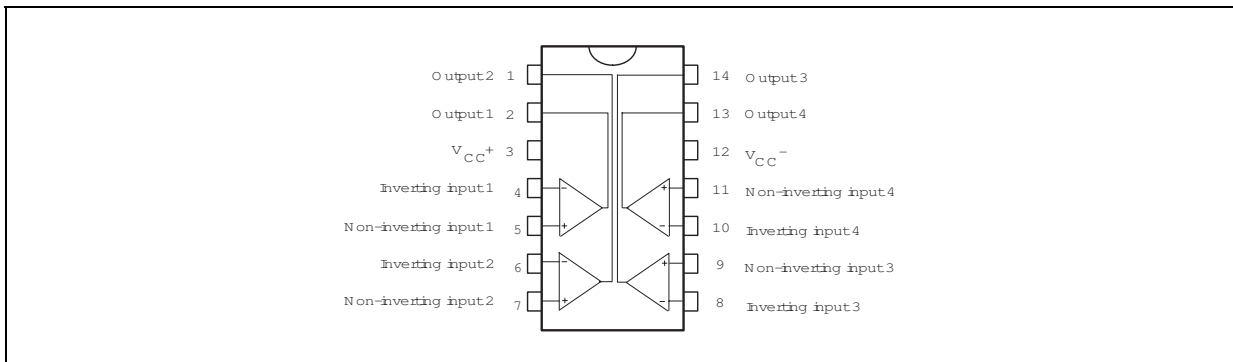

ORDER CODE

Part Number	Temperature Range	Package		
		N	D	P
LM139,A	-55°C, +125°C	•	•	•
LM239,A	-40°C, +105°C	•	•	•
LM339,A	0°C, +70°C	•	•	•

Example : LM139AN

N = Dual in Line Package (DIP)
D = Small Outline Package (SO) - also available in Tape & Reel (DT)
P = Thin Shrink Small Outline Package (TSSOP) - only available in Tape & Reel (PT)

SCHEMATIC DIAGRAM (1/4 LM139)

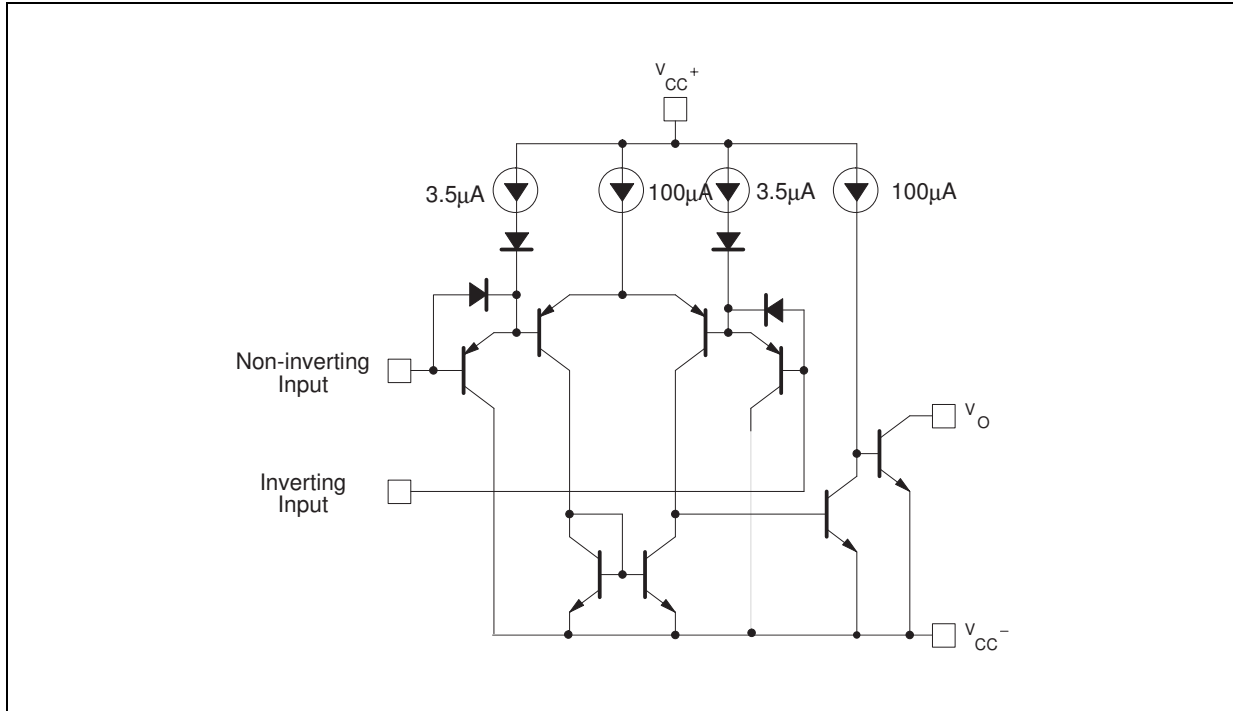

ABSOLUTE MAXIMUM RATINGS

Symbol	Parameter	Value	Unit	
V_{CC}	Supply voltage	± 18 or 36	V	
V_{id}	Differential Input Voltage	± 36	V	
V_i	Input Voltage	-0.3 to +36	V	
	Output Short-circuit to Ground - note 1)	Infinite		
P_d	Power Dissipation 2)	DIP14 SO14 TSSOP14	1500 830 710	mW
T_{stg}	Storage Temperature Range	-65 to +150	°C	
T_j	Junction Temperature	+150	°C	

1. Short-circuits from the output to V_{CC}^+ can cause excessive heating and eventual destruction. The maximum output current is approximately 20mA independent of the magnitude of V_{CC}^+ .

2. P_d is calculated with $T_{amb} = +25^\circ\text{C}$, $T_j = +150^\circ\text{C}$ and $R_{thja} = 80^\circ\text{C/W}$ for DIP14 package
 $= 150^\circ\text{C/W}$ for SO14 package
 $= 175^\circ\text{C/W}$ for TSSOP14 package

OPERATING CONDITIONS ($T_{amb} = 25^\circ\text{C}$)

Symbol	Parameter	Value	Unit	
V_{CC}	Supply Voltage	2 to 32 ± 1 to ± 16	V	
V_{icm}	Common Mode Input Voltage Range	0 to $(V_{CC}^+ - 1.5)$	V	
T_{oper}	Operating Free-air Temperature Range	LM139, LM139A LM239, LM239A LM339, LM339A	-55, +125 -40, +105 0, +70	°C

ELECTRICAL CHARACTERISTICS

 $V_{CC}^+ = +5V$, $V_{CC}^- = GND$, $T_{amb} = +25^\circ C$ (unless otherwise specified)

Symbol	Parameter	LM139A - LM239A LM339A			LM139- LM239 LM339			Unit
		Min.	Typ.	Max.	Min	Typ.	Max.	
V_{io}	Input Offset Voltage - note ¹⁾ $T_{amb} = +25^\circ C$ $T_{min} \leq T_{amb} \leq T_{max}$		1	2 4		1	5 9	mV
I_{io}	Input Offset Current $T_{amb} = +25^\circ C$ $T_{min} \leq T_{amb} \leq T_{max}$		3	25 100		5	50 150	nA
I_{ib}	Input Bias Current (I^+ or I^-) - note ²⁾ $T_{amb} = +25^\circ C$ $T_{min} \leq T_{amb} \leq T_{max}$		25	100 300		25	250 400	nA
A_{vd}	Large Signal Voltage Gain $V_{CC} = 15V$, $R_L = 15k\Omega$, $V_o = 1V$ to $11V$	50	200		50	200		V/mV
I_{CC}	Supply Current (all comparators) $V_{CC} = +5V$, no load $V_{CC} = +30V$, no load		1.1 1.3	2 2.5		1.1 1.3	2 2.5	mA
V_{icm}	Input Common Mode Voltage Range - note ³⁾ $V_{CC} = 30V$ $T_{amb} = +25^\circ C$ $T_{min} \leq T_{amb} \leq T_{max}$	0 0		$V_{CC}^+ - 1.5$ $V_{CC}^+ - 2$	0 0		$V_{CC}^+ - 1.5$ $V_{CC}^+ - 2$	V
V_{id}	Differential Input Voltage -note ⁴⁾			V_{CC}^+			V_{CC}^+	V
V_{OL}	Low Level Output Voltage $V_{id} = -1V$, $I_{sink} = 4mA$ $T_{amb} = +25^\circ C$ $T_{min} \leq T_{amb} \leq T_{max}$		250	400 700		250	400 700	V
I_{OH}	High Level Output Current ($V_{id} = 1V$) $V_{CC} = V_o = 30V$ $T_{amb} = +25^\circ C$ $T_{min} \leq T_{amb} \leq T_{max}$		0.1	1		0.1	1	nA μA
I_{sink}	Output Sink Current $V_{id} = 1V$, $V_o = 1.5V$	6	16		6	16		mA
t_{re}	Response Time - note ⁵⁾ $R_L = 5.1k\Omega$ connected to V_{CC}^+		1.3			1.3		μs
t_{rel}	Large Signal Response Time $R_L = 5.1k\Omega$ connected to V_{CC}^+ , $e_i = TTL$, $V_{(ref)} = +1.4v$		300			300		ns

- At output switch point, $V_o \approx 1.4V$, $R_s = 0$ with V_{CC}^+ from 5V to 30V, and over the full common-mode range (0V to $V_{CC}^+ - 1.5V$).
- The direction of the input current is out of the IC due to the PNP input stage. This current is essentially constant, independent of the state of the output, so no loading charge exists on the reference of input lines.
- The input common-mode voltage of either input signal voltage should not be allowed to go negative by more than 0.3V. The upper end of the common-mode voltage range is $V_{CC}^+ - 1.5V$, but either or both inputs can go to +30V without damage
- The response time specified is for a 100mV input step with 5mV overdrive. For larger overdrive signals 300ns can be obtained
- Positive excursions of input voltage may exceed the power supply level. As long as the other voltage remains within the common-mode range, the comparator will provide a proper output state. The low input voltage state must not be less than -0.3V (or 0.3V below the negative power supply, if used).

SUPPLY CURRENT versus SUPPLY VOLTAGE

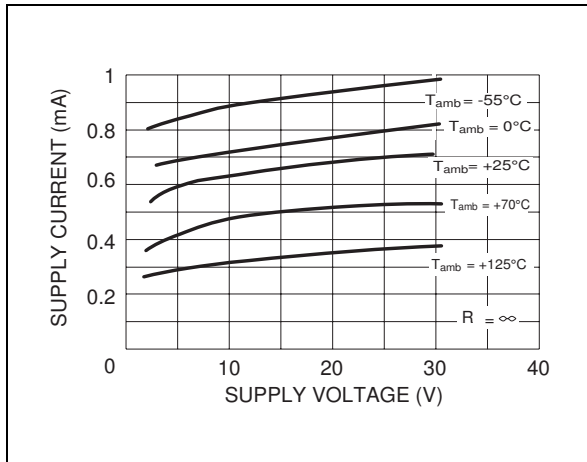

INPUT CURRENT versus SUPPLY VOLTAGE

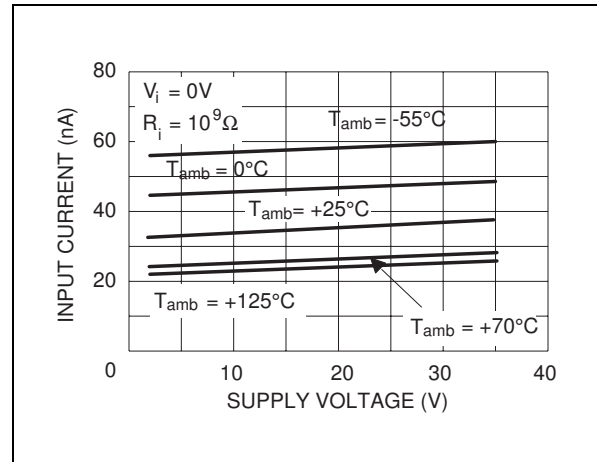

OUTPUT SATURATION VOLTAGE versus OUTPUT CURRENT

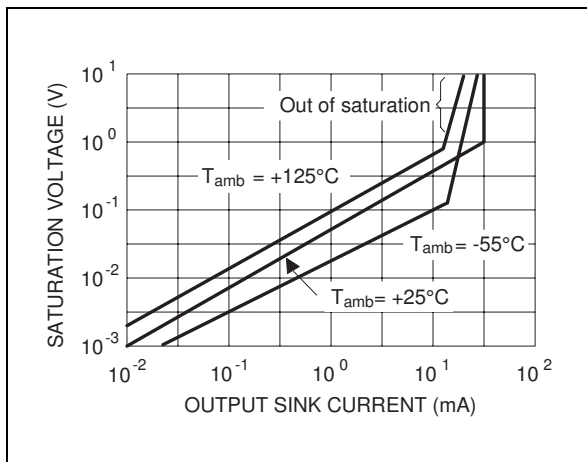

RESPONSE TIME FOR VARIOIOUS INPUT OVERDRIVES - NEGATIVE TRANSITION

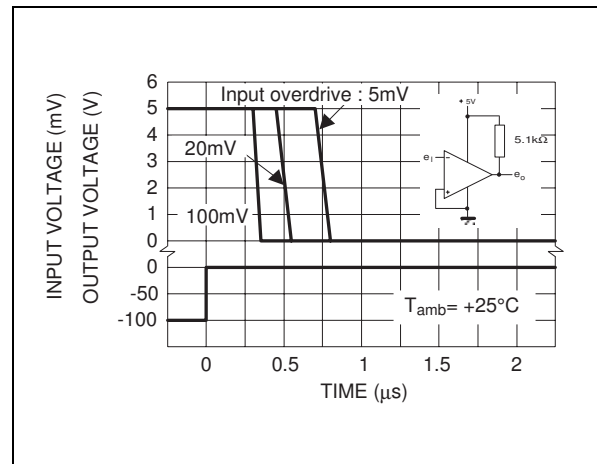

RESPONSE TIME FOR VARIOUS INPUT OVERDRIVES - POSITIVE TRANSITION

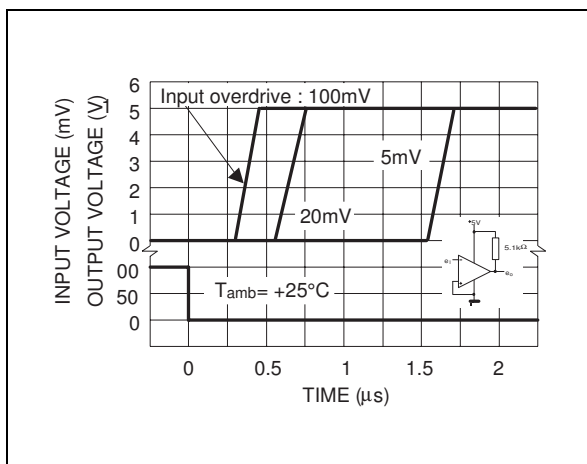

TYPICAL APPLICATIONS

BASIC COMPARATOR

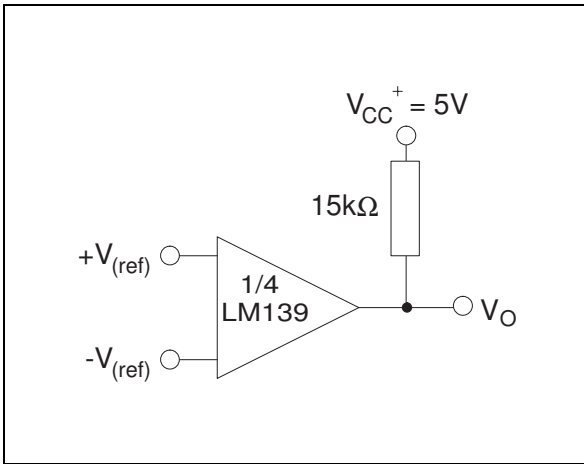

DRIVING CMOS

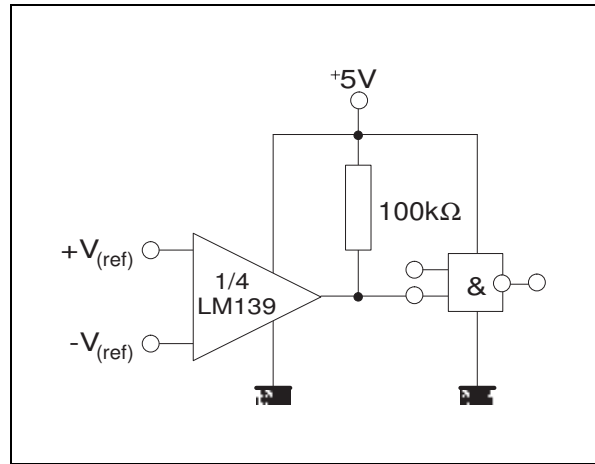

DRIVING TTL

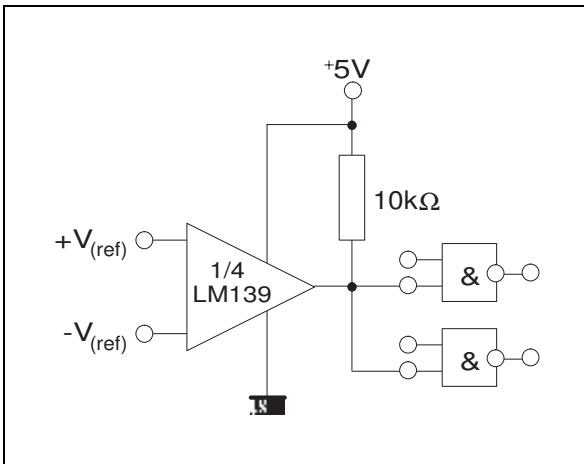

LOW FREQUENCY OP AMP

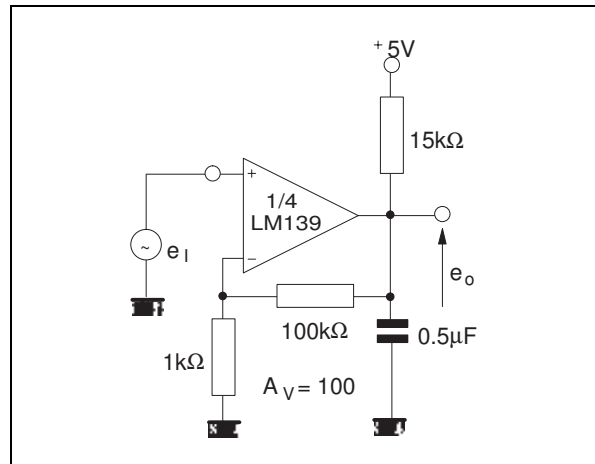

LOW FREQUENCY OP AMP

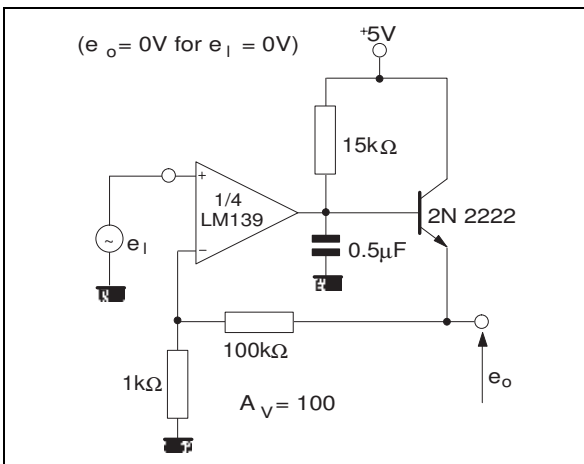

TRANSDUCER AMPLIFIER

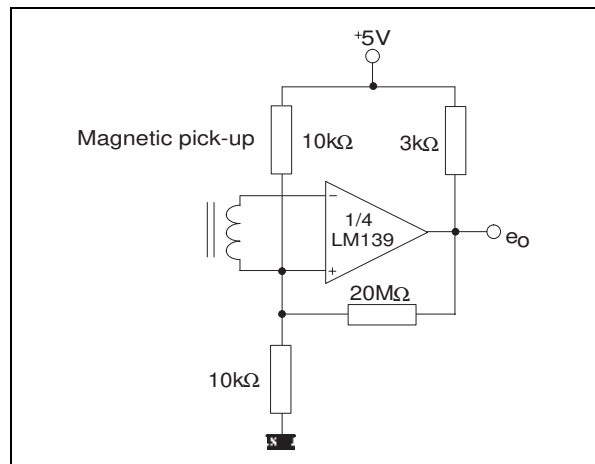

TYPICAL SINGLE (continued)

TIME DELAY GENERATOR

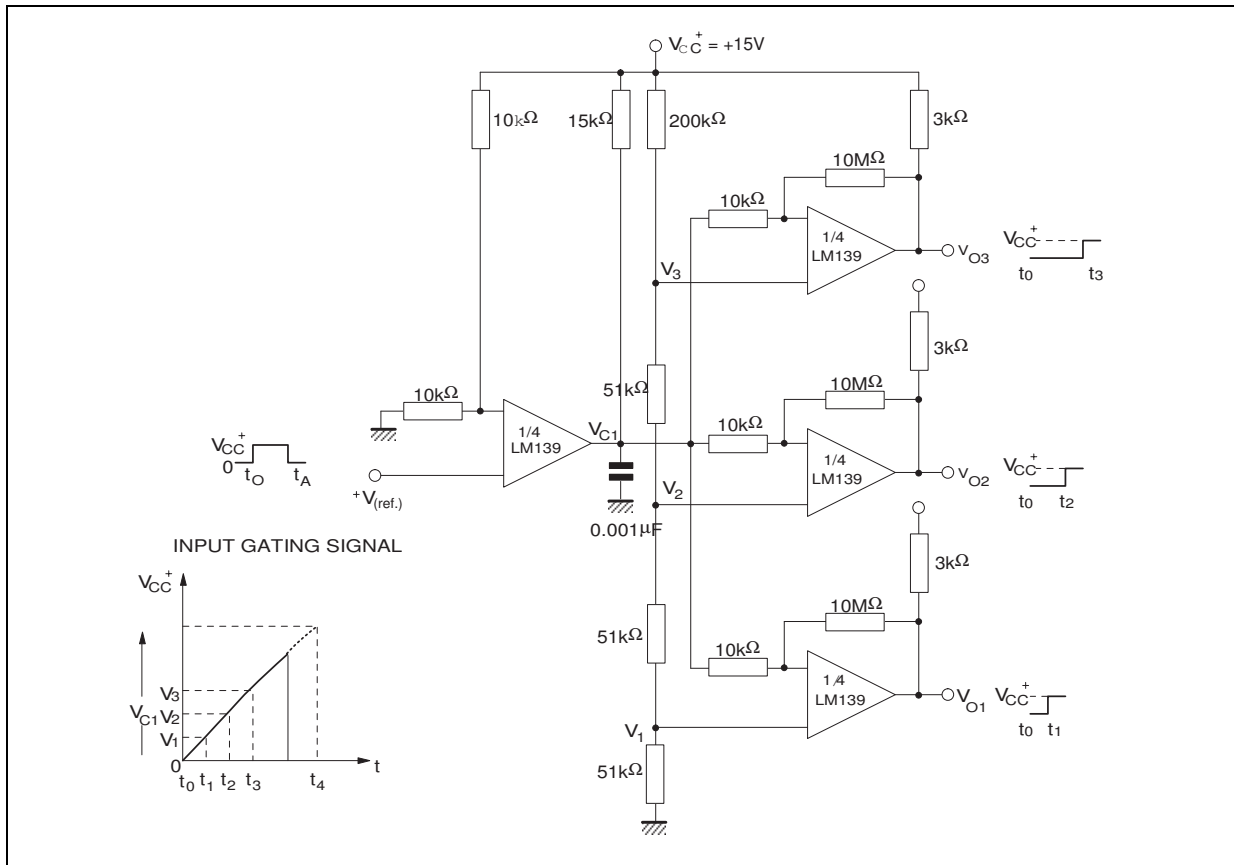

LOW FREQUENCY OP AMP WITH OFFSET ADJUST

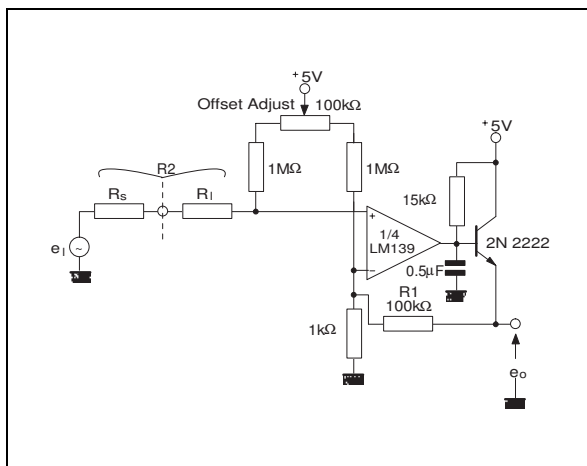

ZERO CROSSING DETECTOR (single power supply)

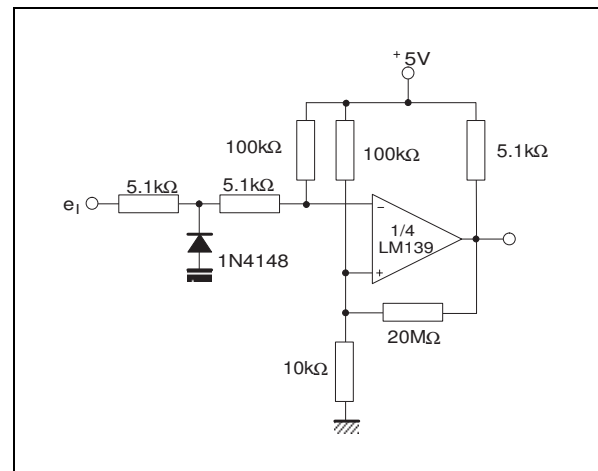

TYPICAL SINGLE (continued)

TWO-DECADE HIGH-FREQUENCY VCO

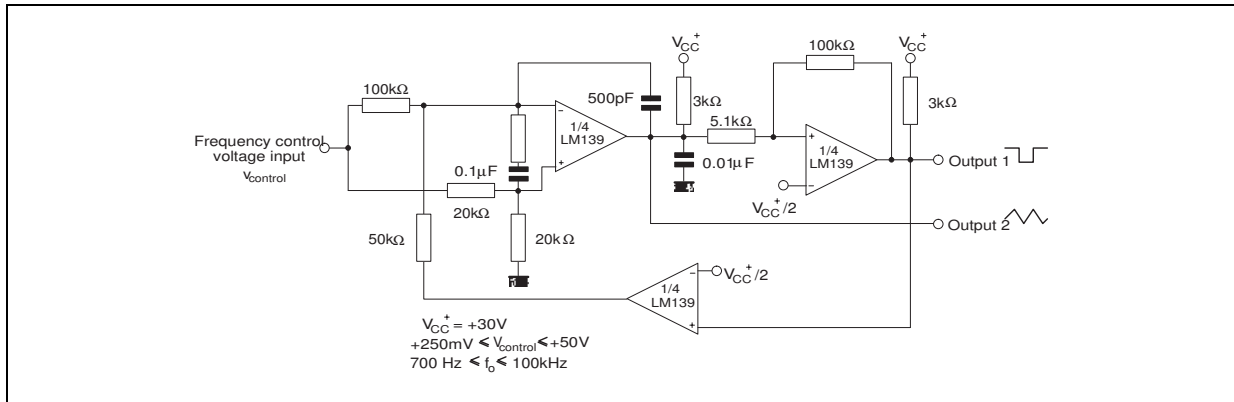

LIMIT COMPARATOR

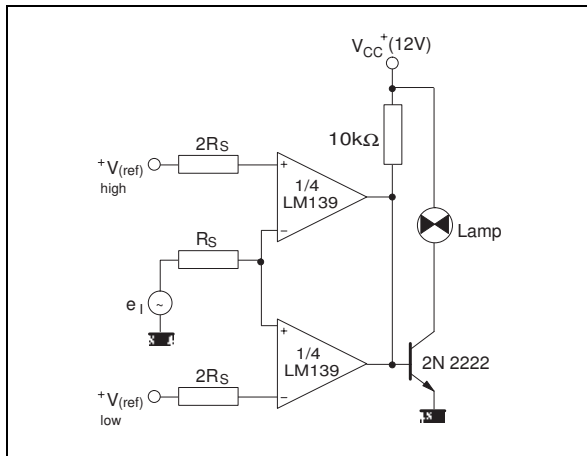

CRYSTAL CONTROLLED OSCILLATOR

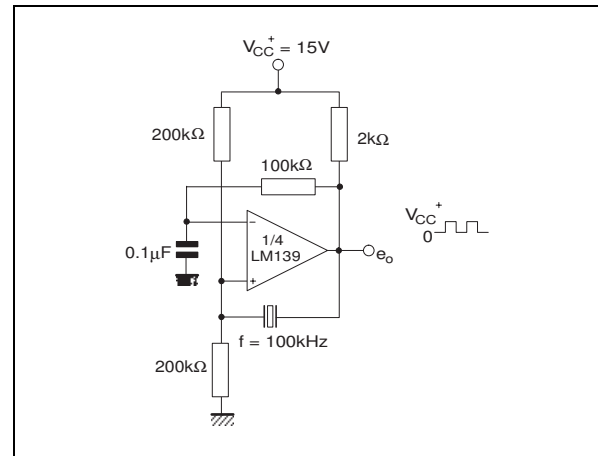

SPLIT-SUPPLY APPLICATIONS

ZERO CROSSING DETECTOR

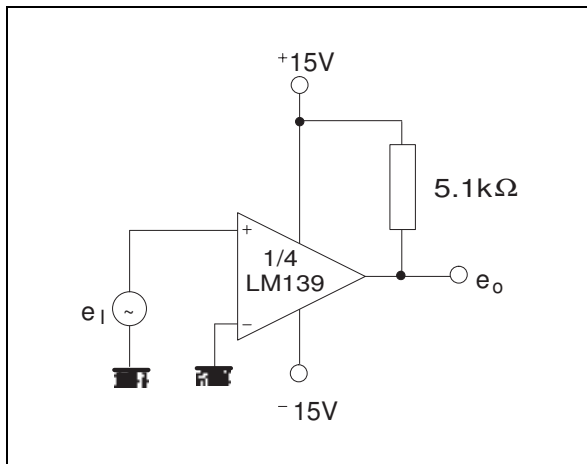

COMPARATOR WITH A NEGATIVE REFERENCE

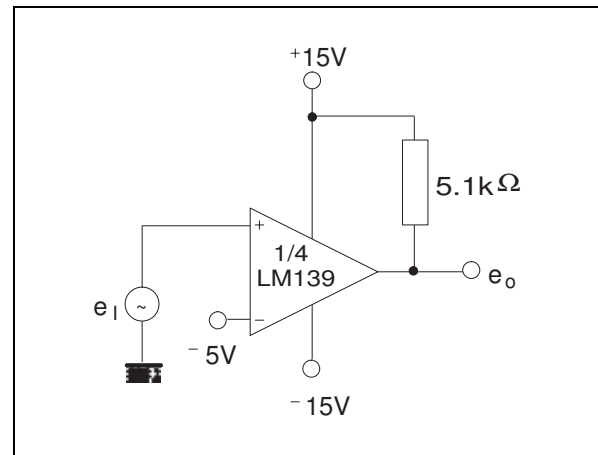

PACKAGE MECHANICAL DATA
14 PINS - PLASTIC DIP

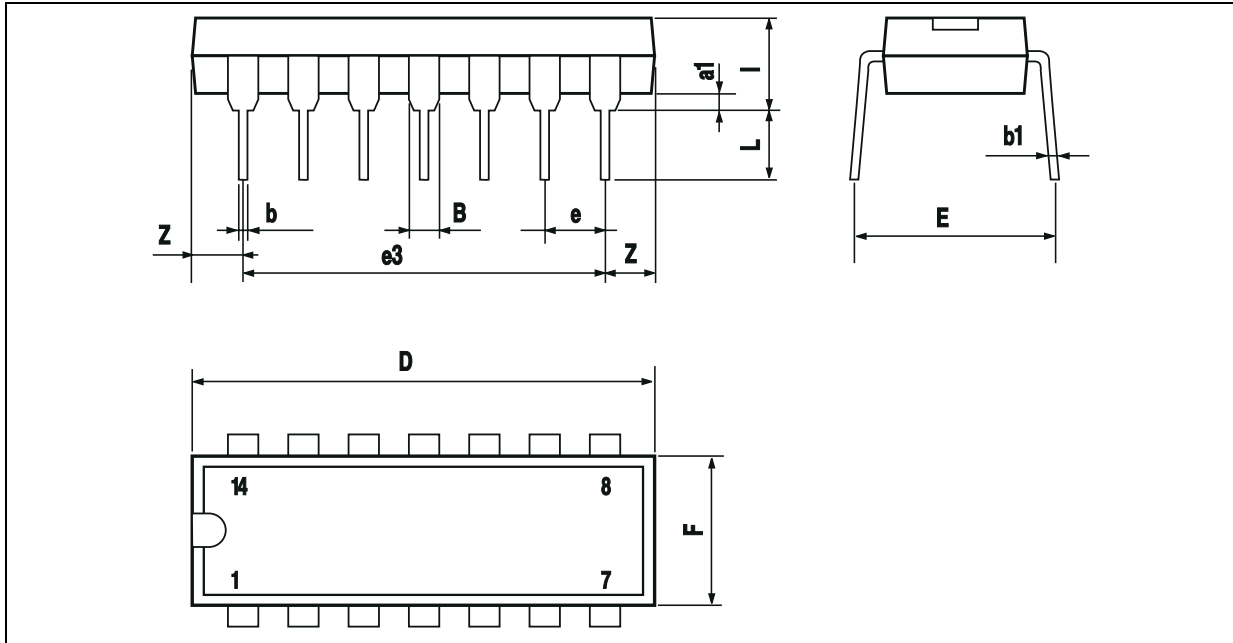

Dimensions	Millimeters			Inches		
	Min.	Typ.	Max.	Min.	Typ.	Max.
a1	0.51			0.020		
B	1.39		1.65	0.055		0.065
b		0.5			0.020	
b1		0.25			0.010	
D			20			0.787
E		8.5			0.335	
e		2.54			0.100	
e3		15.24			0.600	
F			7.1			0.280
i			5.1			0.201
L		3.3			0.130	
Z	1.27		2.54	0.050		0.100

PACKAGE MECHANICAL DATA
 14 PINS - PLASTIC MICROPACKAGE (SO)

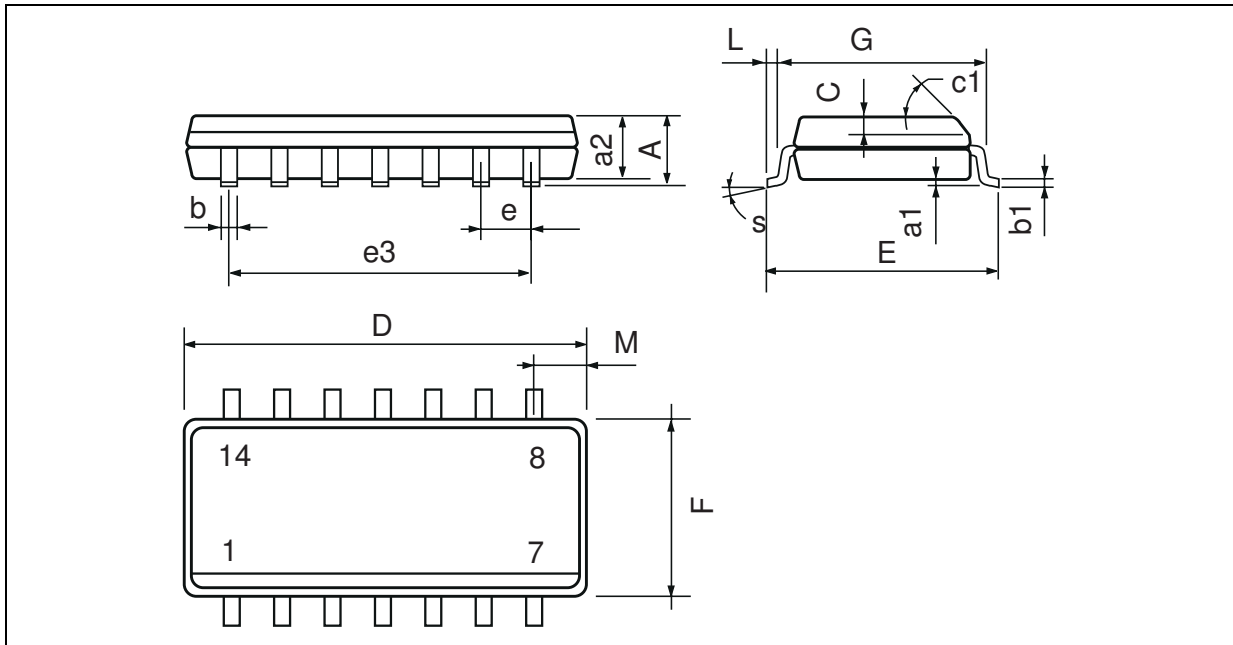

Dimensions	Millimeters			Inches		
	Min.	Typ.	Max.	Min.	Typ.	Max.
A			1.75			0.069
a1	0.1		0.2	0.004		0.008
a2			1.6			0.063
b	0.35		0.46	0.014		0.018
b1	0.19		0.25	0.007		0.010
C		0.5			0.020	
c1	45° (typ.)					
D (1)	8.55		8.75	0.336		0.344
E	5.8		6.2	0.228		0.244
e		1.27			0.050	
e3		7.62			0.300	
F (1)	3.8		4.0	0.150		0.157
G	4.6		5.3	0.181		0.208
L	0.5		1.27	0.020		0.050
M			0.68			0.027
S	8° (max.)					

Note : (1) D and F do not include mold flash or protrusions - Mold flash or protrusions shall not exceed 0.15mm (.066 inc) ONLY FOR DATA BOOK.

PACKAGE MECHANICAL DATA

14 PINS - THIN SHRINK SMALL OUTLINE PACKAGE

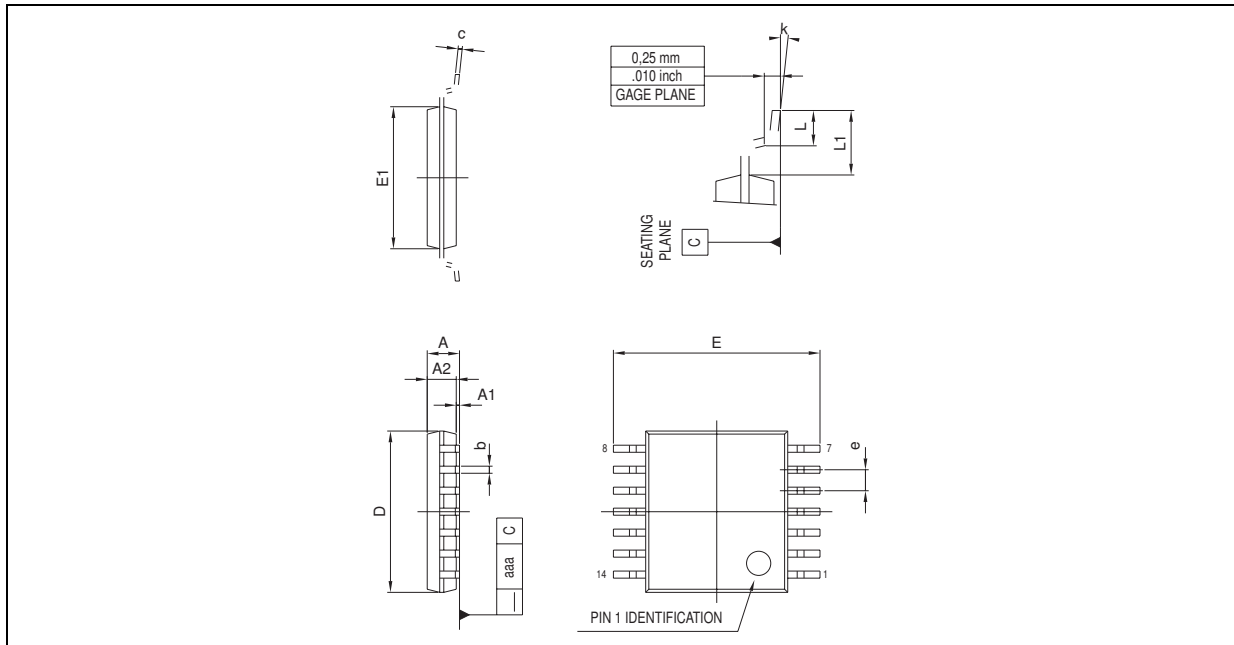

Dimensions	Millimeters			Inches		
	Min.	Typ.	Max.	Min.	Typ.	Max.
A			1.20			0.05
A1	0.05		0.15	0.01		0.006
A2	0.80	1.00	1.05	0.031	0.039	0.041
b	0.19		0.30	0.007		0.15
c	0.09		0.20	0.003		0.012
D	4.90	5.00	5.10	0.192	0.196	0.20
E		6.40			0.252	
E1	4.30	4.40	4.50	0.169	0.173	0.177
e		0.65			0.025	
k	0°		8°	0°		8°
L	0.450	0.600	0.750	0.018	0.024	0.030
L1		1.00			0.039	
aaa			0.100			0.004

Information furnished is believed to be accurate and reliable. However, STMicroelectronics assumes no responsibility for the consequences of use of such information nor for any infringement of patents or other rights of third parties which may result from its use. No license is granted by implication or otherwise under any patent or patent rights of STMicroelectronics. Specifications mentioned in this publication are subject to change without notice. This publication supersedes and replaces all information previously supplied. STMicroelectronics products are not authorized for use as critical components in life support devices or systems without express written approval of STMicroelectronics.

© The ST logo is a registered trademark of STMicroelectronics

© 2002 STMicroelectronics - Printed in Italy - All Rights Reserved
STMicroelectronics GROUP OF COMPANIES

Australia - Brazil - Canada - China - Finland - France - Germany - Hong Kong - India - Israel - Italy - Japan - Malaysia
Malta - Morocco - Singapore - Spain - Sweden - Switzerland - United Kingdom - United States

© <http://www.st.com>