

Features and benefits

- 12V to 40V operating range
- BVDSS > 60V
- On-chip “boost” voltage allows use of all N-channel drivers
- On-chip PWM oscillator
- PWM speed control via bottom drivers
- Forward and reverse control
- Selectable 60° or 120° sensor electrical phasing
- Undervoltage lockout
- Qualified for automotive applications

Ordering information

Part No.	Temperature Code	Package Code
MLX90401	K (-40°C to 125°C)	DF (300” SOIC24)

Application examples

- Handheld Battery powered applications:
 - Power tools (drills, screwdrivers, etc.)
- Electrical bicycles, wheelchairs, etc.
- Automotive applications:
 - Manual HVAC Blowers
 - Water and other pumps

1 Pin configuration

1	Supply Voltage	Cap Boost "A"	24
2	V _{REF} Out	Gate Top "A"	23
3	Hall "A" Input	Feedback "A"	22
4	Hall "B" Input	Cap Boost "B"	21
5	Hall "C" Input	Gate Top "B"	20
6	Fwd/Rev Input	Feedback "B"	19
7	Speed Adjust Input / Disable	Cap Boost "C"	18
8	Oscillator R/C	Gate Top "C"	17
9	/Brake Input	Feedback "C"	16
10	Analog Ground	Gate Bottom "A"	15
11	60°/120° Select Input	Gate Bottom "B"	14
12	Power Ground	Gate Bottom "C"	13

Figure 1: Pin configuration

2 General description

The MLX90401 is a three-phase brushless DC motor controller, designed to meet the needs of high volume, low cost motors with 60° or 120° electrical sensor phasing which do not require the expensive options needed for servo or other closed loop applications.

The use of CMOS technology offers dense logic as well as high voltage (60V) driver capabilities. The use of discrete low cost N-channel power FETs reduces overall system cost and the device provides all of the logic necessary to interface Hall-effect position sensors to N-channel power FETs. Upper N-channel power FETs require a gate drive in excess of the supply voltage V+, and with the device's on-chip “boost” voltage, the use of all N-Channel power FETs is allowed. Control inputs are provided for motor speed, forward or reverse direction, disable, and braking. 60° or 120° electrical sensor phasing can be set externally.

The device is offered in a 24 Lead Wide Body SOIC package (DF).

Table of content

1 Pin configuration	1
2 General description	1
3 Glossary of terms	3
4 Pin definitions and description.....	3
5 Absolute maximum ratings.....	4
6 MLX90401 electrical specifications	4
7 General description	5
7.1 Overview	5
7.2 Block diagram	6
7.3 Commutation decoding and output control logic.....	7
7.4 Oscillator	7
7.5 Disable	7
7.6 Pulse width modulation	8
7.7 Drive outputs	8
7.8 Undervoltage lockout	9
7.9 Logic table.....	9
8 Application information.....	10
8.1 Evaluation Board.....	10
8.2 Typical application.....	10
9 FAQ	11
9.1 Bootstrap capacitor selection.....	11
9.2 Motor Noise.....	11
10 Reliability Information	11
11 ESD Precautions	12
12 FAQ	12
13 Package Information.....	12
14 Disclaimer.....	13

3 Glossary of terms

FET	Field Effect Transistor
PWM	Pulse Width Modulation
Undervoltage	State in which the power supply voltage is lower than the operation range of the device.
Overcurrent	State in which the current flowing in a certain device (e.g. output driver, motor, etc.) exceeds a maximum defined level. This includes both overload and short-circuit currents.

4 Pin definitions and description

Pin	Symbol	Description
1	Supply voltage	External power supply voltage.
2	V _{REF} Out	Regulated reference voltage (12V) derived from V+. Used to power external components and Hall-effect sensors, and for boost voltage.
3-5	Hall "A", "B" and "C" Inputs	Hall IC open collect inputs. Pull-up resistance of 3.3k to 5V.
6	Fwd/Rev Input	The Forward/Reverse Input is used to change the direction of motor rotation. A logic high state selects forward direction; a logic low state selects reverse direction. Pull-up resistance of 3.3k to 5V.
7	Speed Adjust Input/Disable	Potentiometer input - adjusts the PWM duty cycle setting current, allowing a manual speed adjustment. Disable input can be used in combination with any type of switch (thermal, Hall, etc.). A logic low on this pin selects the disable function.
8	Oscillator R/C	The Oscillator frequency is set with the values selected for the timing components RRC and CRC.
9	/Brake Input	A logic high state at this input allows the motor to run, while a low state causes rapid deceleration. Pull-up resistance of 3.3k to 5V.
10	Analog ground	Ground pin for analog blocks.
11	60°/120° Select Input	A logic high state on this pin selects 60° sensor electrical phasing, a logic low state selects 120°. Pull-up resistance of 3.3k to 5V.
12	Power Ground	Ground pin for digital and output drivers.
13-15	Gate Bottom "A", "B" and "C"	Three push-pull drivers for direct drive of bottom power switch transistors.
16, 19, 22	Feedback "A", "B" and "C"	Negative supply of the top drive circuitry. It is the connection for the negative side of the bootstrap capacitor, the top power FET Source, the bottom power FET Drain, and the Phase C output.
17, 20, 23	Gate Top "A", "B" and "C"	Three push-pull drivers for direct drive of top power switch transistors.
18, 22, 24	Cap Boost "A", "B" and "C"	Positive supply of the top drive circuitry. The boost capacitor is connected between this pin and Feedback.

Table 1: Pin definitions and description

5 Absolute maximum ratings

Parameter	Absolute maximum value
Supply Voltage, V_{DD} (operating)	-0.3 to 45V
Output Voltage on pins Gate & Cap Boost	60V
Voltage on Pins 17,18,20,21,23,24	-0.3 to 60V
Power Dissipation, P_D	500mW
Operating Temperature Range, T_A	-40 to 125°C
Storage Temperature Range, T_S	-40 to 125°C

Table 2: Absolute maximum ratings

6 MLX90401 electrical specifications

DC Operating Parameters $T_A = -40\text{ }^\circ\text{C}$ to $125\text{ }^\circ\text{C}$

Parameter.	Symbol	Test Conditions	Min	Typ	Max	Units
Supply voltage	V_{DD}	Operating	8	12-24	44	V
Supply current	I_{DD}	Operating		20	35	mA
Voltage reference						
Output voltage	V_{REF}		8	12	15	V
Output current	I_{REF}				10	mA
Undervoltage						
Undervoltage	V_{UV}	Operating		8		V
Oscillator						
Oscillator frequency	f_{OSC}	Operating, $R_{OSC}=10\text{k}\Omega$, $C_{OSC}=5\text{nF}$	22	25	28	kHz
Logic inputs (Pins 2-6, 9, 11)						
High state	V_{IH}		3.5			V
Low state	V_{IL}				1.5	V
High state input current	I_{IH}				1.0	mA
Low state input current	I_{IL}				2.0	mA
Disable input (Pin 7)						
100% PWM state ¹	$V_{100\%PWM}$			64.3		%Vref
0% PWM ¹	$V_{0\%PWM}$			35.7		%Vref
Disable ¹	$V_{DISABLE}$			16		%Vref
High state input current	I_{IHDIS}				1.0	mA
Low state input current	I_{ILDIS}				1.0	mA
Debouncing						
Debounce time (60°/120° Select, Fwd/Rev) ²	t_{delay1}		18	25	35	ms
Debounce time (/Brake) ²	t_{delay2}		2.0	3.2	4.4	ms
Delay after start-up ³	t_{delay3}		18.6	25.6	35.6	ms
Charge pumps						
Output current	I_{OCP}				100	uA

¹ Input levels of the DISABLE pin are defined internally by a resistor tree.

² t_{delay1} and t_{delay2} depend on f_{osc} and timing of the signals to be debounced. 60°/120° Select and Fwd/Rev are debounced using a clock with a frequency of $256 \cdot f_{osc}$. /Brake is debounced using a clock with a frequency of $32 \cdot f_{osc}$. Debouncing takes between 2 and 3 clock cycles. Typical example for, say 60°/120° Select: $2.5 \cdot 256 \cdot 1 / f_{osc} = 2.5 \cdot 256 \cdot 1 / 25\text{kHz} = 25.6\text{ ms}$.

³ t_{delay3} depends on f_{osc} . Precautions are taken that t_{delay3} is *always* larger than t_{delay1} , so that there are only output signals when the chip is in the correct state.

Drivers						
Top output on resistance	R_{ONT}	$I_{LOAD} = 50mA$			32	Ohm
Bottom output on resistance	R_{ONB}	$I_{LOAD} = 50mA$			32	Ohm
Rise time	t_r				150	ns
Fall time	t_f				150	ns
Turn-on propagation delay	t_{don}				300	ns
Turn-off propagation delay	t_{doff}				300	ns
Top drivers						
Leakage current	I_{OFF}	$V_{OUT} = 60V$			-10	μA

Table 3: MLX90401 electrical specifications

7 General description

7.1 Overview

The MLX90401 contains all functions for controlling three-phase brushless DC motors in open loop applications.

The MLX90401 supports following control functions:

- speed control
- forward or reverse rotation
- braking
- disable

The chip contains:

- a rotor position decoder for proper commutation sequencing
- a voltage reference that supplies power for the sensors
- a pulse width modulator (PWM) based on a frequency programmable sawtooth oscillator
- three top and three bottom drivers

Using a bootstrap/charge pump combination, the MLX90401 also generates a boost voltage to drive the top power FET. In this way the application only uses N-channel power FETS, to reduce overall system cost.

The MLX90401 provides commutation from Hall-effect sensors, and can be configured for motors with 60° or 120° sensor electrical phasing, by means of a select pin.

Undervoltage lockout is provided.

7.2 Block diagram

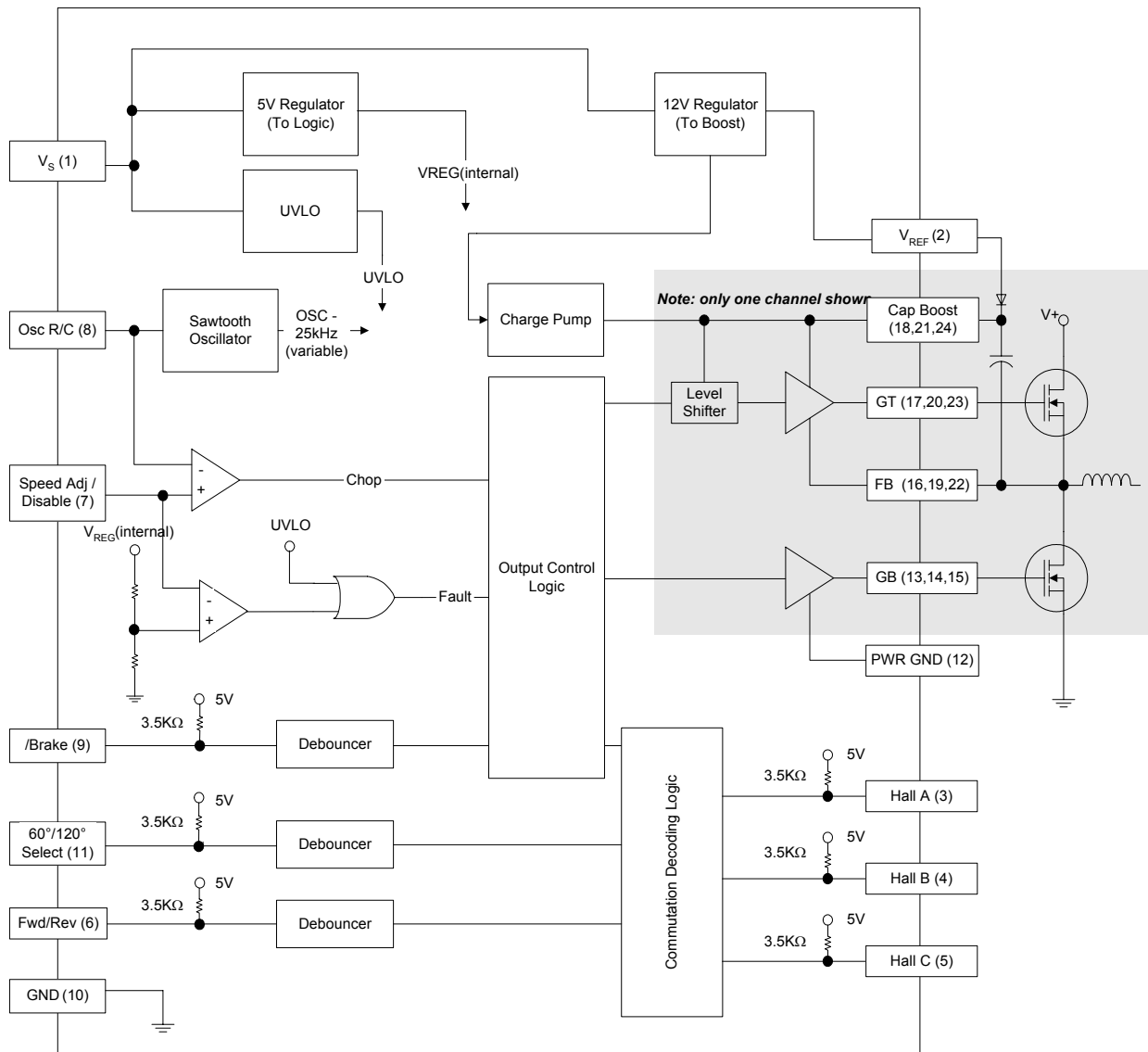

Figure 2 : Block diagram

7.3 Commutation decoding and output control logic

An internal digital circuit converts the signals from the Hall-effect position sensors into the proper sequencing of top and bottom drive outputs.

60° or 120° sensor electrical phasing can be selected by an external pin (60°/120° Select, pin 11).

The Forward/Reverse input (pin 6) is used to change the direction of motor rotation.

If the /Brake input (pin 9) is pulled low, bottom drivers are turned on, while top drivers are turned off, thus braking the motor.

These six inputs all have internal pull-up resistors (3.3kΩ to 5V).

Inputs 60°/120° Select, Fwd/Rev and /Brake are debounced to make sure that the device doesn't enter the wrong state, due to noise and/or spikes.

The fact that these signals are debounced, also means that there is a delay in these signals. Whenever one of the external signals that are debounced is changed, it takes time till the outputs change accordingly (ca. 25ms for the 60°/120° Select and Fwd/Rev inputs, ca. 3ms for /Brake).

After start-up, the outputs are disabled for a given time, in order to provide for the time necessary for the debouncing circuits on 60°/120° Select and Fwd/Rev to settle and output the correct signal.

(/Brake is debounced with a shorter time so settles a lot sooner.)

7.4 Oscillator

The frequency of the internal sawtooth oscillator is set by the values selected for timing components R_{OSC} and C_{OSC} (see Figure 4 : Typical application). Capacitor C_{OSC} is charged from the Reference Output (Pin 2) through Resistor R_{OSC} and discharged by an internal discharge transistor. The ratio of the ramp peak and valley voltages referred to the Reference Output voltage are typically 0.65V and 0.3V respectively. To provide a good compromise between audible noise and output switching efficiency, an oscillator frequency in the range of 20 to 30 kHz is recommended.

7.5 Disable

Pin 7, Speed Adjust Input/Disable, is to be connected to an external potentiometer, used to set motor speed.

The input can also be used as a Disable input, turning off all output drivers. This Disable input can be used in many ways. A thermal switch could be used to provide thermal protection. Or a Hall switch could be used to provide protection against overcurrent, etc.

Disable has a higher priority than /Brake. If for instance Disable is active, braking will not have any effect. If /Brake is active at the moment that Disable is made active, all braking will be stopped.

7.6 Pulse width modulation

The use of pulse width modulation (PWM) provides an energy efficient method of controlling the motor speed by varying the average voltage applied to each stator winding during the commutation sequence. As C_{OSC} discharges, the oscillator allows conduction of the top and bottom drive outputs. The PWM comparator terminates the bottom drive output conduction when the positive-going ramp of C_{OSC} becomes greater than the Speed Adjust Input. In order to minimize dissipation in the internal diodes of the external top switch transistors, due to free-wheeling currents, the PWM acts also on the top FET, by turning it on when the corresponding bottom FET is off. The pulse width modulator timing diagram is shown below. (Braking of the motor does not depend on the PWM setting. It is always done at 100%.)

PWM Timing Diagram (note 1)

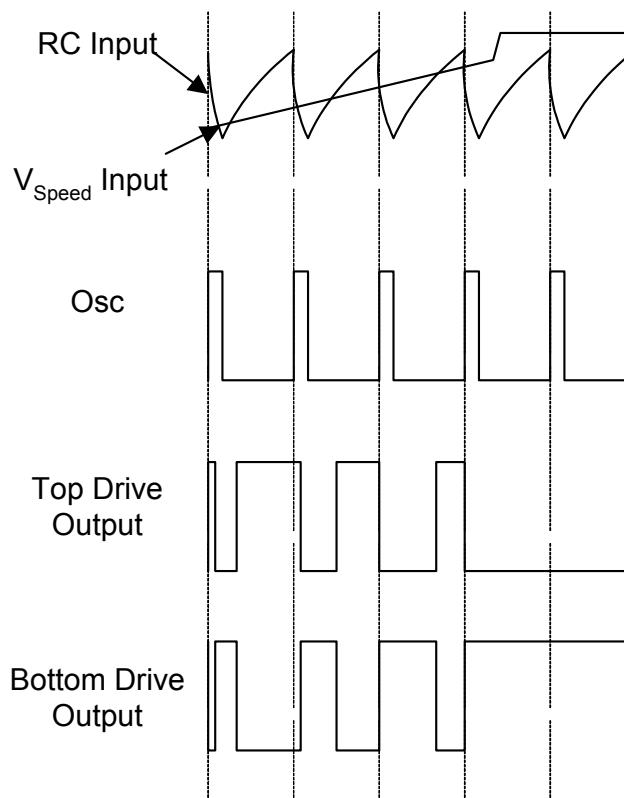

Note 1. Top and Bottom Drive Output Diagrams assume commutation logic gives 1 for bottom switch and 0 for top switch. In case the commutation logic gives 0 for bottom switch and 1 for top switch, the PWM does not act on them.

Figure 3: PWM timing diagram

7.7 Drive outputs

The bottom drivers consist of a push-pull driver between the 12V reference voltage and ground.

The top drivers use an improved push-pull architecture to guarantee proper drive of the top FETs. Because the top driver utilizes a bootstrap/charge pump combination, use of only N-channel power FETs for the three-phase bridge is possible. This leads to a reduced system cost.

Internal charge pumps precharge the boost capacitors to ensure full drive of upper power FETs at start-up. During normal operation, boost is maintained with an external diode and capacitor. The charge pumps compensate for potential leakage currents, in order to ensure that the upper power FETs are driven properly at all time.

7.8 Undervoltage lockout

Should the voltage level on V_{DD} drop below the undervoltage level, all gate drives will be turned off until the undervoltage condition disappears, to prevent improper drive of the power FETs.

7.9 Logic table

Following table shows the output state in function of the inputs. It summarizes the different functions of the MLX90401. SA = Hall Sensor input A, ...

Motor position	Inputs									Outputs								
	Sensor Electrical Phasing						Fwd/Rev	/Brake	/Disable	Top Drive			Bottom Drive			Motor phases		
	60°			120°						TA	TB	TC	BA	BB	BC	PA	PB	PC
	SA	SB	SC	SA	SB	SC												
0°	0	0	0	1	0	1	1	1	1	1	0	0	0	1	0	^	v	-
60°	1	0	0	1	0	0	1	1	1	1	0	0	0	0	1	^	-	v
120°	1	1	0	1	1	0	1	1	1	0	1	0	0	0	1	-	^	v
180°	1	1	1	0	1	0	1	1	1	0	1	0	1	0	0	v	^	-
240°	0	1	1	0	1	1	1	1	1	0	0	1	1	0	0	v	-	^
300°	0	0	1	0	0	1	1	1	1	0	0	1	0	1	0	-	v	^
0°	0	0	0	1	0	1	0	1	1	0	1	0	1	0	0	v	^	-
300°	0	0	1	0	0	1	0	1	1	0	1	0	0	0	1	-	^	v
240°	0	1	1	0	1	1	0	1	1	1	0	0	0	0	1	^	-	v
180°	1	1	1	0	1	0	0	1	1	1	0	0	0	1	0	^	v	-
120°	1	1	0	1	1	0	0	1	1	0	0	1	0	1	0	-	v	^
60°	1	0	0	1	0	0	0	1	1	0	0	1	1	0	0	v	-	^
	x	x	x	x	x	x	x	0	1	0	0	0	1	1	1	v	v	v
	x	x	x	x	x	x	x	x	0	0	0	0	0	0	0	-	-	-

Table 4 : Logic table

The phases mentioned in the table are electrical phases as they are generated by the Hall sensors. The difference between a 60 degree motor and a 120 degree motor is shown in the graph below. By manually turning the motor these outputs can easily be found on an oscilloscope.

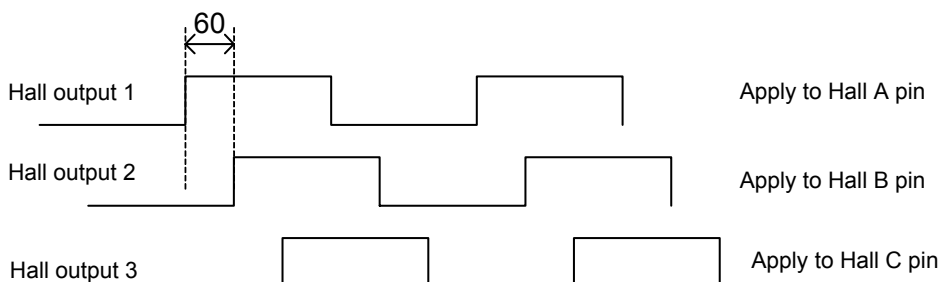
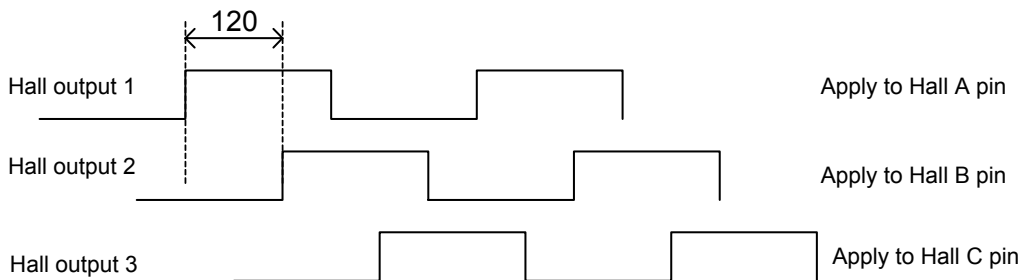

8 Application information

8.1 Evaluation Board

An Evaluation Board for the MLX90401 called EVB90401 is available. The accompanying Application Note describes the Board, and gives extra information concerning the use of the MLX90401 in real-life applications.

Consult our website www.melexis.com for more information.

8.2 Typical application

Shown below is a typical application of the MLX90401 that could be used for battery-operated power tools. A manual HVAC blower schematic looks similar, but zener DZ1 should be chosen at for instance 18V.

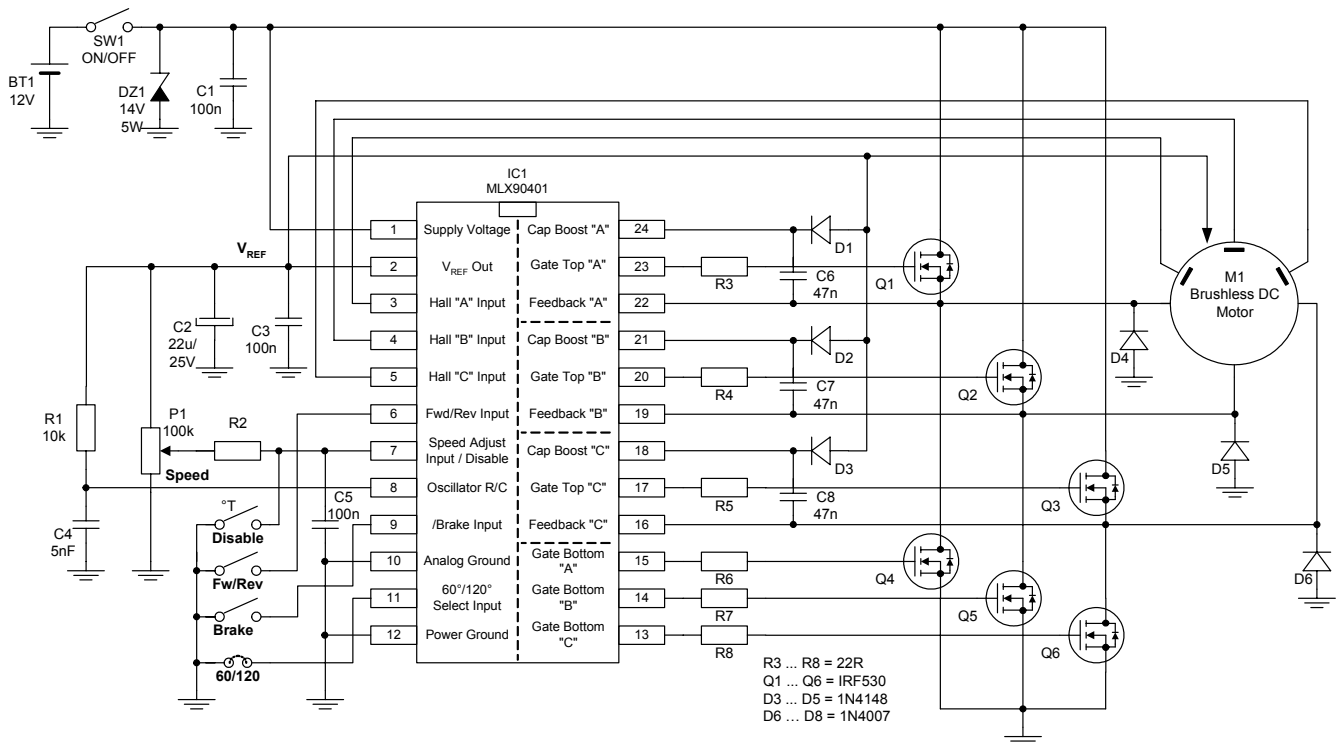

Figure 4 : Typical application

This example system is powered by a 12V battery.

- DZ1 is a high power zener diode to clamp the battery line when the system is switched off using SW1: motor M1 could generate a voltage on the power line after shut down, causing the power line to rise and potentially exceed the maximum rating of the MLX90401. DZ1 prevents this. Its voltage specification should be chosen a few volt above the maximum rating of the power supply, but obviously not higher than the absolute maximum rating of the MLX90401. It should be a high power device since it has to absorb a lot of energy in a short time.

Other components:

- C1 decouples the power line and should be placed as close as possible to the MLX90401.
- R1/C4 are the external RC for the oscillator.
- The VREF line is decoupled with C2 and C3. VREF powers the Hall effect sensors and the speed potentiometer P1. This signal is filtered using R2/C5 to prevent noise of entering the PWM circuit.
- A thermal switch is connected to the Disable input to protect the system from overheating: if the temperature exceeds the thermal switch threshold, it switches on, and disables the motor.

- A Forward/Reverse switch is present; the Brake switch could be omitted depending on the application.
- A jumper or fixed PCB track selects the type of motor (60/120 degrees electrical sensor spacing).
- D1-3 and C6-8 are the bootstrap diode and capacitor.
- Q1-6 are the 6 N-channel power FETs.
- R3-8 smoothen the rise and fall times of the gate signals to reduce EMC emissions.
- D4-6 are freewheel diodes.

9 FAQ

9.1 Bootstrap capacitor selection

When the top side is turned on charge is transferred from the bootstrap capacitor to the gate capacitance of the N-channel power FET. The bootstrap capacitor value is chosen in function of the gate charge of the N-channel power FETs used.

The charge on the bootstrap capacitor should be at least 20 times greater than the gate charge of the power FET.

E.g. for the IRF530 N-channel power FET the total gate charge is specified as 26 nC. Therefore:

$$C_{boot} = 20 \times Q_{gate} / V_{gate} = 20 \times Q_{gate} / V_{REF} = 20 \times 26 \text{ nC} / 12 \text{ V} = 43 \text{ nF}.$$

A value of 47 nF is chosen.

The maximum voltage drop due to the charge transfer at turn-on is:

$$dV_{gate} = dq / C_{boot} = Q_{gate} / C_{boot} = 26 \text{ nC} / 47 \text{ nF} = 553 \text{ mV}.$$

Bootstrap capacitors up to 100nF can be applied.

9.2 Motor Noise

The MLX90401 defines its switching sequence based on the Hall input sequence and the state of the 60°/120° Select Input.

A 120° electrical sensor phasing motor operated with a 60° setting will most likely function, but will generate clearly audible noise. Vice versa a 60° motor will generate noise when operated with a 120° setting. Changing the setting of 60°/120° Select Input should remove the noise.

See also paragraph 7.9 Logic table for an explanation how to find out if a motor has 60° or 120° electrical sensor phasing, and how to connect the phases to the MLX90401 Hall sensor inputs.

10 Reliability Information

This Melexis device is classified and qualified regarding soldering technology, solderability and moisture sensitivity level, as defined in this specification, according to following test methods:

- IPC/JEDEC J-STD-020
Moisture/Reflow Sensitivity Classification For Nonhermetic Solid State Surface Mount Devices
(Classification reflow profiles according to table 5-2)
- EIA/JEDEC JESD22-A113
Preconditioning of Nonhermetic Surface Mount Devices Prior to Reliability Testing
(Reflow profiles according to table 2)
- CECC00802
Standard Method For The Specification of Surface Mounting Components (SMDs) of Assessed Quality
- EIA/JEDEC JESD22-B106
Resistance to soldering temperature for through-hole mounted devices

- EN60749-15
Resistance to soldering temperature for through-hole mounted devices
- MIL 883 Method 2003 / EIA/JEDEC JESD22-B102
Solderability

For all soldering technologies deviating from above mentioned standard conditions (regarding peak temperature, temperature gradient, temperature profile etc) additional classification and qualification tests have to be agreed upon with Melexis.

The application of Wave Soldering for SMD's is allowed only after consulting Melexis regarding assurance of adhesive strength between device and board.

Based on Melexis commitment to environmental responsibility, European legislation (Directive on the Restriction of the Use of Certain Hazardous substances, RoHS) and customer requests, Melexis has installed a Roadmap to qualify their package families for lead free processes also. Various lead free generic qualifications are running, current results on request.

For more information on manufacturability/solderability see the quality page on our website:
<http://www.melexis.com/html/pdf/MLXleadfree-statement.pdf>.

11 ESD Precautions

Electronic semiconductor products are sensitive to Electro Static Discharge (ESD). Always observe Electro Static Discharge control procedures whenever handling semiconductor products.

12 FAQ

Consult the Application Note concerning the EVB90401 MLX90401 Evaluation Board for more information. It can be obtained from www.melexis.com.

13 Package Information

The MLX90401 will be assembled in a plastic wide body SOIC24 package.

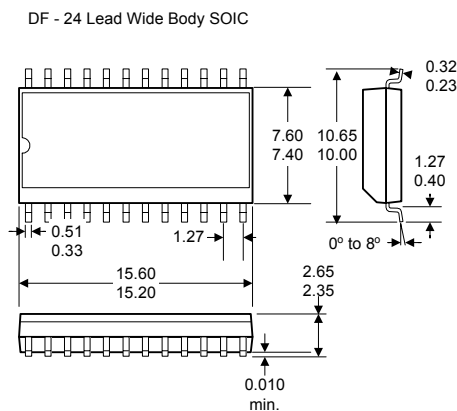

All dimensions in millimeters

Figure 5: Package information

14 Disclaimer

Devices sold by Melexis are covered by the warranty and patent indemnification provisions appearing in its Term of Sale. Melexis makes no warranty, express, statutory, implied, or by description regarding the information set forth herein or regarding the freedom of the described devices from patent infringement. Melexis reserves the right to change specifications and prices at any time and without notice. Therefore, prior to designing this product into a system, it is necessary to check with Melexis for current information. This product is intended for use in normal commercial applications. Applications requiring extended temperature range, unusual environmental requirements, or high reliability applications, such as military, medical life-support or life-sustaining equipment are specifically not recommended without additional processing by Melexis for each application.

The information furnished by Melexis is believed to be correct and accurate. However, Melexis shall not be liable to recipient or any third party for any damages, including but not limited to personal injury, property damage, loss of profits, loss of use, interrupt of business or indirect, special incidental or consequential damages, of any kind, in connection with or arising out of the furnishing, performance or use of the technical data herein. No obligation or liability to recipient or any third party shall arise or flow out of Melexis' rendering of technical or other services.

© 2002 Melexis NV. All rights reserved.

For the latest version of this document, go to our website at
www.melexis.com

Or for additional information contact Melexis Direct:

Europe and Japan:

Phone: +32 1367 0495

E-mail: sales_europe@melexis.com

All other locations:

Phone: +1 603 223 2362

E-mail: sales_usa@melexis.com

ISO/TS 16949 and ISO14001 Certified