

**General Safety Instructions:**

READ SAFETY INSTRUCTIONS

**Servicing:**

These products are not customer serviceable TDK-Lambda UK LTD and their authorised agents only are permitted to carry out repairs.

**Critical Components:**

These products are not authorised for use as critical components in nuclear control systems, life support systems or equipment for use in hazardous environments without the express written approval of the Managing Director of TDK-Lambda EMEA.

**Product Usage:**

These products are designed for use within a host equipment which restricts access to authorised competent personnel.

This product is a component power supply and is only to be installed by qualified persons within other equipment and must be not operated as a stand alone product.

This product is for sale to business to business customers and can be obtained via distribution channels.

It is not intended for sale to end users.

This product is a component power supply and does not fall within the scope of the EMC directive. Compliance with the EMC directive must be considered in the final installation. Please contact your local TDK-Lambda office.

**Environmental:**

These products are IPX0, and therefore chemicals/solvents, cleaning agents and other liquids must not be used.

**Environment:**

This power supply is a switch mode power supply for use in applications within a Pollution Degree 2, overvoltage category II environment. Material Group IIIb PCB's are used within it.

**Output Loading:**

The output power taken from the power supply must not exceed the rating stated on the power supply label, except as stated in the product limitations in this handbook.

**Input Parameters:**

This product must be operated within the input parameters stated in the product limitations in this handbook.

**End of Life Disposal:**

The unit contains components that require special disposal. Make sure that the unit is properly disposed of at the end of its service life and in accordance with local regulations.



RISK OF ELECTRIC SHOCK

**High Voltage Warning:**

Dangerous voltages are present within the power supply. The professional installer must protect service personnel from inadvertent contact with these dangerous voltages in the end equipment.

**WARNING:** When installed in a Class 1 end equipment, this product must be reliably earthed and professionally installed.

The (+) or (-) output(s) can be earthed or left floating.

The unit cover(s)/chassis (where applicable) must not be made user accessible.

The mains input connector is not acceptable for use as field wiring terminals.

For encased products, do not use mounting screws, which penetrate the unit more than; See drawings.

Internal fuses protect the unit and must not be replaced by the user. In case of internal defect, the unit must be returned to TDK-Lambda UK LTD or one of their authorised agents.

A suitable mechanical, electrical and fire enclosure must be provided by the end use equipment for mechanical, electric shock and fire hazard protection.

**Energy Hazards:**

LS200-7.5; LS200-12; LS200-15; LS200-18; LS200-24; LS200-28; LS200-36; LS200-40; LS200-48; LS200-56.

The main output of this product is capable of providing hazardous energy (240VA). Final equipment manufacturers must provide protection to service personnel against inadvertent contact with the output terminals.

The unit cover/chassis, where applicable, is designed to protect skilled personnel from hazards. They must not be used as part of the external covers of any equipment where they may be accessible to operators, since under full load conditions, part or parts of the unit chassis may reach temperatures in excess of those considered safe for operator access.

**Allgemeine Sicherheitsvorschriften:**

LESEN SIE DIE SICHERHEITSVORSCHRIFTEN

**Wartung:**

Diese Produkte können nicht durch den Kunden gewartet werden. Nur TDK-Lambda UK LTD. und deren zugelassene Vertriebshändler sind zur Durchführung von Reparaturen berechtigt.

**Kritische Komponenten:**

Diese Produkte sind nicht für die Verwendung als kritische Komponenten in nuklearen Kontrollsystemen, Lebenserhaltungssystemen oder Geräten in gefährlichen Umgebungen geeignet, sofern dies nicht ausdrücklich und in Schriftform durch den Geschäftsführer von TDK-Lambda EMEA genehmigt wurde.

**Produktverwendung:**

Diese Produkte sind zur Verwendung innerhalb von Host-Anlagen gedacht, die einen auf das Fachpersonal beschränkten Zugang haben.

Dieses Produkt ist eine Stromversorgungs-Komponente und sie darf nur von qualifiziertem Personal in andere Geräte eingebaut werden und sie darf NICHT als eigenständiges ("Stand-Alone") Gerät betrieben werden.

Dieses Produkt ist für den Verkauf an Geschäftskunden entwickelt worden und es kann über Distributionskanäle bezogen werden.

Es ist NICHT für den Verkauf an Endkunden gedacht und konzipiert.

Dieses Produkt ist eine Stromversorgungsbaugruppe und sie fällt NICHT in den Bereich der EMV Direktive.

Die Konformität mit der EMV Richtlinie muss in der finalen Gesamtinstallation betrachtet werden.

Bitte kontaktieren Sie Ihr regionales TDK-Lambda Vertriebsbüro im Falle von Rückfragen.

**Umwelt:**

Diese Produkte sind IPX0, aus diesem Grund dürfen keine Chemikalien/Lösungsmittel, Reinigungsmittel und andere Flüssigkeiten verwendet werden.

**Umgebung:**

Dieses Netzteil ist ein Schaltnetzteil zur Verwendung in einer Umgebung mit einem Verschmutzungsgrad 2, Überspannungskategorie II. Materialgruppe IIIb mit darin verwendeten PCBs.

**Ausgangsstrom:**

Der Ausgangsstrom des Netzteiles darf die Leistung, die auf dem Label des Netzteiles vermerkt ist, nur dann überschreiten, wenn dies in den Produktgrenzen dieses Handbuches ausgezeichnet ist.

**Eingangsparameter:**

Dieses Produkt muss innerhalb der Eingangsparameter, die in den Produktgrenzen dieses Handbuches angegeben sind, betrieben werden.

**Entsorgung am Ende der Betriebszeit:**

Das Gerät enthält Komponenten die unter Sondermüll fallen. Das Gerät muss am Ende der Betriebszeit ordnungsgemäß und in Übereinstimmung mit den regionalen Bestimmungen entsorgt werden.

**GEFAHR DURCH ELEKTRISCHEN SCHLAG****Hochspannungswarnung:**

Innerhalb des Netzteiles gibt es gefährliche Spannungen. Der Elektroinstallateur muss das Wartungspersonal vor versehentlichem Kontakt mit den gefährlichen Spannungen im Endgerät schützen.

**WARNUNG!** Falls Sie unser Netzgerät in eine Anwendung mit Schutzklasse 1 eingebaut haben, stellen Sie sicher, dass es fachgerecht installiert und zuverlässig geerdet ist.

Die (+) oder (-) Ausgänge können geerdet werden oder unangeschlossen bleiben.

Die Abdeckung des Gerätes/das Gehäuse darf für den Benutzer nicht zugänglich sein.

Der Haupteingangsanschluss ist nicht für die Verwendung als Feldverdrahtungsanschluss geeignet.

Für ummantelt Produkte, verwenden Sie keine Schrauben, die das Gerät mehr als durchdringen; siehe Zeichnung. Eine interne Sicherung schützt das Gerät und darf durch den Benutzer nicht ausgetauscht werden. Im Fall von internen Defekten muss das Gerät an TDK-Lambda UK LTD oder einen der autorisierten Vertriebshändler zurückgeschickt werden.

Ein geeignetes mechanisches, elektrisches und brandgeschütztes Gehäuse muss als Schutz vor der Gefahr von mechanischen Risiken, Stromschlägen und Brandschutz in dem Endgerät vorgesehen werden.

Gefahren durch elektrische Energie:

LS200-7.5; LS200-12; LS200-15; LS200-18; LS200-24; LS200-28; LS200-36; LS200-40; LS200-48; LS200-56.

Von bestimmten Modulen kann je nach Einstellung der Ausgangsspannung gefährliche elektrische Energie ausgehen (240 VA). Die Endgerätehersteller müssen einen Schutz für Servicepersonal vor unbeabsichtigtem Kontakt mit den Ausgangsanschlüssen dieser Module vorsehen. Kann aufgrund der Einstellung gefährliche elektrische Energie auftreten, dürfen die Modulanschlüsse für den Benutzer nicht zugänglich sein.

Die Geräteabdeckung/das Gehäuse ist so entworfen, dass das Fachpersonal vor Gefahren geschützt wird. Sie dürfen nicht als Teil der externen Abdeckung für Geräte verwendet werden, die für den Betreiber zugänglich sein müssen, da Teile oder das gesamte Gerätegehäuse unter voller Auslastung übermäßige Temperaturen erreichen kann, die für den Zugang des Betreibers nicht mehr als sicher betrachtet werden.

**Consignes générales de sécurité:**

LIRE LES CONSIGNES DE SECURITE

**Entretien:**

Ces produits ne peuvent pas être réparés par l'utilisateur. Seuls, TDK-Lambda UK LTD et ses agents agréés sont autorisés à effectuer des réparations.

**Composants critiques:**

Ces produits ne doivent pas être utilisés en tant que composants critiques dans des systèmes de commande nucléaire, dans des systèmes de sauvetage ou dans des équipements utilisés dans des environnements dangereux, sans l'autorisation écrite expresse du directeur général de TDK-Lambda EMEA.

**Utilisation du produit:**

Ces produits sont conçus pour être utilisés dans un équipement hôte dont l'accès n'est autorisé qu'aux personnes compétentes.

Ce produit est une alimentation considérée comme un composant devant être installé par des personnes qualifiées, dans un autre équipement. Il ne doit pas être utilisé en tant que produit fini.

Ce produit est destiné à la vente entre entreprises et peut être obtenu via des canaux de distribution.

Il n'est pas prévu à la vente pour les particuliers.

Ce produit est une alimentation considérée comme un composant, il ne relève pas du champ d'application de la directive CEM. Le respect de la directive CEM doit être pris en compte dans l'installation finale. Veuillez contacter votre bureau TDK-Lambda le plus proche.

**Environnement:**

Ces produits sont IPX0, et donc on ne doit pas utiliser des produits chimiques/solvants, des produits de nettoyage et d'autres liquides.

**Environnement fonctionnel :**

Cette alimentation fonctionne en mode commutation pour utilisation dans des applications fonctionnant dans un environnement avec Degré de Pollution 2 et catégorie de surtension II. Elle utilise des cartes des circuits imprimés (PCB) de Groupe IIIb.

**Intensité soutirée:**

L'intensité soutirée de l'alimentation ne doit pas dépasser l'intensité nominale marquée sur la plaque signalétique, sauf indications contraires dans les limitations du produit décrit dans ce manuel.

**Paramètres d'entrée:**

Ce produit doit être utilisé à l'intérieur des paramètres d'entrée indiqués dans les limitations du produit dans ce manuel.

**Elimination en fin de vie:**

L'alimentation contient des composants nécessitant des dispositions spéciales pour leur élimination. Vérifiez que cette alimentation est mise au rebut correctement en fin de vie utile et conformément aux réglementations locales en vigueur.



RISQUE DE CHOC ELECTRIQUE

**Attention-Danger haute tension:**

Des tensions dangereuses sont présentes dans l'alimentation. L'installateur doit protéger le personnel d'entretien contre un contact involontaire avec ces tensions dangereuses dans l'équipement final.

**AVERTISSEMENT:** Si ce produit est installé dans un équipement final de classe I, il doit être mis à la terre de manière fiable et installé par un professionnel averti.

Les sorties (+) ou (-) peuvent être raccordées à la terre ou laissées flottantes.

Le couvercle/châssis de l'alimentation ne doit pas être accessible à l'utilisateur. Le connecteur d'entrée d'alimentation principale ne doit pas être utilisé comme borne de raccordement.

N'utilisez pas de vis pénétrant dans le module sur une profondeur supérieure à : Voir dessins.

Un fusible interne protège le module et ne doit pas être remplacé par l'utilisateur. En cas de défaut interne, le module doit être renvoyé à TDK-Lambda UK LTD ou l'un de ses agents agréés.

Une enceinte appropriée doit être prévue par l'utilisateur final pour assurer la protection contre les chocs mécaniques, les chocs électriques et l'incendie.

Energies dangereuses :

LS200-7.5; LS200-12; LS200-15; LS200-18; LS200-24; LS200-28; LS200-36; LS200-40; LS200-48; LS200-56.

Certains modules peuvent générer une énergie dangereuse (240 VA) selon le réglage de tension de sortie. Le fabricant de l'équipement final doit assurer la protection des techniciens d'entretien contre un contact involontaire avec les bornes de sortie de ces modules. Si une telle tension dangereuse risque de se produire, les bornes ou les connexions du module ne doivent pas être accessibles par l'utilisateur.

Le couvercle et le châssis du module sont conçus pour protéger des personnels expérimentés. Ils ne doivent pas être utilisés comme couvercles extérieurs d'un équipement, accessible aux opérateurs car en condition de puissance maximum, des parties du châssis peuvent atteindre des températures considérées comme dangereuses pour l'opérateur.

**Norme generali di sicurezza:**

SI PREGA DI LEGGERE LE NORME DI SICUREZZA

**Manutenzione:**

Il cliente non può eseguire alcuna manutenzione su questi prodotti. L'esecuzione delle eventuali riparazioni è consentita solo a TDK-Lambda UK LTD e ai suoi agenti autorizzati.

**Componenti critici:**

Non si autorizza l'uso di questi prodotti come componenti critici all'interno di sistemi di controllo nucleari, sistemi necessari alla sopravvivenza o apparecchiature destinate all'impiego in ambienti pericolosi, senza l'esplicita approvazione scritta dell'Amministratore Delegato di TDK-Lambda EMEA.

**Uso dei prodotti:**

Questi prodotti sono progettati per l'uso all'interno di un'apparecchiatura ospite che limiti l'accesso al solo personale competente e autorizzato.

Questo prodotto è da considerarsi come un alimentatore professionale componente e come tale deve essere installato da personale qualificato all'interno di altre apparecchiature e non può essere utilizzato come prodotto indipendente.

Questo prodotto non è inteso per la vendita al dettaglio o agli utilizzatori finali.

Questo alimentatore è da considerarsi come un componente e come tale non è assoggettato dagli scopi della direttiva EMC. Conformità alla direttiva EMC deve essere considerata nell'installazione finale di utilizzo. Gli uffici di TDK-Lambda Sas Succursale Italiana sono a vostra disposizione per ulteriori raggugli.

**Condizioni ambientali:**

Questi prodotti sono classificati come IPX0, dunque non devono essere utilizzati sostanze chimiche/solventi, prodotti per la pulizia o liquidi di altra natura.

**Ambiente:**

Questo prodotto è un alimentatore a commutazione, destinato all'uso in applicazioni rientranti in ambienti con le seguenti caratteristiche: Livello inquinamento 2, Categoria sovratensione II. Questo prodotto contiene schede di circuiti stampati in materiali di Gruppo IIIb.

**Carico in uscita:**

La potenza in uscita ottenuta dall'alimentatore non deve superare la potenza nominale indicata sulla targhetta dell'alimentatore, fatto salvo dove indicato nei limiti per il prodotto specificati in questo manuale.

**Parametri di alimentazione:**

Questo prodotto deve essere utilizzato entro i parametri di alimentazione indicati nei limiti per il prodotto, specificati in questo manuale.

**Smaltimento:**

L'unità contiene componenti che richiedono procedure speciali di smaltimento. Accertarsi che l'unità venga smaltita in modo corretto al termine della vita utile e nel rispetto delle normative locali.



RISCHIO DI SCOSSA ELETTRICA

**Avvertimento di alta tensione:**

All'interno dell'alimentatore sono presenti tensioni pericolose. Gli installatori professionali devono proteggere il personale di manutenzione dal rischio di contatto accidentale con queste tensioni pericolose all'interno dell'apparecchiatura finale.

**ATTENZIONE:** Se installato in un'attrezzatura di classe I, questo prodotto deve essere collegato a terra in modo affidabile ed installato in modo professionale.

Le uscite (+) o (-) possono essere messa a terra o lasciate isolate.

I coperchi/il telaio dell'unità non devono essere accessibili da parte dell'utente.

Il connettore dell'alimentazione principale non può essere utilizzato come terminale di collegamento di campo.

Non utilizzare viti che penetrano nell'unità per più di : Vedi disegni

Un fusibile interno protegge l'unità e non deve essere sostituito dall'utente. Nell'eventualità di un difetto interno, restituire l'unità a TDK-Lambda UK LTD o a uno dei suoi agenti autorizzati.

L'apparecchiatura finale deve includere una recinzione meccanica, elettrica e antincendio per proteggere dai pericoli di natura meccanica, dalle scosse elettriche e dai pericoli di incendio.

Pericoli energetici:

LS200-7.5; LS200-12; LS200-15; LS200-18; LS200-24; LS200-28; LS200-36; LS200-40; LS200-48; LS200-56.

Alcuni moduli sono in grado di erogare energia pericolosa (240 VA) a seconda della tensione in uscita impostata. I produttori delle apparecchiature finali sono tenuti a proteggere il personale di manutenzione dal rischio di contatto accidentale con questi terminali dei moduli di uscita. Se impostati su livelli che non escludono l'erogazione di energia pericolosa, questi terminali o collegamenti non devono risultare accessibili da parte dell'utente.

Il coperchio/telaio dell'unità è realizzato per proteggere il personale esperto dai pericoli. Non deve essere usato come parte degli involucri esterni di qualsiasi apparecchiatura, se risulta accessibile da parte degli addetti, poiché è possibile che in condizioni di pieno carico una o più parti del telaio dell'unità giunga/ giungano a temperature superiori ai limiti considerati sicuri per l'accesso da parte degli addetti.



**Instrucciones generales de seguridad:**

LEA LAS INSTRUCCIONES DE SEGURIDAD

**Servicio:**

Estos productos no pueden ser reparados por los clientes. TDK-Lambda UK LTD. y sus agentes autorizados son los únicos que pueden llevar a cabo las reparaciones.

**Componentes fundamentales:**

Estos productos no pueden ser utilizados como componentes fundamentales en sistemas de control nuclear, sistemas de soporte vital o equipos a utilizar en entornos peligrosos sin el consentimiento expreso por escrito del Director General de TDK-Lambda EMEA.

**Uso de los productos:**

Estos productos han sido diseñados para ser utilizados en un equipo central que restrinja el acceso al personal cualificado autorizado.

Este producto es una fuente de alimentación y sólo puede ser instalado por personal cualificado dentro de otros equipos y no debe ser tratado como un producto independiente. Este producto debe ser vendido entre empresas profesionales y solo puede obtenerse a través de los canales de distribución. No está destinado para la venta a usuarios finales.

Este producto es una fuente de alimentación y no se ve afectada por la directiva EMC. El cumplimiento de la directiva EMC se debe considerar en la instalación final. Por favor, póngase en contacto con su oficina local de TDK - Lambda.

**Medioambiental:**

Estos productos son IPX0 y, por tanto, no pueden utilizarse sustancias químicas/disolventes, agentes de limpieza ni otros líquidos.

**Medio ambiente:**

Esta fuente de alimentación es una fuente de alimentación de modo conmutado a utilizar en aplicaciones dentro de un entorno con un Grado de contaminación 2 y una Categoría de sobretensión II. En él se utilizan policloruros de bifenilo del Grupo de materiales IIIb.

**Carga de salida:**

La potencia de salida tomada de la fuente de alimentación no puede sobrepasar el valor nominal indicado en la etiqueta de la fuente de alimentación, excepto en los casos indicados en las limitaciones del producto en este manual.

**Parámetros de entrada:**

Este producto debe ser utilizado dentro de los parámetros de entrada indicados en las limitaciones del producto en este manual.

**Desecho de la unidad:**

La unidad contiene componentes que deben ser desechados de una manera especial. Asegúrese de desechar correctamente la unidad al final de su vida útil y conforme a las normas locales vigentes.



PELIGRO DE DESCARGAS ELÉCTRICAS

**Advertencia de alta tensión:**

En esta fuente de alimentación hay tensiones peligrosas. El instalador profesional debe proteger al personal de servicio contra cualquier contacto accidental con estas tensiones peligrosas en el equipo final.

**ADVERTENCIA:** La instalación de este producto en un equipo de clase I la deben llevar a cabo profesionales y el producto debe estar conectado a tierra.

La salida o salidas (+) o (-) pueden conectarse a tierra o se las puede dejar flotando.

Debe impedirse el acceso de los usuarios a la cubierta o cubiertas y al chasis de la unidad.

El conector de entrada de la red no es apto para ser utilizado a modo de bornes de cableado de campo.

No utilice tornillos de montaje susceptibles de penetrar en la unidad más de: Ver dibujos.

Un fusible interno protege la unidad y este no debe ser nunca reemplazado por el usuario. En caso de existir algún defecto interno, la unidad debe ser enviada a TDK-Lambda UK LTD o a uno de sus agentes autorizados.

El equipo de uso final debe constituir un recinto de protección mecánica, eléctrica y contra incendios de protección mecánica, contra descargas eléctricas y contra el peligro de incendios.

Peligros de energía:

LS200-7.5; LS200-12; LS200-15; LS200-18; LS200-24; LS200-28; LS200-36; LS200-40; LS200-48; LS200-56.

Algunos módulos pueden generar energía peligrosa (240VA) dependiendo de la configuración de la tensión de salida. Los fabricantes de equipos finales deben proteger al personal de servicio contra un contacto accidental con estos bornes de salida de los módulos. Si se configura de modo que pueda generarse energía peligrosa, hay que evitar que el usuario pueda acceder a los bornes o conexiones del módulo.

La cubierta/chasis de la unidad ha sido diseñada para que proteja a las personas cualificadas de los peligros. No deben ser utilizadas como parte de las cubiertas externas de cualquier equipo al que pueden acceder los operarios, ya que bajo unas condiciones de carga completa, la pieza o piezas del chasis de la unidad pueden alcanzar temperaturas superiores a las consideradas seguras para el acceso de los operarios.

**Instruções gerais de segurança:**

LEIA AS INSTRUÇÕES DE SEGURANÇA

**Manutenção:**

Estes produtos não são podem ser submetidos a manutenção por parte do cliente. Apenas a TDK-Lambda UK LTD e os seus agentes autorizados têm permissão para realizar reparações.

**Componentes essenciais:**

Não é autorizada a utilização destes produtos como componentes essenciais de sistemas de controlo nuclear, sistemas de suporte de vida ou equipamento para utilização em ambientes perigosos sem a expressa autorização por escrito do Director-Geral da TDK-Lambda EMEA.

**Utilização do produto:**

Estes produtos foram concebidos para utilização dentro de um equipamento de alojamento que apenas permita o acesso a pessoal qualificado autorizado.

Este produto é uma alimentação considerado com um componente para ser instalado por pessoas qualificadas, em outros equipamentos. Não deve ser usado como um produto acabado.

Este produto é destinado para venda entre as empresas e pode ser obtido através de canais de distribuição. Não se destina à venda aos particulares.

Este produto é uma alimentação considerado com um componente, não é dentro do application âmbito da directiva CEM.

Conformidade com a directiva CEM devem ser considerados na instalação final.

Entre em contacto com seu escritório TDK-Lambda mais próximo.

**Ambiental:**

Estes produtos são IPX0 e, como tal, não se devem utilizar químicos/solventes, agentes de limpeza e outros líquidos.

**Ambiente:**

Esta fonte de alimentação é uma fonte de alimentação do modo de comutação para utilização em aplicações com um Nível de Poluição 2 e ambientes da categoria de sobretensão II. São utilizadas placas de circuitos impressos do grupo de materiais IIIb.

**Carga de saída:**

A potência de saída extraída da fonte de alimentação não deve exceder a classificação assinalada na etiqueta da fonte de alimentação, excepto quando indicado nas limitações do produto neste guia.

**Parâmetros de entrada:**

Este produto deve ser utilizado dentro dos parâmetros de entrada indicados nas limitações do produto neste guia.

**Eliminação no fim de vida:**

A unidade contém componentes que necessitam de procedimentos especiais de eliminação. Certifique-se de que a unidade é devidamente eliminada no fim da sua vida útil e que tal é feito em conformidade com os regulamentos locais.



RISCO DE CHOQUE ELÉCTRICO

**Aviso de alta tensão:**

Estão presentes tensões perigosas dentro da fonte de alimentação. O profissional que realizar a instalação deve proteger o pessoal de assistência contra contactos inadvertidos com estas tensões perigosas do equipamento final.

**AVISO:** Quando instalado num equipamento de Classe I, este produto deve ser ligado à terra de forma fiável e instalado por um profissional.

As saídas (+) e (-) podem ser ligadas à terra ou deixadas soltas.

O chassis/cobertura(s) da unidade não deve estar acessível ao utilizador.

O conector de entrada de alimentação não deve ser utilizado como terminal de cablagens no local.

Não utilize parafusos de montagem, uma vez que estes penetrarão na unidade em mais do que: Veja os desenhos

Existe um fusível interno que protege a unidade e que não deve ser substituído pelo utilizador. Em caso de defeito interno, a unidade deve ser devolvida à TDK-Lambda UK LTD ou a um dos seus agentes autorizados.

O equipamento de utilização final deve fornecer um bastidor com protecção mecânica, eléctrica e contra incêndios adequada.

Perigos de energia:

LS200-7.5; LS200-12; LS200-15; LS200-18; LS200-24; LS200-28; LS200-36; LS200-40; LS200-48; LS200-56.

Alguns módulos tem a capacidade de fornecer energia perigosa (240 VA), de acordo com a configuração da tensão de saída. O equipamento final do fabricante deve garantir que o pessoal de assistência está protegido contra contactos inadvertidos com estes terminais de saída do módulo. Se essa energia perigosa for produzida, as ligações e os terminais do módulo não devem ser acessíveis pelos utilizadores.

O chassis/cobertura da unidade está concebido de forma a proteger o pessoal especializado de perigos. Não devem ser utilizados como parte das coberturas externas de qualquer equipamento em que possam estar acessíveis aos operadores, uma vez que em condições de carga máxima, algumas peças do chassis da unidade podem atingir temperaturas superiores às consideradas seguras para o acesso do operador.

## **TDK·Lambda**

TDK-Lambda UK Ltd

Kingsley Avenue, Ilfracombe

Devon, EX34 8ES

Telephone - Sales and Service +44 (0)1271 856666

Head Office and Works +44 (0)1271 856600

Facsimile +44 (0)1271 864894

WEBSITE: [www.uk.tdk-lambda.com](http://www.uk.tdk-lambda.com)

# *LS200 Series*

## *Instruction Manual*

### **BEFORE USING THE POWER SUPPLY UNIT**

Pay attention to all warnings and cautions before using the unit. Incorrect usage may lead to an electrical shock, damage to the unit or a fire hazard.

### **WARNING and CAUTION**

- Do not modify.
- Do not touch the internal components; it may have high voltage or high temperature. You may get electrical shock or burn.
- When the unit is operating, keep your hands and face away from it as you may be injured by flying debris in the event of a fault.
- This power supply is designed for use within an end product. Stick the WARNING label for users on the system equipment and notify in the system instruction manual.
- Never operate the unit under over current or short-circuit conditions for more than 30 seconds or outside its specified Input Voltage Range, which could result in damage but there is no possibility of fire or burning.
- Confirm connections to input/output terminals are correct as indicated in the instruction manual.
- Hazardous voltage may appear at output terminals depending on the type of failure. The outputs of these products must be earthed in the end equipment to maintain SELV.  
If the outputs are not earthed, they must be considered hazardous and must not be made user accessible.

### **Note: CE MARKING**

CE marking, when applied to the LS series products, indicates compliance with the Low Voltage Directive (2014/35/EU) in that it complies with EN60950-1 2nd edition.

<b>DWG NO. : PA607-04-01D</b>		
<b>APPD</b>	<b>CHK</b>	<b>DWG</b>

## 1. Terminal Explanation

Please pay extra attention to the wiring. Incorrect connection may cause damage to the power supply.

- When connecting input and output wiring, input AC-Line should be OFF.
- Input wiring and output wiring shall be separated, otherwise noise susceptibility of power supply unit will be weak.
- The protective earth (PE) must be connected to the instrument chassis and the chassis of this power supply unit.
- Remote sensing lines shall be twisted or use shielded wire.
- Remote ON/OFF control lines shall be twisted or use shielded wire.

### 1-1. Front Panel Explanation

- |     |                    |   |
|-----|--------------------|---|
| (1) | L : Input terminal | Live line (Fuse in line)                      |
| (2) | N : Input terminal | Neutral line                                  |
| (3) | FG $\perp$ :       | Frame Ground                                  |
| (4) | - V :              | - Output terminal                             |
| (5) | +V :               | + Output terminal                             |
| (6) |                    | Output voltage adjustable trimmer             |
| (7) |                    | Output monitoring indicator (Green LED : ON)  |
| (8) |                    | CN2: Remote sensing and ON/OFF control signal |

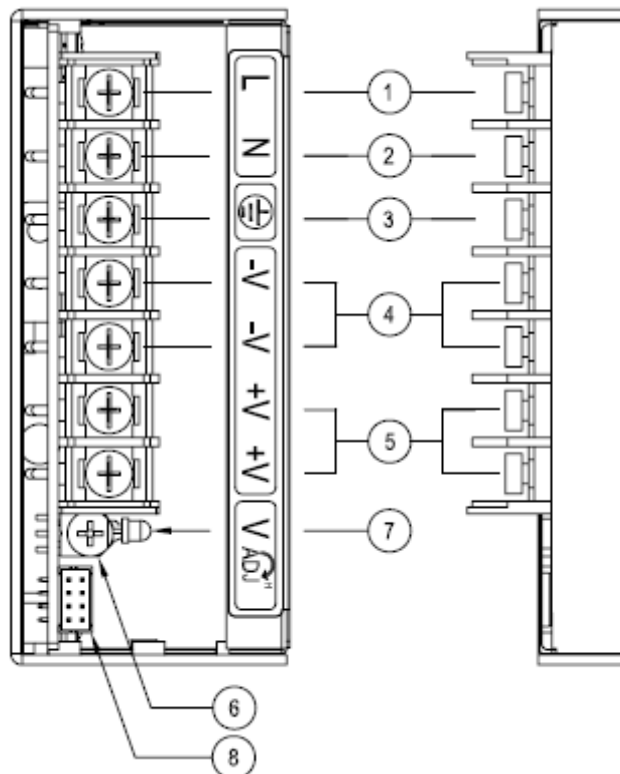

## 2. Terminal Connecting Method

### 2-1. Terminal connecting method

- Input must be off before making connection.
- Connect FG terminal to ground terminal of the equipment.
- The output load line and input line shall be separated and twisted to improve noise immunity.

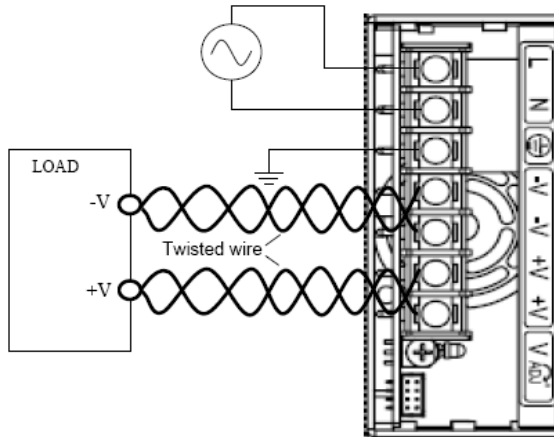

Maximum output current of each output terminal is 20A. If more than 20A, use 2 terminals.

### 2-2. CN2 Connector pin configuration and function

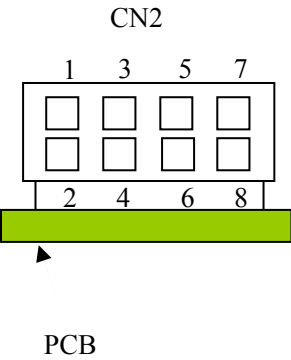
	Pin No.	Configuration	Function
		1	+Vm
	2	+S	Remote sensing terminal for +Output (For remote sensing function, this compensates for line drop between power supply terminals and load terminals. Connect to +Vm terminal when remote sensing function is not required)
	3	-Vm	Connected to -Output terminal of the power supply unit. (-Vm terminal cannot supply load current)
	4	-S	Remote sensing terminal for -Output (For remote sensing function, this compensates for line drop between power supply terminals and load terminals. Connect to -Vm terminal when remote sensing function is not required)
	5	NC	No connection
	6	NC	No connection
	7	CNT+	Remote ON/OFF control terminal (Apply 3 to 12V to CNT+ to turn power supply OFF. Otherwise pull low)
	8	CNT-	Return loop for CNT+ signal

### 2.3. Basic connection (Local sensing)

- (1) Connect "+S" terminal to "+Vm" terminal with sensing wire
- (2) Connect "-S" terminal to "-Vm" terminal with sensing wire
- (3) Connect "CNT+" terminal to "CNT-" terminal with wire

- Please use attached CN2 connector for each connection.

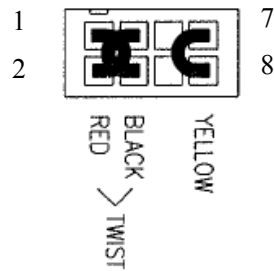

### 2-4. Remote sensing (+S, -S terminal)

- (1) Connect "+S" terminal to "+V" terminal of load with sensing wire
- (2) Connect "-S" terminal to "-V" terminal of load with sensing wire
- (3) Connect "CNT+" terminal to "CNT-" terminal with wire

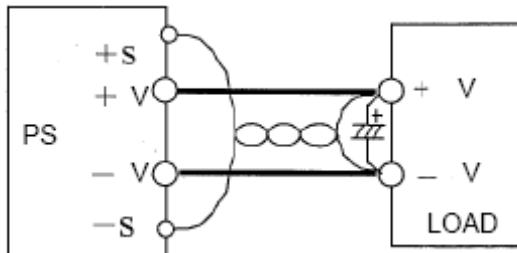

If remote sensing terminal are opened, the stability and the accuracy of out deteriorated. Therefore, terminal +S, -S must be connected.

Even when the supplied CN2 socket is not plugged in, the power supply will not go to OVP as there is already an internal 10 ohm resistor connected to the output terminals.



### 3. Explanation of Functions and Precautions

#### 3-1. Input Voltage Range

Input voltage range is single phase 85 ~ 264VAC (47 ~ 63Hz) or 120 ~ 373VDC.  
 Input voltage which is out of specification, may damage the unit. For cases where conformance to various safety specifications (UL, CSA, EN) are required, input voltage range shall be 100~240VAC (50/60Hz).

Note: LS200 series is able to withstand Input Surge of 300VAC for 5 seconds.

#### 3-2. Output Voltage Range

V.ADJ trimmer is for output voltage adjustment within the range of specifications. Turning the trimmer clockwise will increase the output voltage. Kindly note that Over Voltage Protection (OVP) function may trigger if the output voltage is increased excessively. Please ensure that the output power is below the rated output power, and output current is below the maximum output current (3.3V ~ 15V and 48V) or below the peak output current (24V ~ 36V) when output voltage is raised.

#### 3-3. Inrush Current

Power Thermistor is built in to protect the circuit from high Inrush Current. Please select suitable input switch and fuse rating in case of re-input the power at high temperature.

#### 3-4. Over Voltage Protection (OVP)

The OVP function will shutdown the output. The input shall be removed for a few minutes to discharge the power unit, before turn ON the AC input again to recovery the output. OVP setting is fixed and cannot be adjusted externally.

#### 3-5. Over Current Protection (OCP)

OCP function activates when the output current exceeds the specified OCP limit. The output will automatically recover when the overload condition is removed. Do not operate overload or dead short conditions for more than 30 seconds, which could result in damaging the power unit. However, there is no possibility of fire or burning.

#### 3-6. Over Temperature Protection (OTP)

Over Temperature Protection function (manual reset type) is available. When ambient or internal temperature rises abnormally, OTP function will shut down the output. To recover the unit, first shut down the AC input and let the unit cool down before turning ON the AC input.

#### 3-7. Remote Sensing (+S, -S terminal)

Remote sensing function is provided to compensate for voltage drop across the wiring from the power supply output terminals to the load input terminals. Connect “+S” terminal to “+V” terminal of the load and “-S” terminal to the “-V” terminal of the load with sensing wires. The total line voltage drop (+Vm side line and -Vm side line) shall be less than 0.3V. In the case that sensing wires are too long, it is necessary to put an electrolytic capacitor across the load terminals. Example of external capacitor is listed in the table below :

	Minimum external capacitance at the load input terminal							
MODEL	3.3V	5V	7.5V	12V	15V	24V	36V	48V
LS200	2,200uF					1,000uF	470uF	

Please take note that the electrolytic capacitor will generate heat etc. This is caused by the ripple current generated in proportion to the load connected. Therefore, the electrolytic capacitor used must have a ripple current allowance higher than the actual output ripple current.

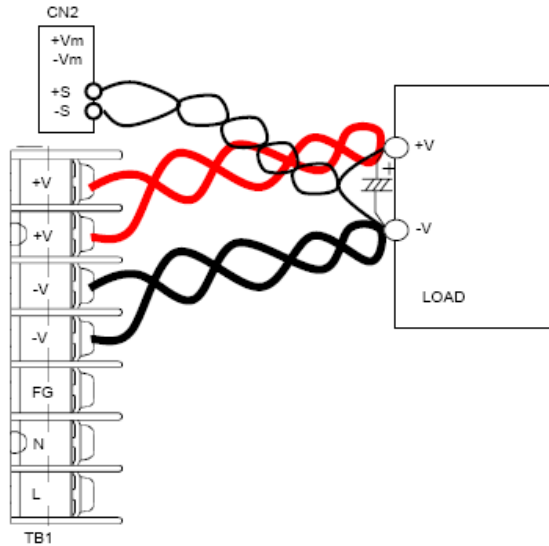

When not using the remote sensing function, +S & -S terminal shall be connected to +Vm & -Vm terminals of CN2 respectively.

Please use the attached connector of CN2 for this purpose.

This is to ensure stability and accuracy of the output.

### 3-8. Remote ON/OFF Control

Remote ON/OFF control is available.

Output can be remotely switched OFF by connecting an external logic high signal to CNT+ terminal versus CNT- terminal. Apply 3 to 12V to CNT+ to turn power supply OFF. Otherwise pull low.

CNT+ Level versus CNT- terminal	Output
0 ~ 0.8V	ON
3 ~ 12V	OFF

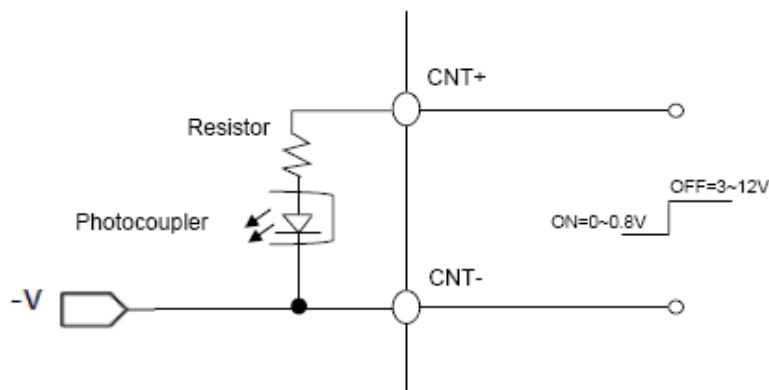

CNT- terminal is internally connected to -V negative output of the power supply unit.

When not using the remote ON/OFF function, CNT+ terminal must be shorted to CNT- terminal with the attached connector shown in 2-3.

### 3-9. Output Ripple & Noise

Ripple & noise are measured at 20MHz using a 300mm twisted pair of load wires terminated with a 0.1uF film capacitor & 47uF electrolytic capacitor. When load lines are longer, ripple becomes larger. The output ripple cannot be measured accurately if the probe ground lead of oscilloscope is too long. At low temperature, large ripple & noise is visible due to large ESR of the internal Electrolytic Capacitors especially at -25 °C. Output voltage rise may not be smooth during initial turn on at low temperature.

### 3-10. Series Operation

For series operation, either method (A) or (B) is possible.

Method ( A )

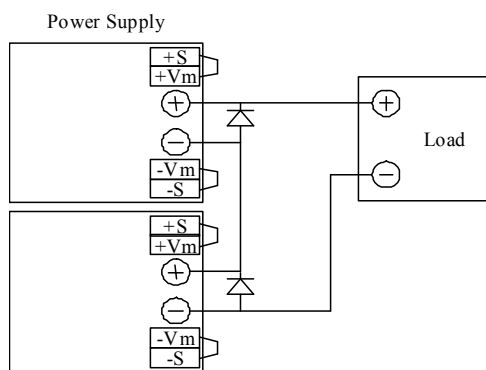

Method ( B )

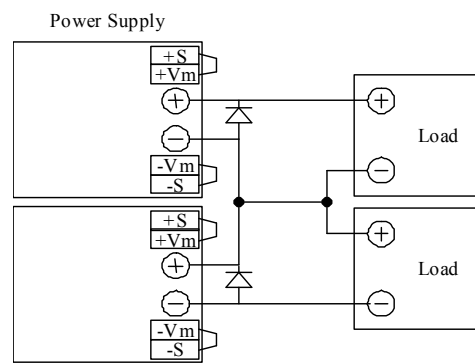

Note: In case of Method (A), please connect diodes to prevent the reverse voltage.

### 3-11. Parallel Operation

(A)

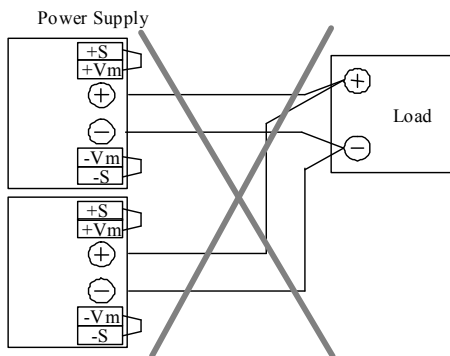

(B)

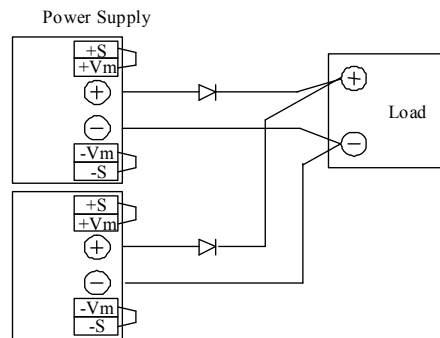

- (A) Operation to increase the Output Current is not possible.
- (B) Operation as a Backup Power Supply is possible as follows:
- (1) Set the power supply output voltage higher by the amount of forward voltage drop ( $V_F$ ) of the diode.
  - (2) Please adjust the output voltage of each power supply to be the same.
  - (3) Please use within the specifications for output voltage and output current.  
 Connect "CNT+" terminal to "CNT-" terminal with wire CN2 connector.

### 3-12. Output Peak Power

Operating conditions for peak power/current models:

- (a) Reduce peak current according to output derating curve for higher ambient temperature (see section 5.1)
- (b) Output might shut down when the rated current or the continuous peak output time ( $\tau$ ) exceeded rated value specified. Power supply may shut down and operate in hiccup or constant current limiting mode.

Input voltage : 115 ~ 230 VAC +/- 20% (50/60 Hz)  
 Continuous peak out time ( $\tau$ ) : < 10s  
 Peak output current ( $I_p$ ) : Within the rated peak output current

Duty: not more than 35%

$$\text{Duty} = \frac{\tau}{T} \times 100 (\%)$$

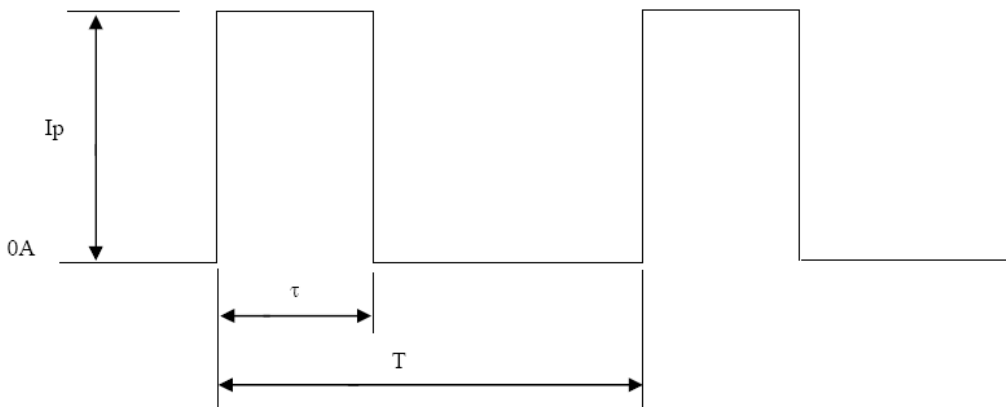

$$\sqrt{I_p^2 \times \frac{\tau}{T}} < I_{rms \max}$$

Applicable model for Peak Output Power:

Model	I <sub>rms max.</sub>
LS200-24	6.15 A
LS200-36	4.10 A

## 4. Isolation / Withstand Voltage

### 4-1. Isolation Test

Isolation resistance between output and FG (chassis) shall be more than 100MΩ at 500VDC. For safety purposes, voltage setting on DC isolation tester must be done before the test. Ensure that the unit is fully discharged after the test.

Output ~ FG (chassis): 500VDC, 100MΩ or more

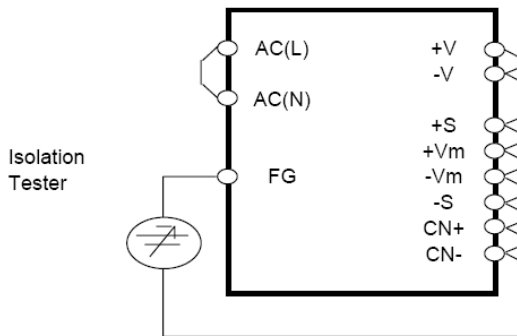

### 4-2. Withstand Voltage

This series is designed to withstand 3.0kVAC between input and output, 1.5kVAC between input and FG (chassis) and 500VAC between output and FG (chassis) each for 1 minute. When testing withstands voltage, set current limit of withstand voltage test equipment at 20mA (Output-FG (chassis): 100mA). The applied voltage must be gradually increased from zero to testing value and then gradually decreased for shut down. When timer is used, the power supply may be damaged by high impulse voltage at timer switch on and off. Connect input and output as follows :

(a) Input ~ FG (chassis) : solid line  
 1.5kVAC, 1min (20mA)

(c) Output ~ FG (chassis) : 500VAC  
 1min (100mA)

(b) Input ~ Output : dotted line  
 3kVAC, 1min ( 20mA )

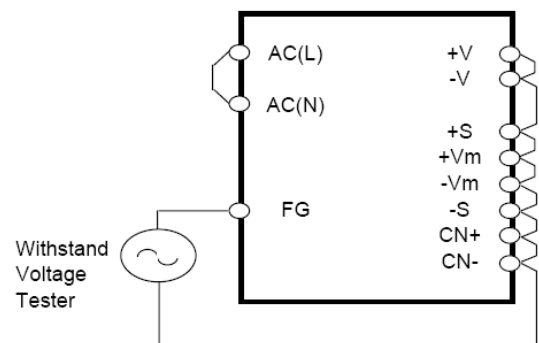
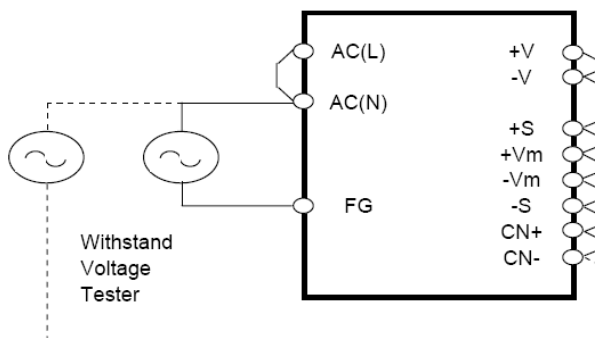

## 5. Mounting Directions

### 5-1. Output Derating according to the Mounting Directions

(a) Forced air convection, with FAN & cover (Exhale)  
(LS200 Series)

Recommended standard mounting is Method (A).  
Method (B) and (C) are also possible.  
Refer to the Output Derating below.  
Please do not use installation Method (D), (E) and (F).

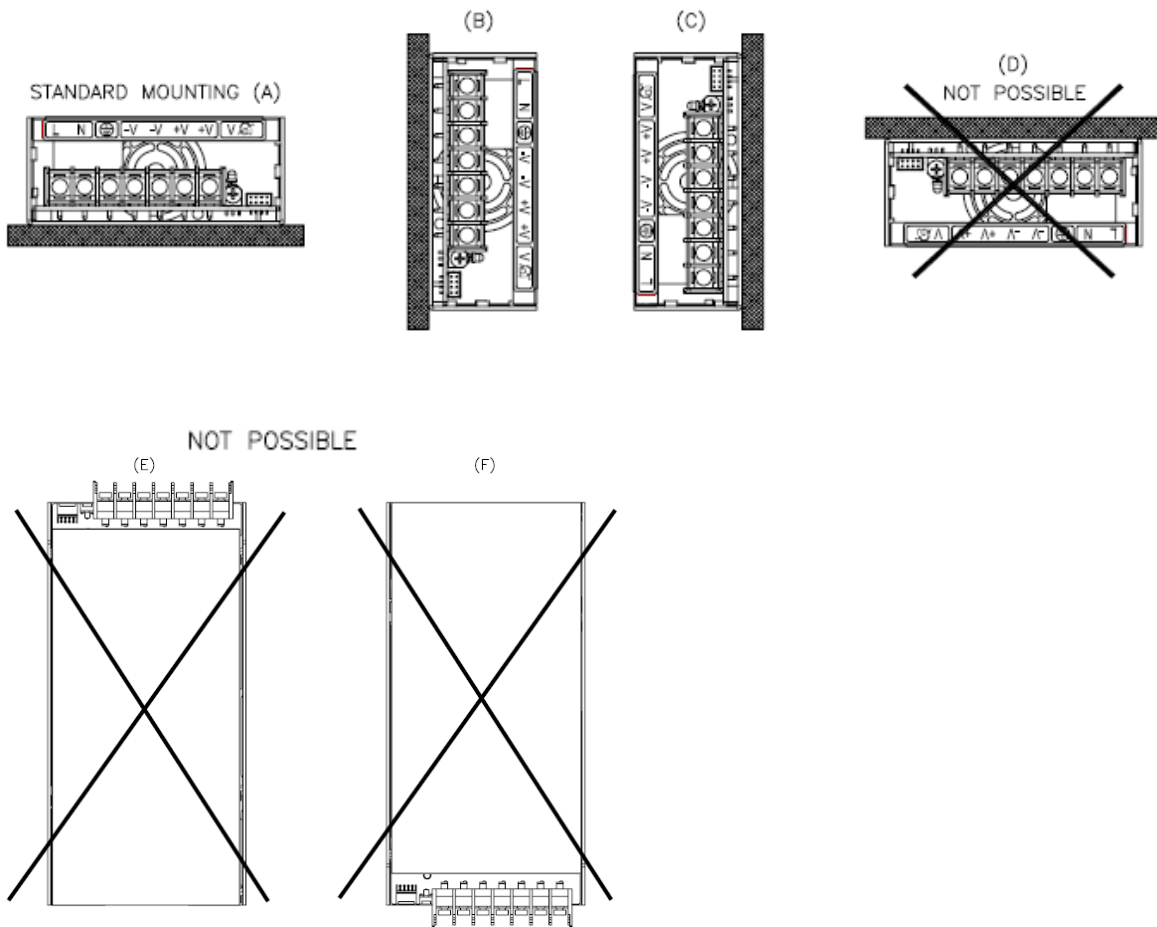

(b) Free air convection, without Fan & Cover  
(LS200/L Series)

Recommended standard mounting is Method (A).  
Method (B), (C), (E) and (F) are also possible.  
Refer to the Output Derating below.  
Please do not use installation Method (D).

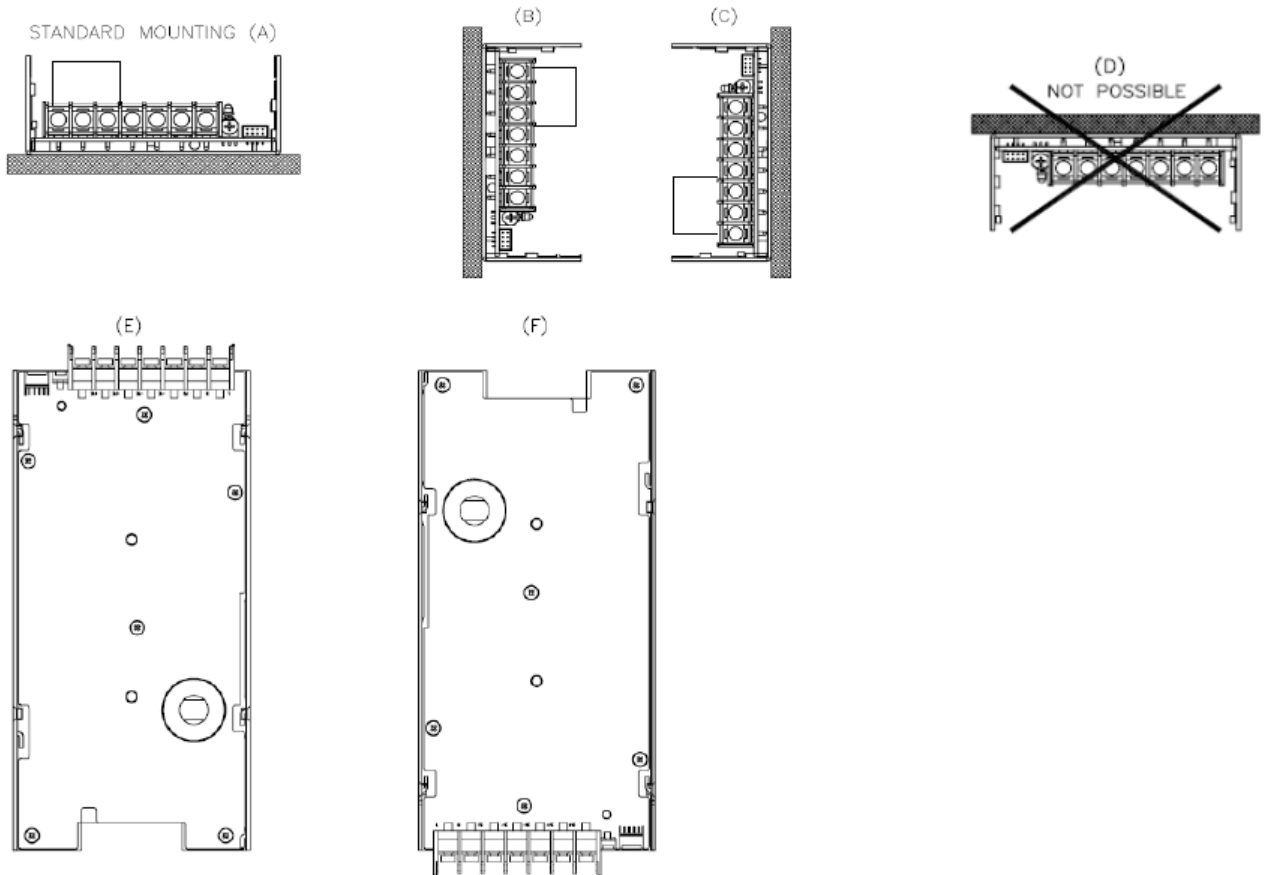

**5-2. Output Derating according to the ambient temperature**

(A) LS200 series Output Derating versus Ambient Temperature.

The cooling system is forced air (exhale).

In the following derating curve, the maximum output current please refers to PA607-01-01.

LS200 – 3.3V, 5V, 7.5V, 12V, 15V, 24V, 36V & 48V

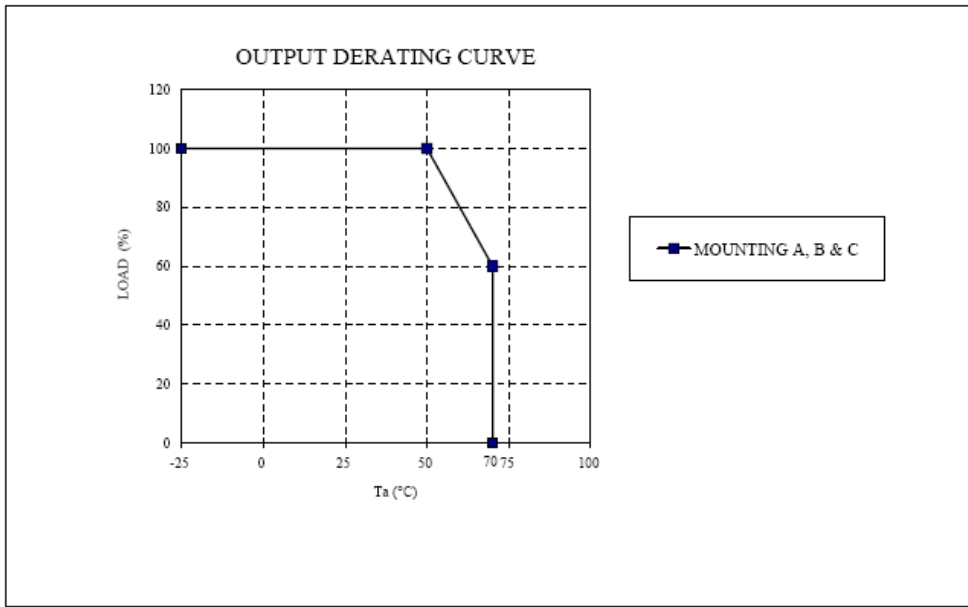

(B) LS200/L series Output Derating versus Ambient Temperature.

The cooling system is convection cool or forced air (exhale) with airflow > 3m/s.

In the following derating curve, the Y-axis for maximum output current please refers to PA607-01-01/L.

i. LS200/L – 3.3V, 5V & 7.5V

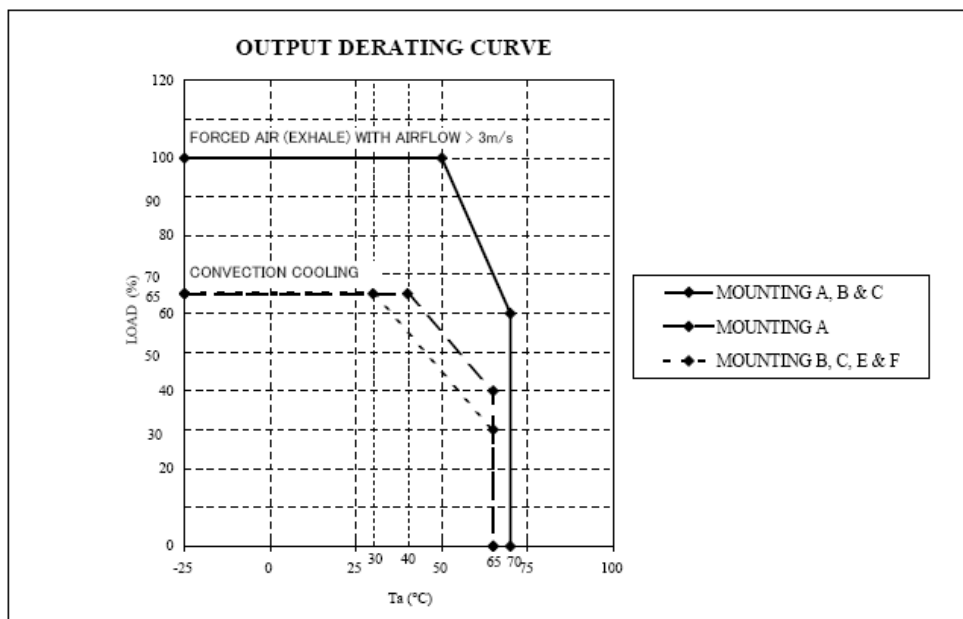



ii. LS200/L – 12V, 15V, 24V, 36V & 48V

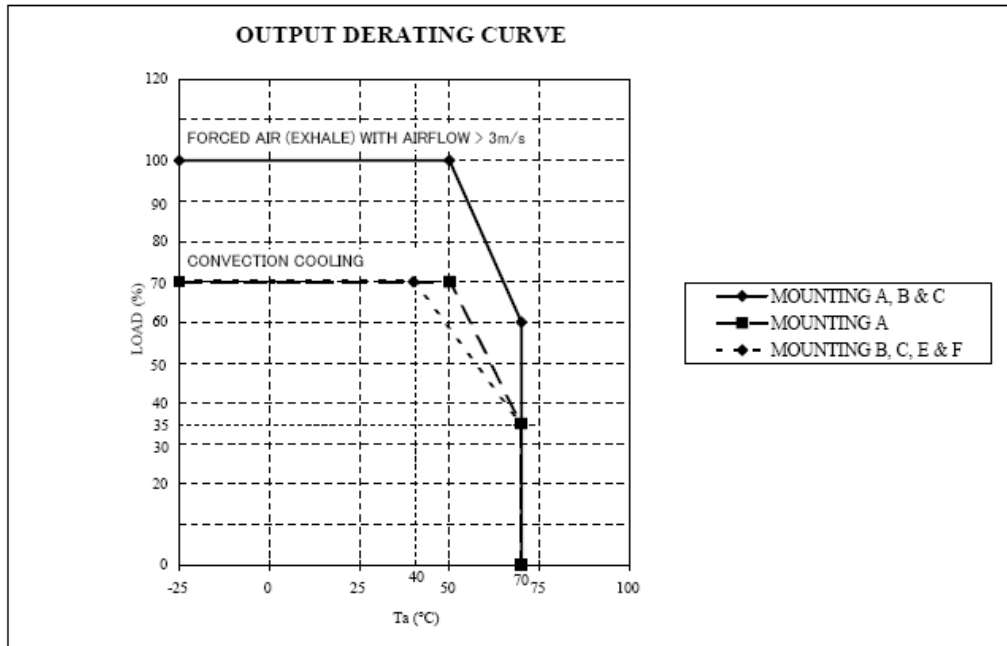

(C) LS200/L series for Output Derating versus Input Voltage.

The cooling system is convection cool or forced air (exhale) with airflow > 3m/s.

In the following derating curve, the Y-axis for maximum output current please refers to PA607-01-01/L.

LS200/L – 3.3V, 5V, 7.5V, 12V, 15V, 24V, 36V & 48V

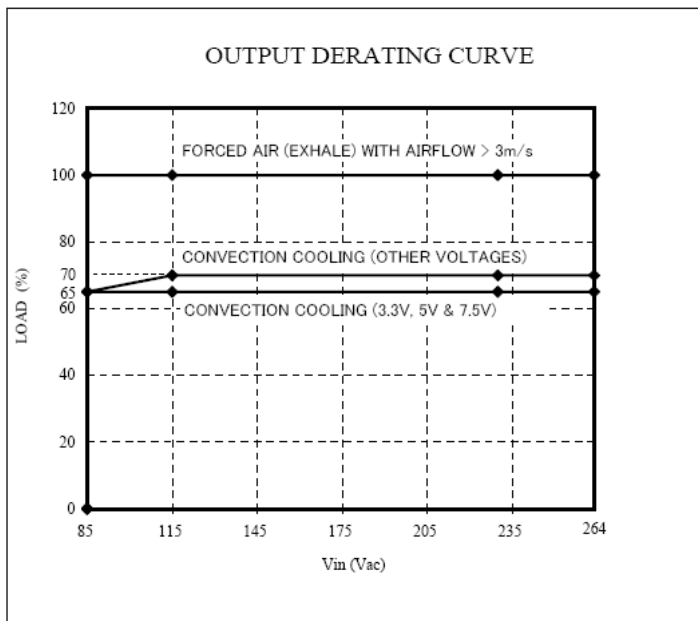

(D) LS200/L series Output Derating versus Ambient Temperature.

The Output Derating with external fan (exhale) depends on the airflow conditions and the temperature rise for the components.

The method stipulated below provide a way to decide for the safe operation of this power supply. As shown, this table provides a list of the maximum temperature allowed for specified components. The component temperature is measured according to IEC60950-1 2<sup>nd</sup> edition Clause 4.5.

Maximum rated temperature for these components are taken from the component specification provided by the original manufacturers. These are the worse case allowable temperature.

Temperature is measured using thermal couple K-type, and using CYANOACRYLATE adhesive or equivalent to secure to the hottest point of these components.

In order to decide the worse case temperature rise, the selected measurement point should not face direct airflow and the equipment powered should operate under worse case operating conditions.

Location No	Parts Name	Maximum Temperature (°C) *1
Q1, Q2	Mosfet	110 (130)
D1	Bridge Diode	110 (130)
D4	Fast Recovery Diode	100 (130)
D12	Output Diode	100 (130)
C10, C30, C36 & C37	Electrolytic Capacitor	80 (105)
L1	Balun Coil	100 (130)
L5, L14	Choke Coil	100 (130)
T1	Transformer	100 (110)

\*1. Absolute temperature (Maximum temperature) during normal operating conditions. Higher temperature will probably cause shorter life span for the power supply.

Please refer to the component side layout drawing below for temperature measurement.

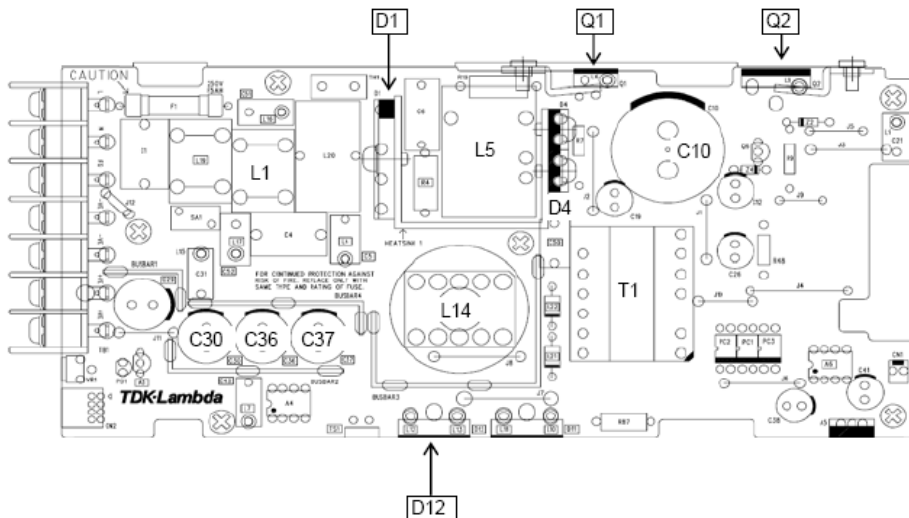

### 5-3. Mounting Method

- 1) This power supply unit is a forced air-cooling system with a built-in fan.
- 2) This power supply has ventilation holes in front and the back.  
 In consideration of the heat radiation and safety, please keep a distance of more than 100mm from front side and more than 50mm from rear side.
- 3) Please note that ventilation will be worsened in a dusty environment.
- 4) Built in fan is limited life part, which requires periodic replacement. (Replacement will be charged).
- 5) The ambient temperature of this power supply is less than 50mm from the center of the front side.
- 6) Maximum allowable penetration of mounting screws into the power-supply is 5mm.
- 7) Recommended torque for mounting screws (M4): 1.27 N·m (13.0 kgf·cm).

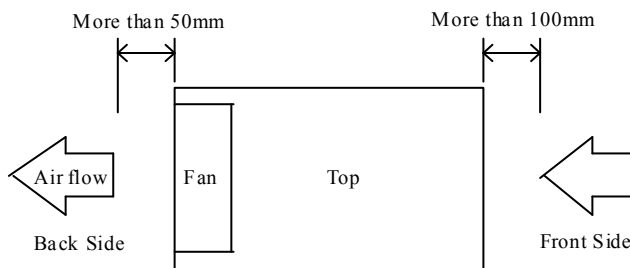

### 6. Wiring Method

- The input and output load wires shall be separated and twisted to improve noise immunity.
- Both wires must be as thick and short as possible to have lower impedance.
- Noise can be reduced by connecting a film capacitor with 0.1uF capacitance across the load terminals.
- For safety and EMI considerations, connect the FG terminal of LS200 series to mounting set ground terminal.
- The recommended wire type :

MODEL	Recommended Wire	Recommended torque	Recommended crimp-type terminal		
			D (MAX)	t (MAX)	Mounting Pieces (MAX)
LS200	AWG14-22	M3.5 Screws 1.0 N·m (9.8 kgf·cm) ~ 1.4 N·m (13.7 kgf·cm)	6.8mm	0.8mm	2 pieces

Note 1 : When using separate loads, it is recommended to use 2 pieces of 0.8mm thick crimp-type terminal.

Note 2 : For recommended wire diameter, refer to wire maker recommended allowable current and voltage drop. For higher output current model like 3.3V & 5V, bigger diameter wire is recommended.

### 7. External Fuse Rating

Refer to the following fuse rating when selecting the external input fuse. Surge current flows when input is turned on. Fuse rating is specified by Inrush Current value at input turns on. Do not select the fuse according to input current (rms) values under the actual load condition.

LS200 : F5A , 250V

## 8. Fan Life Expectancy.

The fan life has limitation. Following figure shows the life expectancy of fan against temperature.

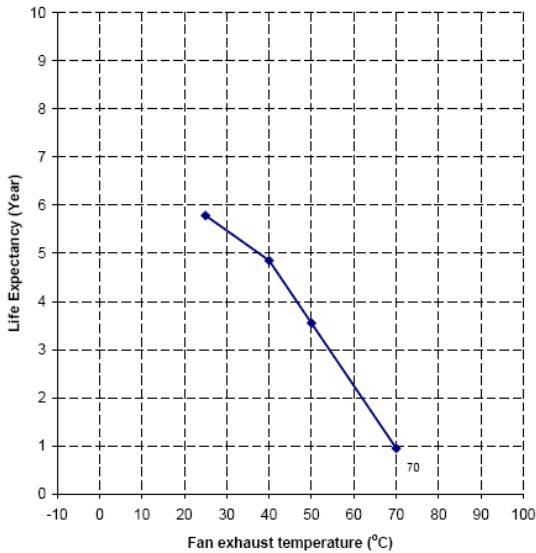

Measurement point of fan exhausts temperature

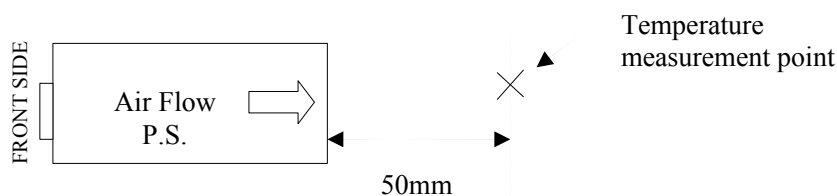

## 9. Before concluding that the unit is at fault...

Please make the following checks.

- (1) Check if the rated input voltage is connected and within specification.
- (2) Check if the wiring of input and output is correct.
- (3) Check if the I/O terminal connection is properly tightened by required torque.
- (4) Check if the wire thickness is enough.
- (5) Check if the output voltage trimmer (V.ADJ) is properly adjusted. OVP might be triggered and output is shutdown.
- (6) Check if the built-in fan is operating. Is fan stopped or blocked by something?
- (7) Power supply has ventilating holes in front and the back. Check if there is any blockage or dust, etc.
- (8) Is the chassis of power supply abnormally hot? The output is shutdown by OTP operation.  
Please disconnect or turn off the AC input and let the unit cool down sufficiently before turning ON the AC input again.
- (9) Check if the output current and output wattage does not exceed the specification.
- (10) Audible noise may be heard when input voltage waveform is not sinusoidal.
- (11) Audible noise may be heard during dynamic load operation.
- (12) Ensure that a large capacitor is not connected across the output terminals. Please use within maximum capacitance shown below.

MODEL	Maximum external capacitance							
	3.3V	5V	7.5V	12V	15V	24V	36V	48V
LS200	10,000uF					5,000uF	1,000uF	

## **10. Warranty Condition**

This product is under warranty for 3 years (based on 8 hours/day operation) from the date of shipment. During the warranty period, TDK-Lambda will, at its option, either repair or replace products prove to be defective.

Warranty applies but not limited to the following.

- (1) Average operating temperature (ambient temperature of the power supply unit) is under 40°C.
- (2) Average load factor is 80% or less.
- (3) Installation method: Standard installation.

Following cases are not covered by warranty.

- (1) Improper usage and mis-handling like dropping or applying shock to the unit and defects from operation exceeding specification of the product.
- (2) Defects resulting from natural disaster (fire, flood).
- (3) Unauthorized modification or repair.