

LIQUID CRYSTAL DISPLAY MODULE

Product Specification

DENSITRON	STANDARD LCD MODULE	
PRODUCT NUMBER	LWM2004A-B	
DEFINITION	20 characters x 4 lines	Date 01/08/2008

INTERNAL APPROVALS				
Quality Mgr	Product Mgr	Project Leader	Mech. Eng	Electr. Eng
Pat CHANG	Stéphan KIEFFER	Adrian SMYTH	Pat CHANG	Eric HUNG
Date: 06/08/08	Date: 06/08/08	Date: 06/08/08	Date: 06/08/08	Date: 06/08/08

Densitron France SAS

TABLE OF CONTENTS

PRODUCT SPECIFICATION	1
TABLE OF CONTENTS	2
1 PART NUMBERING SYSTEM	4
2 MAIN FEATURES	6
3 MECHANICAL SPECIFICATION	7
3.1 MECHANICAL CHARACTERISTICS	7
3.2 MECHANICAL DRAWING.....	8
4 ELECTRICAL SPECIFICATION	9
4.1 ABSOLUTE MAXIMUM RATINGS	9
4.2 ELECTRICAL CHARACTERISTICS	9
4.3 INTERFACE PIN ASSIGNMENT.....	10
4.4 INTERFACE BLOCK DIAGRAM	11
4.5 DISPLAY CONTROL INSTRUCTION.....	12
5 OPTICAL SPECIFICATION	21
6 BACKLIGHT SPECIFICATION	23
6.1 LED BACKLIGHT CHARACTERISTICS	23
6.1.1 WHITE EDGE STANDARD LED BACKLIGHT CHARACTERISTICS	23
6.1.2 YELLOW GREEN STANDARD LED BACKLIGHT CHARACTERISTICS.....	23
6.1.3 BLUE STANDARD LED BACKLIGHT CHARACTERISTICS.....	23
6.1.4 AMBER STANDARD LED BACKLIGHT CHARACTERISTICS.....	23
6.2 EL BACKLIGHT CHARACTERISTICS.....	27
6.2.1 WHITE STANDARD EL BACKLIGHT CHARACTERISTICS	23
6.2.2 GREEN STANDARD EL BACKLIGHT CHARACTERISTICS.....	23
6.2.3 BLUE STANDARD EL BACKLIGHT CHARACTERISTICS	23
7 QUALITY ASSURANCE SPECIFICATION	27
7.1 CONFORMITY	27
7.2 DELIVERY ASSURANCE.....	27
7.2.1 Delivery inspection standards.....	27
7.2.2 Zone definition	28
7.2.3 Visual inspection	28
7.2.4 Standard of appearance inspection.....	29
8 RELIABILITY SPECIFICATION	31
9 HANDLING PRECAUTIONS	32

Densitron France SAS

REVISION RECORD

Rev.	Date	Page	Chapt.	Comment	ECR no.
1	01/08/08			Initial Specification	

Densitron France SAS

24, rue de l'Atlantique • ZA Pôle Sud • 44115 Basse-Goulaine • FRANCE • Tél : 02.51.71.01.58 • Fax : 02.51.71.34.52
Site Internet : www.densitron.com • Email : sales@densitron.fr
SA au capital de 400.000€ • RCS Nantes B352 414 429 • TVA : FR 44 352 414 429
A group company of Densitron Technologies plc

1 PART NUMBERING SYSTEM

LWM 2004A-B - BW - WCF *

Densitron low cost module ① ② ③ ④ ⑤ ⑥

① Characters x Row format

② Model serials number

③ Display mode and backlight type :

A = Reflective (without backlight) =

B* = Transflective positive LEDS array type backlight (BG, BA, BW, BR...)

B*(E) = Transflective LEDS edge type backlight (BGE, BAE, BWE, BR...)

B = Transflective CFL

C* = Transflective positive EL backlight (CB, CW)

D* = Transmissive negative EL backlight (DB, DW)

E = CFL

E* = Transmissive negative LEDS array type backlight (EG, EA, EW, ER...)

E*(E) = Transmissive negative LEDS edge type backlight (EGE, EAE, EWE, ERE...)

(* color LED or EL backlight = G/ yellow-green, A/ amber, W/ white, R/ red, B/blue, ...)

④ Temperature range and power supply

D = Standard temperature range; negative supply voltage required (0°C~+50°C)

S = Standard temperature range; on board negative voltage generator (0°C~+50°C)

H= Wide temperature range; negative supply voltage required (-20°C ~+70°C)

W= Wide temperature range; on board negative voltage generator (-20°C ~+70°C)

⑤ Fluid type and compensation circuit option

NY = STN yellow-green glass, without temperature compensation circuit

CY = STN yellow green glass, with temperature compensation circuit on board

NG = STN gray glass without temperature compensation circuit

CG = STN gray glass with temperature compensation circuit

NB = STN blue glass, without temperature compensation circuit

CB = STN blue glass with temperature compensation circuit

NF = FSTN black and white glass without temperature compensation circuit

CF = FSTN black and white glass with temperature circuit on board

Densitron France SAS

© Special code for customized features

Please refer to our commercial office

Remarks and definitions :

1°) Display mode and backlight type :

- Reflective polarizer, no backlight, usable only in good ambient light conditions.
- Transflective polarizer uses a background backlight and a mirror reflector, usable in all lighting conditions.
- Transmissive polarizer needs the backlight switched on continuously, usable mostly in low ambient light conditions
- EL (electro-luminescent), uniform brightness, short life time (8000 hours max), needs EL inverter, low current consumption, low thickness.
- LED (light emitting diode), uniform brightness, long lifetime (100 000 hours), doesn't need inverter, reliable in vibration and shock environment, different colours available.

Array version is a direct lighting type, available in standard form, uniform and good brightness on all the active area.

Edge version is an edge lighting type providing a low consumption backlight, has a low thickness and brightness.

- Positive mode has dark pixels on a light background
- Negative mode has light pixels in a dark background and is normally used only with a transmissive polarizer as it needs a backlight on to be visible.

2°) Fluid type :

- STN yellow green or gray LCD has a yellow green or gray background with dark blue pixels and offers a good contrast.
- FSTN LCD is to produce very high contrast with black and white pixels using a film polarizer

Densitron France SAS

2 MAIN FEATURES

ITEM	CONTENTS
Display Format	20 characters x 4 Lines
Overall Dimensions	98.0 x 60.0 x 13.6(MAX)
Viewing Area	77.0 x 25.2
LCD type	TN, STN, FSTN
Mode	Available in Reflective/Positive /Negative modes
Viewing Angle	6 0'clock
Duty	1/16
Driver IC	KS0066 or equivalent
Backlight type	None /EL/ LED
Backlight colour	Yellow Green / White / Amber/Red/Blue
DC/DC converter	None/Included
Operating temperature	-20°/+70°C
Storage temperature	-30°/+80°C

Densitron France SAS

24, rue de l'Atlantique • ZA Pôle Sud • 44115 Basse-Goulaine • FRANCE • Tél : 02.51.71.01.58 • Fax : 02.51.71.34.52
 Site Internet : www.densitron.com • Email : sales@densitron.fr
 SA au capital de 400.000€ • RCS Nantes B352 414 429 • TVA : FR 44 352 414 429
 A group company of Densitron Technologies plc

3 MECHANICAL SPECIFICATION

3.1 MECHANICAL CHARACTERISTICS

Item	Dimension	Unit
Number of Characters	20 characters x 4Lines	
Module dimension	98.0 x 60.0 x 13.6(MAX)LED	mm
	98.0 x 60.0 x 9.3(MAX)No BL or EL	
View area	77.0 x 25.2	mm
Active area	70.4 x 20.8	mm
Dot size	0.55 x 0.55	mm
Dot pitch	0.60 x 0.60	mm
Character size	2.95 x 4.75	mm
Character pitch	3.55 x 5.35	mm

Densitron France SAS

3.2 MECHANICAL DRAWING

Version LED, EL

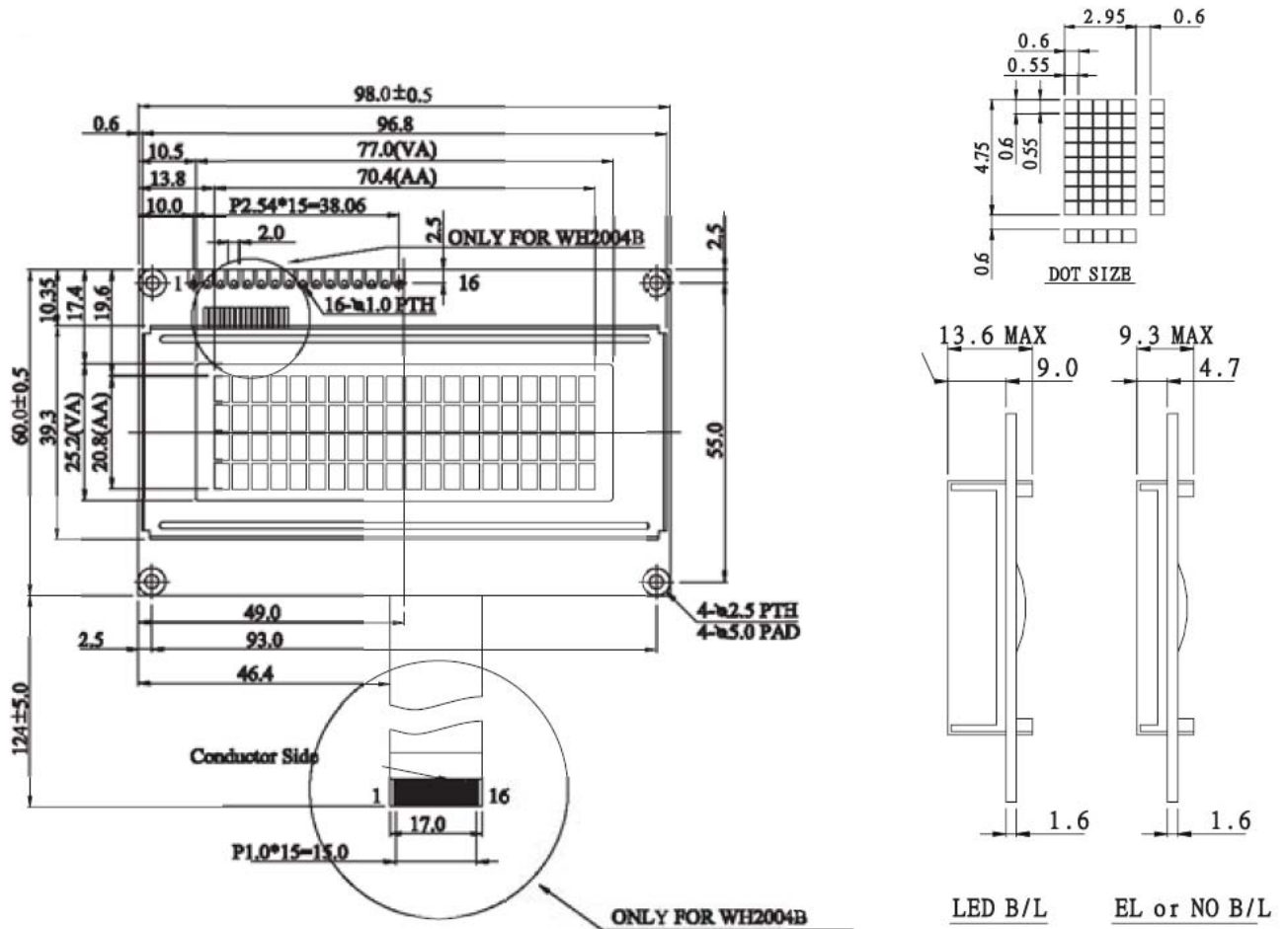

Densitron France SAS

24, rue de l'Atlantique • ZA Pôle Sud • 44115 Basse-Goulaine • FRANCE • Tél : 02.51.71.01.58 • Fax : 02.51.71.34.52
 Site Internet : www.densitron.com • Email : sales@densitron.fr
 SA au capital de 400.000€ • RCS Nantes B352 414 429 • TVA : FR 44 352 414 429
 A group company of Densitron Technologies plc

4 ELECTRICAL SPECIFICATION

4.1 ABSOLUTE MAXIMUM RATINGS

Item	Symbol	Min	Typ	Max	Unit
Operating Temperature	T _{OP}	-20	-	+70	°C
Storage Temperature	T _{ST}	-30	-	+80	°C
Input Voltage	V _I	V _{SS}	-	V _{DD}	V
Supply Voltage For Logic	V _{DD} -V _{SS}	-0.3	□	7	V
Supply Voltage For LCD	V _{DD} -V ₀	-0.3	-	13	V

Note 1: Background colour changes slightly depending on ambient temperature. This phenomenon is reversible. Ta≤70 °C:
75% RH max

Note 2: Ta≤80 °C: 75% RH max

4.2 ELECTRICAL CHARACTERISTICS

Item	Symbol	Condition	Min	Typ	Max	Unit
Supply Voltage For Logic	V _{DD} -V _{SS}	-	4.5	5.0	5.5	V
Supply Voltage For LCD	V _{DD} -V ₀	Ta=-20°C	-	-	5.3	V
		Ta=25°C	-	4.5	-	V
		Ta=70°C	3.8	-	-	V
Input High Volt.	V _{IH}	-	0.7 V _{DD}	-	V _{DD}	V
Input Low Volt.	V _{IL}	-	V _{SS}	-	0.6	V
Output High Volt.	V _{OH}	-	3.9	-	-	V
Output Low Volt.	V _{OL}	-	-	-	0.4	V
Supply Current	I _{DD}	V _{DD} =5.0V	1.0	1.2	1.5	mA

V_{SS} = 0 V, Ta = 25 °C

* I_{DD} measurement condition is for all pattern ON

Densitron France SAS

4.3 INTERFACE PIN ASSIGNMENT

Pin No.	Symbol	Level	Description
1	V _{SS}	0V	Ground
2	V _{DD}	5.0V	Supply Voltage for logic
3	VO	(Variable)	Operating voltage for LCD
4	RS	H/L	H: DATA, L: Instruction code
5	R/W	H/L	H: Read(MPU→Module) L: Write(MPU→Module)
6	E	H,H→L	Chip enable signal
7	DB0	H/L	Data bus line
8	DB1	H/L	Data bus line
9	DB2	H/L	Data bus line
10	DB3	H/L	Data bus line
11	DB4	H/L	Data bus line
12	DB5	H/L	Data bus line
13	DB6	H/L	Data bus line
14	DB7	H/L	Data bus line
15	A	-	LED +
16	K	-	LED -

Densitron France SAS

4.4 Interface Block Diagram

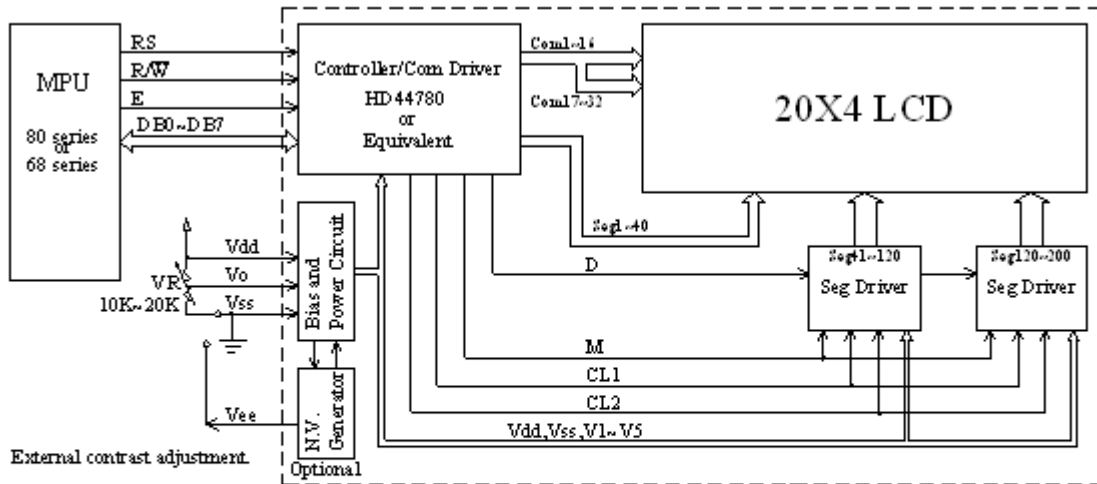

Character located	1	2	3	4	5	6	7	8	9	10	11	12	13	14	15	16	17	18	19	20
DDRAM address	00	01	02	03	04	05	06	07	08	09	0A	0B	0C	0D	0E	0F	10	11	12	13
DDRAM address	40	41	42	43	44	45	46	47	48	49	4A	4B	4C	4D	4E	4F	50	51	52	53
DDRAM address	14	15	16	17	18	19	1A	1B	1C	1D	1E	1F	20	21	22	23	24	25	26	27
DDRAM address	54	55	56	57	58	59	5A	5B	5C	5D	5E	5F	60	61	62	63	64	65	66	67

Densitron France SAS

24, rue de l'Atlantique • ZA Pôle Sud • 44115 Basse-Goulaine • FRANCE • Tél : 02.51.71.01.58 • Fax : 02.51.71.34.52
 Site Internet : www.densitron.com • Email : sales@densitron.fr
 SA au capital de 400.000€ • RCS Nantes B352 414 429 • TVA : FR 44 352 414 429
 A group company of Densitron Technologies plc

4.5 DISPLAY CONTROL INSTRUCTION

The LCD display Module has a built-in LSI controller, the controller has two 8-bit registers, an instruction register (IR) and a data register (DR).

The IR stores instruction codes, such as display clear and cursor shift, and address information for display data RAM (DDRAM) and character generator (CGRAM). The IR can only be written from the MPU.

The DR temporarily stores data to be written or read from DDRAM or CGRAM. When address information is written into the IR, then data is stored into the DR from DDRAM or CGRAM. By the register selector (RS) signal, these two registers can be selected.

RS	R/W	Operation
0	0	IR write as an internal operation (display clear, etc.)
0	1	Read busy flag (DB7) and address counter (DB0 to DB7)
1	0	Write data to DDRAM or CGRAM (DR to DDRAM or CGRAM)
1	1	Read data from DDRAM or CGRAM (DDRAM or CGRAM to DR)

Busy Flag (BF)

When the busy flag is 1, the controller LSI is in the internal operation mode, and the next instruction will not be accepted. When RS=0 and R/W=1, the busy flag is output to DB7. The next instruction must be written after ensuring that the busy flag is 0.

Address Counter (AC)

The address counter (AC) assigns addresses to both DDRAM and CGRAM

Display Data RAM (DDRAM)

This DDRAM is used to store the display data represented in 8-bit character codes. Its extended capacity is 80×8 bits or 80 characters. Below figure is the relationship between DDRAM addresses and positions on the liquid crystal display.

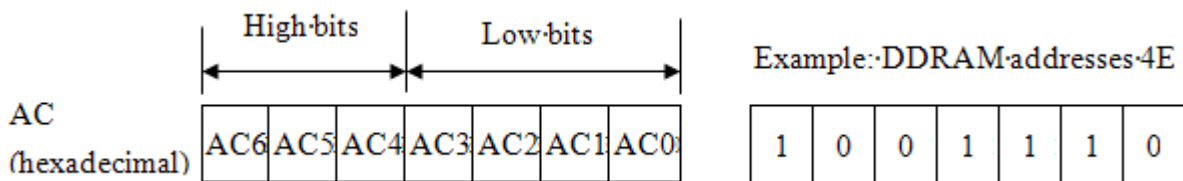

Densitron France SAS

Display position DDRAM address

1 2 3 4 5 6 7 8 9 10 11 12 13 14 15 16 17 18 19 20

00	01	02	03	04	05	06	07	08	09	0A	0B	0C	0D	0E	0F	10	11	12	13
40	41	42	43	44	45	46	47	48	49	4A	4B	4C	4D	4E	4F	50	51	52	53
14	15	16	17	18	19	1A	1B	1C	1D	1E	1F	20	21	22	23	24	25	26	27
54	55	56	57	58	59	5A	5B	5C	5D	5E	5F	60	61	62	63	64	65	66	67

4-Line by 20-Character Display

Character Generator RAM (CGRAM)

In CGRAM, the user can rewrite character by program. For 5×8 dots, eight character patterns can be written, and for 5×10 dots, four character patterns can be written.

Write into DDRAM the character code at the addresses shown as the left column of table 1. To show the character patterns stored in CGRAM.

Densitron France SAS

Relationship between CGRAM Addresses, Character Codes (DDRAM) and Character patterns

Table 1.

For 5 * 8 dot character patterns

Character Codes (DDRAM data)		CGRAM Address		Character Patterns (CGRAM data)		
7 6 5 4 3 2 1 0		5 4 3 2 1 0		7 6 5 4 3 2 1 0		
High Low		High Low		High Low		
0 0 0 0 * 0 0 0		0 0 0	0 0 0	* * *	0	Character pattern(1)
			0 0 1	* * *	0 0 0	
			0 1 0	* * *	0 0 0	
			0 1 1	* * *	0	
			1 0 0	* * *	0 0 0	
			1 0 1	* * *	0 0 0	
			1 1 0	* * *	0 0 0	
			1 1 1	* * *	0 0 0 0 0	
			0 0 0	* * *	0 0 0 0	
			0 0 1	* * *	0 0 0 0	
0 1 0	* * *	0 0 0 0				
0 1 1	* * *	0 0 0 0				
1 0 0	* * *	0 0 0 0				
1 0 1	* * *	0 0 0 0				
1 1 0	* * *	0 0 0 0				
1 1 1	* * *	0 0 0 0				
0 0 0	* * *	0 0 0 0				
0 0 1	* * *	0 0 0 0				
0 0 0 0 * 0 0 1	0 0 1	0 0 0	* * *	0	Character pattern(2)	
0 0 0 0 * 0 0 1	0 0 1	0 0 1	* * *	0 0 0 0		
0 0 0 0 * 0 0 1	0 0 1	1 0 0	* * *	0 0 0 0		
0 0 0 0 * 0 0 1	0 0 1	1 0 1	* * *	0 0 0 0		
0 0 0 0 * 0 0 1	0 0 1	1 1 0	* * *	0 0 0 0		
0 0 0 0 * 0 0 1	0 0 1	1 1 1	* * *	0 0 0 0		
0 0 0 0 * 0 0 1	0 0 1	0 0 0	* * *	0 0 0 0		
0 0 0 0 * 0 0 1	0 0 1	0 0 1	* * *	0 0 0 0		
0 0 0 0 * 0 0 1	0 0 1	0 1 0	* * *	0 0 0 0		
0 0 0 0 * 0 0 1	0 0 1	0 1 1	* * *	0 0 0 0		
0 0 0 0 * 1 1 1	1 1 1	1 0 0	* * *	0	Cursor pattern	
0 0 0 0 * 1 1 1	1 1 1	1 0 1	* * *	0		
0 0 0 0 * 1 1 1	1 1 1	1 1 0	* * *	0		
0 0 0 0 * 1 1 1	1 1 1	1 1 1	* * *	0		

For 5 * 10 dot character patterns

Character Codes (DDRAM data)		CGRAM Address		Character Patterns (CGRAM data)		
7 6 5 4 3 2 1 0		5 4 3 2 1 0		7 6 5 4 3 2 1 0		
High Low		High Low		High Low		
0 0 0 0 * 0 0 0		0 0	0 0 0 0	* * *	0 0 0 0 0	Character pattern
			0 0 0 1	* * *	0 0 0 0 0	
			0 0 1 0	* * *	0 0 0 0 0	
			0 0 1 1	* * *	0 0 0 0 0	
			0 1 0 0	* * *	0 0 0 0 0	
			0 1 0 1	* * *	0 0 0 0 0	
			0 1 1 0	* * *	0 0 0 0 0	
			0 1 1 1	* * *	0 0 0 0 0	
			1 0 0 0	* * *	0 0 0 0 0	
			1 0 0 1	* * *	0 0 0 0 0	
1 0 1 0	* * *	0 0 0 0 0	Cursor pattern			
1 0 1 0	* * *	0 0 0 0 0				
1 1 1 1	* * *	0 0 0 0 0				
1 1 1 1	* * *	0 0 0 0 0				
1 1 1 1	* * *	0 0 0 0 0				
1 1 1 1	* * *	0 0 0 0 0				
1 1 1 1	* * *	0 0 0 0 0				
1 1 1 1	* * *	0 0 0 0 0				
1 1 1 1	* * *	0 0 0 0 0				
1 1 1 1	* * *	0 0 0 0 0				

■ : " High "

Character Generator ROM Pattern Table 2.

Upper 4 bit Lower 4 bit	LLLL	LLLH	LLHL	LLHH	LHLL	LHLH	LHHL	LHHH	HLLL	HLLH	HLHL	HLHH	HHLL	HHLH	HHHL	HHHH
LLLL	CG RAM (1)			0	1	2	3	4				5	6	7	8	9
LLLH	(2)	:	;	!	@	#	\$	%			^	_	~	+	=	-
LLHL	(3)	"	'	()	[]	{				~	^	_	~	^
LLHH	(4)	*	~	^	_	~	^	_			^	_	~	^	_	~
LHLL	(5)	\$	%	&	'	()	*			^	_	~	^	_	~
LHLH	(6)	~	^	_	~	^	_	~			^	_	~	^	_	~
LHHL	(7)	0	1	2	3	4	5	6			^	_	~	^	_	~
LHHH	(8)	7	8	9	:	;	!	@			^	_	~	^	_	~
HLLL	(1)	C	E	H	N	X					^	_	~	^	_	~
HLLH	(2)	S	I	V	I	V					^	_	~	^	_	~
HLHL	(3)	*	~	^	_	~	^	_			^	_	~	^	_	~
HLHH	(4)	+	=	-	~	^	_	~			^	_	~	^	_	~
HHLL	(5)	.	<	L	~	^	_	~			^	_	~	^	_	~
HHLH	(6)	-	~	^	_	~	^	_			^	_	~	^	_	~
HHHL	(7)	.	~	^	_	~	^	_			^	_	~	^	_	~
HHHH	(8)	/	~	^	_	~	^	_			^	_	~	^	_	~

Densitron France SAS

24, rue de l'Atlantique • ZA Pôle Sud • 44115 Basse-Goulaine • FRANCE • Tél : 02.51.71.01.58 • Fax : 02.51.71.34.52
 Site Internet : www.densitron.com • Email : sales@densitron.fr
 SA au capital de 400.000€ • RCS Nantes B352 414 429 • TVA : FR 44 352 414 429
 A group company of Densitron Technologies plc

Instruction Table

Instruction	Instruction Code										Description	Execution time (fosc=270Khz)	
	RS	R/W	DB7	DB6	DB5	DB4	DB3	DB2	DB1	DB0			
Clear Display	0	0	0	0	0	0	0	0	0	0	1	Write "00H" to DDRAM and set DDRAM address to "00H" from AC	1.53ms
Return Home	0	0	0	0	0	0	0	0	0	1	-	Set DDRAM address to "00H" from AC and return cursor to its original position if shifted. The contents of DDRAM are not changed.	1.53ms
Entry Mode Set	0	0	0	0	0	0	0	0	1	I/D	SH	Assign cursor moving direction and enable the shift of entire display.	39µs
Display ON/OFF Control	0	0	0	0	0	0	0	1	D	C	B	Set display (D), cursor (C), and blinking of cursor (B) on/off control bit.	39µs
Cursor or Display Shift	0	0	0	0	0	0	1	S/C	R/L	-	-	Set cursor moving and display shift control bit, and the direction, without changing of DDRAM data.	39µs
Function Set	0	0	0	0	1	DL	N	F	-	-	-	Set interface data length (DL:8-bit/4-bit), numbers of display line (N:2-line/1-line)and, display font type (F:5×11 dots/5×8 dots)	39µs
Set CGRAM Address	0	0	0	1	AC5	AC4	AC3	AC2	AC1	AC0		Set CGRAM address in address counter.	39µs
Set DDRAM Address	0	0	1	AC6	AC5	AC4	AC3	AC2	AC1	AC0		Set DDRAM address in address counter.	39µs
Read Busy Flag and Address	0	1	BF	AC6	AC5	AC4	AC3	AC2	AC1	AC0		Whether during internal operation or not can be known by reading BF. The contents of address counter can also be read.	0µs
Write Data to RAM	1	0	D7	D6	D5	D4	D3	D2	D1	D0		Write data into internal RAM (DDRAM/CGRAM).	43µs
Read Data from RAM	1	1	D7	D6	D5	D4	D3	D2	D1	D0		Read data from internal RAM (DDRAM/CGRAM).	43µs

* " - " : don't care

Densitron France SAS

24, rue de l'Atlantique • ZA Pôle Sud • 44115 Basse-Goulaine • FRANCE • Tél : 02.51.71.01.58 • Fax : 02.51.71.34.52
 Site Internet : www.densitron.com • Email : sales@densitron.fr
 SA au capital de 400.000€ • RCS Nantes B352 414 429 • TVA : FR 44 352 414 429
 A group company of Densitron Technologies plc

Timing Characteristics

Write Operation

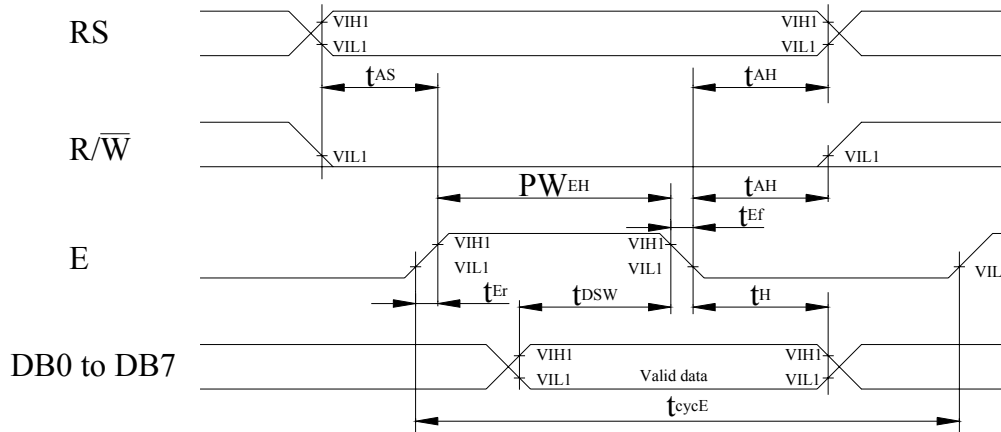

Ta=25°C, VDD=5.0± 0.5V

Item	Symbol	Min	Typ	Max	Unit
Enable cycle time	t_{cycE}	400	-	-	ns
Enable pulse width (high level)	PW_{EH}	150	-	-	ns
Enable rise/fall time	t_{Er}, t_{Erf}	-	-	25	ns
Address set-up time (RS, R/W to E)	t_{AS}	30	-	-	ns
Address hold time	t_{AH}	10	-	-	ns
Data set-up time	t_{Dsw}	40	-	-	ns
Data hold time	t_H	10	-	-	ns

Densitron France SAS

24, rue de l'Atlantique • ZA Pôle Sud • 44115 Basse-Goulaine • FRANCE • Tél : 02.51.71.01.58 • Fax : 02.51.71.34.52
 Site Internet : www.densitron.com • Email : sales@densitron.fr
 SA au capital de 400.000€ • RCS Nantes B352 414 429 • TVA : FR 44 352 414 429
 A group company of Densitron Technologies plc

Read Operation

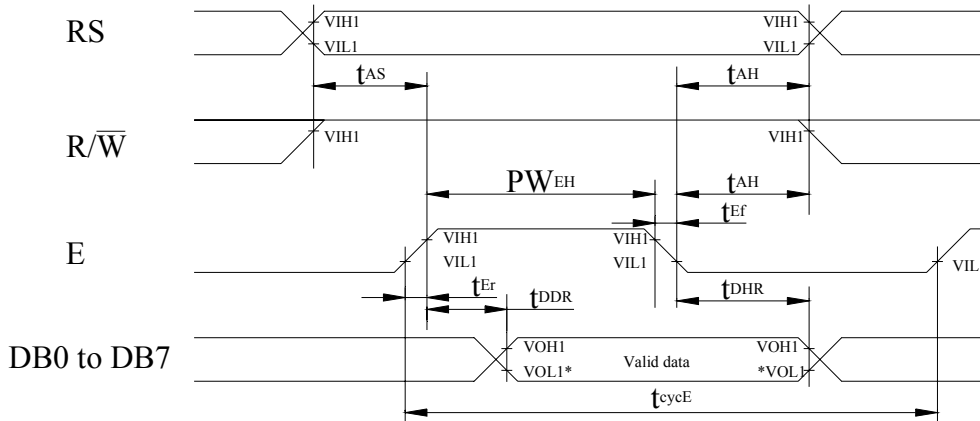

NOTE: *VOL1 is assumed to be 0.8V at 2 MHz operation.

Ta=25°C, VDD=5.0± 0.5V

Item	Symbol	Min	Typ	Max	Unit
Enable cycle time	t _{cycE}	400	-	-	ns
Enable pulse width (high level)	PW _{EH}	150	-	-	ns
Enable rise/fall time	t _{Er} , t _{Ef}	-	-	25	ns
Address set-up time (RS, R/W to E)	t _{AS}	30	-	-	ns
Address hold time	t _{AH}	10	-	-	ns
Data delay time	t _{DDR}	-	-	100	ns
Data hold time	t _{DHR}	20	-	-	ns

Densitron France SAS

24, rue de l'Atlantique • ZA Pôle Sud • 44115 Basse-Goulaine • FRANCE • Tél : 02.51.71.01.58 • Fax : 02.51.71.34.52
 Site Internet : www.densitron.com • Email : sales@densitron.fr
 SA au capital de 400.000€ • RCS Nantes B352 414 429 • TVA : FR 44 352 414 429
 A group company of Densitron Technologies plc

Initializing of LCM

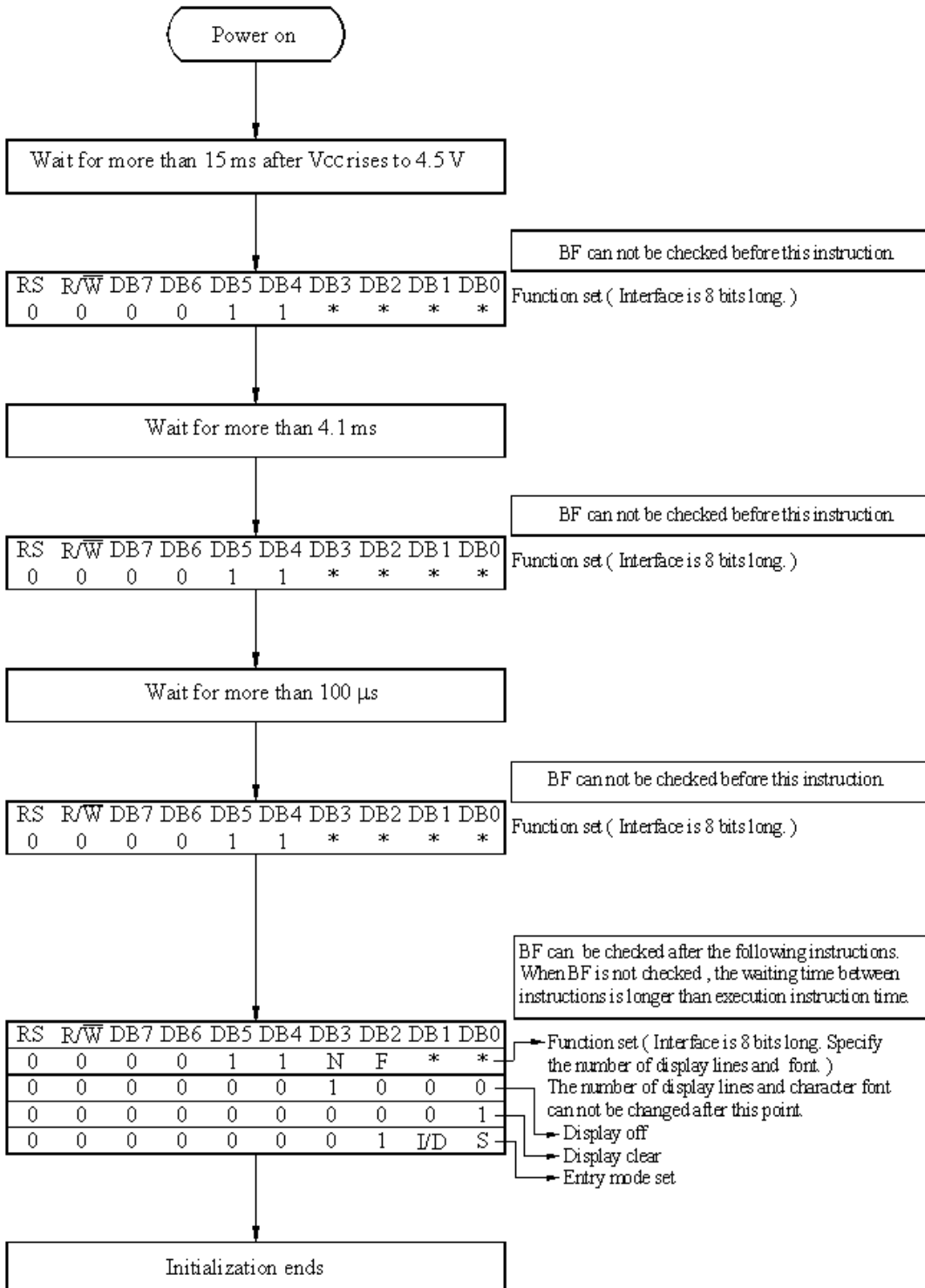

8-Bit Interface

Densitron France SAS

24, rue de l'Atlantique • ZA Pôle Sud • 44115 Basse-Goulaine • FRANCE • Tél : 02.51.71.01.58 • Fax : 02.51.71.34.52
 Site Internet : www.densitron.com • Email : sales@densitron.fr
 SA au capital de 400.000€ • RCS Nantes B352 414 429 • TVA : FR 44 352 414 429
 A group company of Densitron Technologies plc

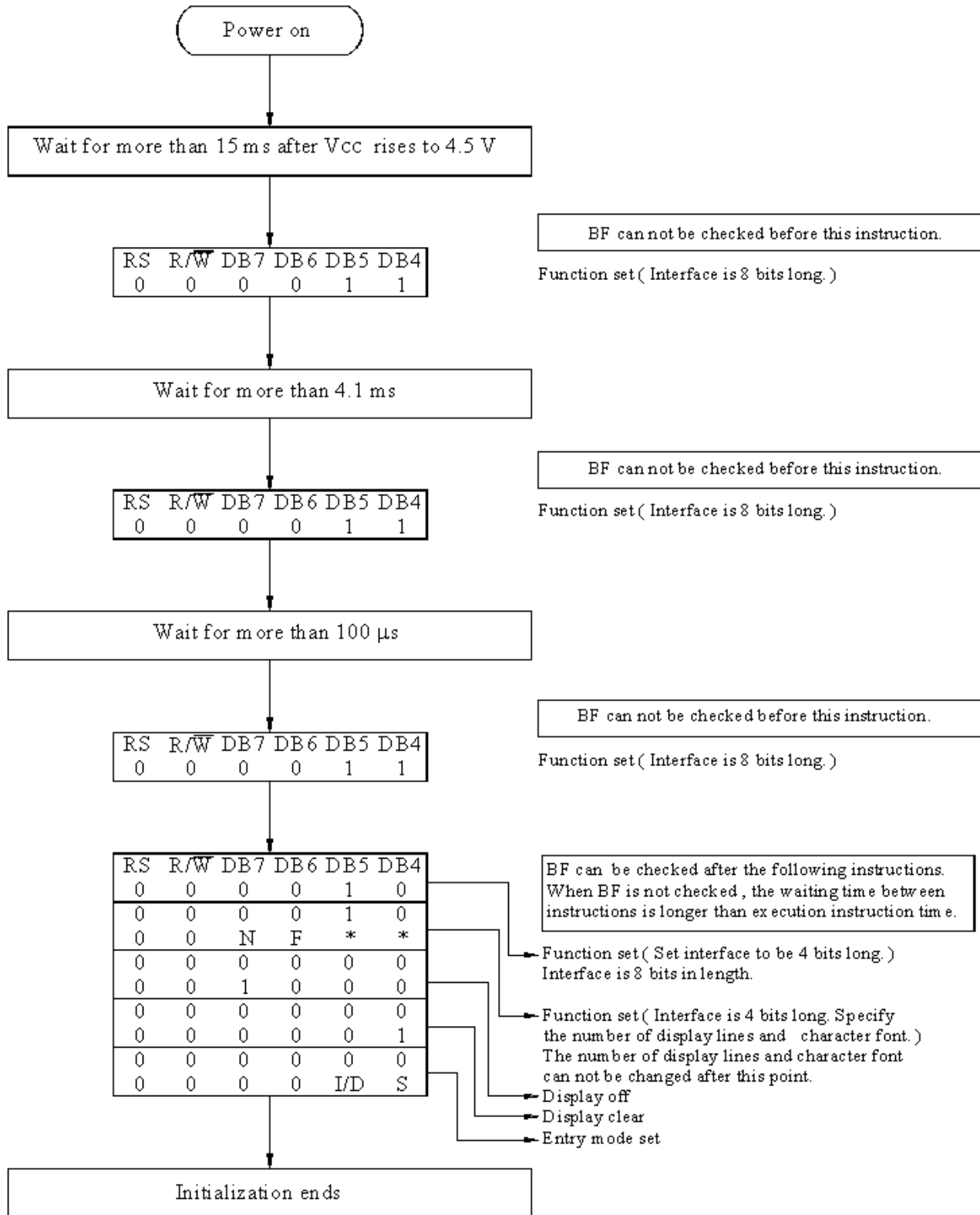

4-Bit Interface

Densitron France SAS

5 OPTICAL SPECIFICATION (TN and STN Characteristics).

TN_Item	Symbol	Condition	Min	Typ	Max	Unit
View Angle	(V) θ	$CR \geq 2$	10	-	30	deg
	(H) ϕ	$CR \geq 2$	-15	-	15	deg
Contrast Ratio	CR	-	-	2	-	-
Response Time	T rise	-	-	100	150	ms
	T fall	-	-	100	150	ms

STN_Item	Symbol	Condition	Min	Typ	Max	Unit
View Angle	(V) θ	$CR \geq 2$	10	-	105	deg
	(H) ϕ	$CR \geq 2$	-30	-	30	deg
Contrast Ratio	CR	-	-	3	-	-
Response Time	T rise	-	-	200	300	ms
	T fall	-	-	200	300	ms

Note 1: definition of viewing angle θ_1 & θ_2

Note 2: definition of viewing angle θ_3 & θ_4

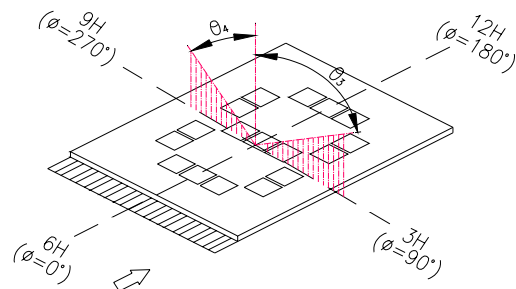
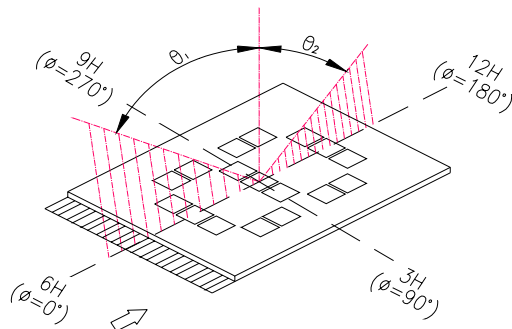

Densitron France SAS

Note 3: definition of contrast ratio (CR)

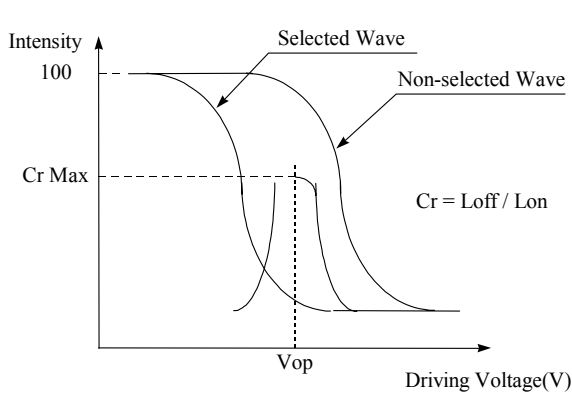

[positive type]

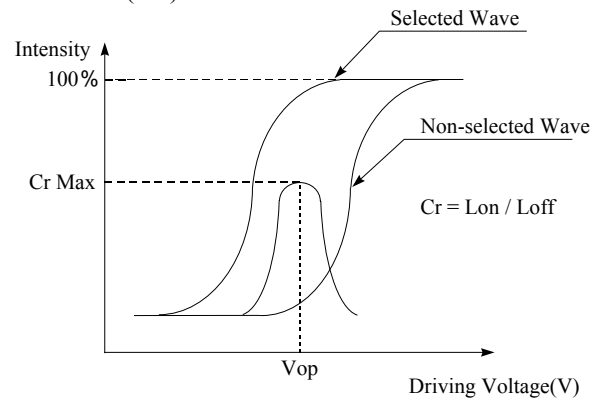

[Negative type]

Note 4: definition of response time

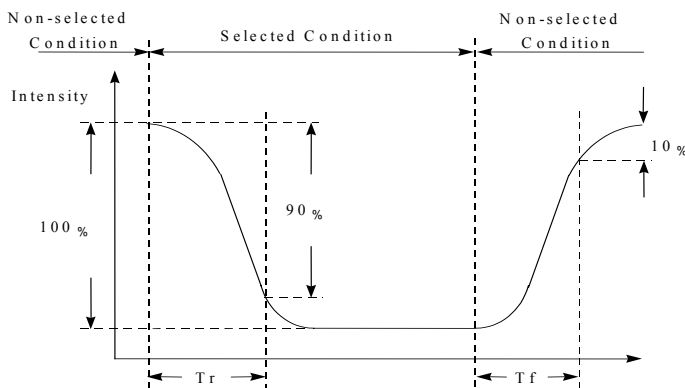

[positive type]

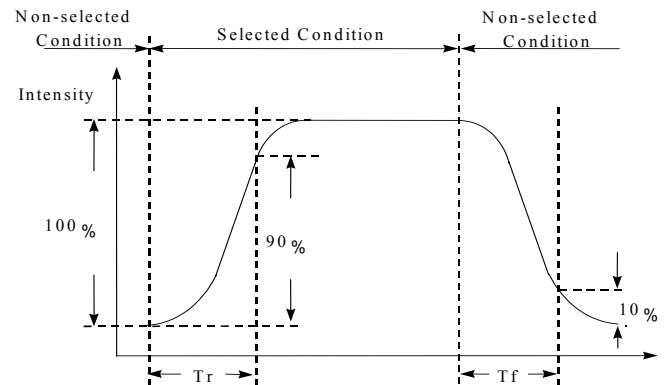

[Negative type]

Densitron France SAS

6 BACKLIGHT SPECIFICATION

6.1 LED BACKLIGHT CHARACTERISTICS

6.1.1 WHITE EDGE LED BACKLIGHT CHARACTERISTICS

PARAMETER	SYMBOL	MIN	TYP	MAX	UNIT	TEST CONDITION
Supply Current	I _{LED}	48	60	90	mA	V=3.5V
Supply Voltage	V	3.4	3.5	3.6	V	-
Reverse Voltage	V _R	-	-	8	V	-
Luminous Intensity	I _V	20	-	-	CD/M ²	I _{LED} =60mA
Wave Length	λ _p	-	-	-	nm	I _{LED} =60mA
Life Time	-	-	50K	-	Hr.	I _{LED} =60mA
Color	White					

6.1.2 YELLOW GREEN STANDARD LED BACKLIGHT CHARACTERISTICS

PARAMETER	SYMBOL	MIN	TYP	MAX	UNIT	TEST CONDITION
Supply Current	I _{LED}	224	280	420	mA	V=4.2V
Supply Voltage	V	4.0	4.2	4.4	V	-
Reverse Voltage	V _R	-	-	10	V	-
Luminous Intensity	I _V	-	180	-	CD/M ²	I _{LED} =280mA
Wave Length	λ _p	-	570	-	nm	I _{LED} =280mA
Life Time	-	-	100000	-	Hr.	I _{LED} ≤280mA
Color	Yellow Green					

Densitron France SAS

6.1.3 BLUE STANDARD LED BACKLIGHT CHARACTERISTICS

PARAMETER	SYMBOL	MIN	TYP	MAX	UNIT	TEST CONDITION
Supply Current	I _{LED}	—	60	—	mA	V=3.5V
Supply Voltage	V	-	3.5	3.7	V	-
Reverse Voltage	V _R	-	-	8	V	-
Luminous Intensity	I _V	20	-	-	CD/M ²	I _{LED} =60mA
Wave Length	λ _p	—	470	-	nm	I _{LED} =60mA
Life Time	-	-	10000	-	Hr.	V≤3.5V
Color	Blue					

6.1.4 AMBER STANDARD LED BACKLIGHT CHARACTERISTICS

PARAMETER	SYMBOL	MIN	TYP	MAX	UNIT	TEST CONDITION
Supply Current	I _{LED}	—	280	560	mA	V=3.9V
Supply Voltage	V	-	3.9	4.2	V	-
Reverse Voltage	V _R	-	-	10	V	-
Luminous Intensity	I _V	-	180	-	CD/M ²	I _{LED} =280mA
Wave Length	λ _p	—	595	-	nm	I _{LED} =280mA
Life Time	-	-	100000	-	Hr.	V≤3.9V
Color	Amber					

Densitron France SAS

6.2 1 EL BACKLIGHT CHARACTERISTICS

6.2 1 EL WHITE BACKLIGHT CHARACTERISTICS

PARAMETER	SYMBOL	MIN	TYP	MAX	UNIT	TEST CONDITION
Drive Voltage	Vmax	—	110	170	Vrms	25° C
Drive Wave	Fmax	-	400	1000	Hz	25° C
Brightness		20	-	-	cd/m ²	110V/400Hz
Power Consumption		-	48.5	-	mW	110V/400Hz
Chromatism	X	-	0.3019	-	-	110V/400Hz
	Y	-	0.3929	-	-	110V/400Hz
Life time		5000			hour	110V/400Hz
Color		White			-	Light on 110V/400Hz

6.22 EL GREEN BACKLIGHT CHARACTERISTICS

PARAMETER	SYMBOL	MIN	TYP	MAX	UNIT	TEST CONDITION
Drive Voltage	Vmax	—	110	170	Vrms	25° C
Drive Wave	Fmax	-	400	1000	Hz	25° C
Brightness	-	48	60	-	cd/m²	110V/400Hz
Power Consumption	-	-	80	-	mW	110V/400Hz
Chromatism	X	-	0.182	-	-	110V/400Hz
	Y	-	0.460	-	-	
Life time	-	5000hrs				110V/400Hz
Color	-	Green				Light on 110V/400Hz

Densitron France SAS

6.2.3 EL BLUE BACKLIGHT CHARACTERISTICS

PARAMETER	SYMBOL	MIN	TYP	MAX	UNIT	TEST CONDITION
Drive Voltage	Vmax	—	110	170	Vrms	25° C
Drive Wave	Fmax	-	400	1000	Hz	25° C
Brightness		20	-	-	cd/m ²	110V/400Hz
Power Consumption		-	48.5	-	mW	110V/400Hz
Chromatism	X	-	0.180	-	-	110V/400Hz
	Y	-	0.398	-	-	110V/400Hz
Life time		5000			hour	110V/400Hz
Color		Blue			-	Light on 110V/400Hz

Densitron France SAS

24, rue de l'Atlantique • ZA Pôle Sud • 44115 Basse-Goulaine • FRANCE • Tél : 02.51.71.01.58 • Fax : 02.51.71.34.52
 Site Internet : www.densitron.com • Email : sales@densitron.fr
 SA au capital de 400.000€ • RCS Nantes B352 414 429 • TVA : FR 44 352 414 429
 A group company of Densitron Technologies plc

7. QUALITY ASSURANCE SPECIFICATION

7.1 CONFORMITY

The performance, function and reliability of the shipped products conform to the Product Specification.

7.2 DELIVERY ASSURANCE

7.2.1 Delivery inspection standards.

- MIL-STD-105E, general inspection level II, single sampling level;
- IPC-AA610 rev. C, class 2 electronic assemblies standard

The quality assurance levels are shown below:

Rank	Item Inspected	Defect type	AQL	Remark
Critical defect	Display	Non display	0.65%	Display malfunction
		Over current		
		Missing segment		
		Wrong viewing direction		
		Backlight OFF		
	Dimension	PCB and bezel out of specification	0.65%	Assembly failure
Major defect	Display	Incorrect operating	1.0%	
	Backlight	Flashing, dust		
		Wrong colour		
Minor defect	LCD	Black and white spot	2.5%	Appearance defect
		Black and white lines		
		Polariser scratch		
		Bubbles in polariser		
		Segment deformation, pin hole		
		Colour uniformity		
		Glass chip		
	COB	Wire bond pad exposed		
		Insufficient covering with resin (wire bond line exposed)		
		Bubble, dust on COB		
	PCB	Dust, solder ball on PCB		
Pad scratch				
Total			2.5%	

Densitron France SAS

7.2.2 Zone definition

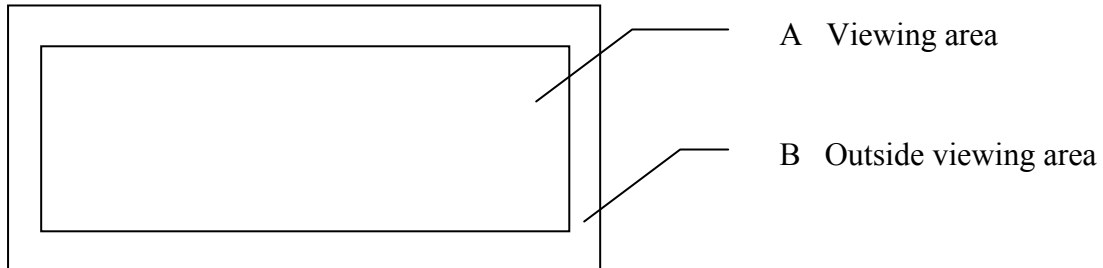

7.2.3 Visual inspection

- Inspect under 2x20W or 40W fluorescent lamp (approximately 3000 lux) leaving 25 to 30 cm between the module and the lamp and 30 cm between the module and the eye (measuring position).
- Appearance is inspected at the best contrast voltage (best contrast is adjusted considering clearness and crosstalk on screen).
- Inspect the module at 45° right and left, top and bottom.
- Use the optimum viewing angle during the contrast inspection.

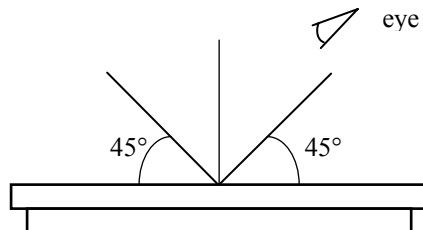

Densitron France SAS

7.2.4 Standard of appearance inspection

Units: mm

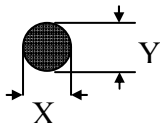
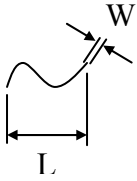
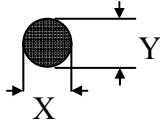
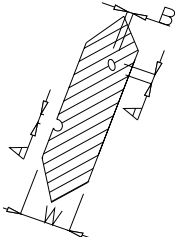
No	Item	Criteria																																			
1	Black spot, white spot, dust	<p>Round type: as per following drawing $\varnothing = (X+Y)/2$</p>  <table border="1" style="margin-left: 200px;"> <thead> <tr> <th colspan="3">Acceptable quantity</th> </tr> <tr> <th>Size</th> <th>Zone A</th> <th>Zone B</th> </tr> </thead> <tbody> <tr> <td>$\varnothing < 0.1$</td> <td>Any number</td> <td rowspan="4">Any number</td> </tr> <tr> <td>$0.1 < \varnothing < 0.2$</td> <td>6</td> </tr> <tr> <td>$0.2 < \varnothing < 0.3$</td> <td>2</td> </tr> <tr> <td>$0.3 < \varnothing$</td> <td>0</td> </tr> </tbody> </table> <p>Line type: as per following drawing</p>  <table border="1" style="margin-left: 200px;"> <thead> <tr> <th colspan="4">Acceptable quantity</th> </tr> <tr> <th>Length</th> <th>Width</th> <th>Zone A</th> <th>Zone B</th> </tr> </thead> <tbody> <tr> <td>--</td> <td>$W \leq 0.02$</td> <td>Any number</td> <td rowspan="4">Any number</td> </tr> <tr> <td>$L \leq 3.0$</td> <td>$0.02 < W \leq 0.03$</td> <td rowspan="2">2</td> </tr> <tr> <td>$L \leq 2.5$</td> <td>$0.03 < W \leq 0.05$</td> </tr> <tr> <td>--</td> <td>$0.05 < W$</td> <td>As round type</td> </tr> </tbody> </table> <p style="text-align: center;">Total acceptable quantity: 3</p>	Acceptable quantity			Size	Zone A	Zone B	$\varnothing < 0.1$	Any number	Any number	$0.1 < \varnothing < 0.2$	6	$0.2 < \varnothing < 0.3$	2	$0.3 < \varnothing$	0	Acceptable quantity				Length	Width	Zone A	Zone B	--	$W \leq 0.02$	Any number	Any number	$L \leq 3.0$	$0.02 < W \leq 0.03$	2	$L \leq 2.5$	$0.03 < W \leq 0.05$	--	$0.05 < W$	As round type
Acceptable quantity																																					
Size	Zone A	Zone B																																			
$\varnothing < 0.1$	Any number	Any number																																			
$0.1 < \varnothing < 0.2$	6																																				
$0.2 < \varnothing < 0.3$	2																																				
$0.3 < \varnothing$	0																																				
Acceptable quantity																																					
Length	Width	Zone A	Zone B																																		
--	$W \leq 0.02$	Any number	Any number																																		
$L \leq 3.0$	$0.02 < W \leq 0.03$	2																																			
$L \leq 2.5$	$0.03 < W \leq 0.05$																																				
--	$0.05 < W$	As round type																																			
2	Polariser scratch	<p>Scratch on protective film is permitted Scratch on polariser: same as No. 1</p>																																			
3	Polariser bubble	<p>$\varnothing = (X+Y)/2$</p>  <table border="1" style="margin-left: 200px;"> <thead> <tr> <th colspan="3">Acceptable quantity</th> </tr> <tr> <th>Size</th> <th>Zone A</th> <th>Zone B</th> </tr> </thead> <tbody> <tr> <td>$\varnothing < 0.3$</td> <td>Any number</td> <td rowspan="4">Any number</td> </tr> <tr> <td>$0.3 < \varnothing < 1.0$</td> <td>3</td> </tr> <tr> <td>$1.0 < \varnothing < 1.5$</td> <td>1</td> </tr> <tr> <td>$1.5 < \varnothing$</td> <td>0</td> </tr> </tbody> </table> <p style="text-align: center;">Total acceptable quantity: 4</p>	Acceptable quantity			Size	Zone A	Zone B	$\varnothing < 0.3$	Any number	Any number	$0.3 < \varnothing < 1.0$	3	$1.0 < \varnothing < 1.5$	1	$1.5 < \varnothing$	0																				
Acceptable quantity																																					
Size	Zone A	Zone B																																			
$\varnothing < 0.3$	Any number	Any number																																			
$0.3 < \varnothing < 1.0$	3																																				
$1.0 < \varnothing < 1.5$	1																																				
$1.5 < \varnothing$	0																																				
4	Segment deformation	<p>1. a. Pin hole on segmented display</p> <p>W: segment width $\varnothing = (A+B)/2$</p>  <table border="1" style="margin-left: 200px;"> <thead> <tr> <th colspan="2">Acceptable quantity</th> </tr> <tr> <th>Width</th> <th>\varnothing</th> </tr> </thead> <tbody> <tr> <td>$W \leq 0.4$</td> <td>$\varnothing \leq 0.2$ and $\varnothing \leq 1/2W$</td> </tr> <tr> <td>$W > 0.4$</td> <td>$\varnothing \leq 0.25$ and $\varnothing \leq 1/3W$</td> </tr> </tbody> </table> <p style="text-align: center;">Total acceptable quantity: 1 defect per segment Pin holes with \varnothing under 0.10 mm are acceptable</p>	Acceptable quantity		Width	\varnothing	$W \leq 0.4$	$\varnothing \leq 0.2$ and $\varnothing \leq 1/2W$	$W > 0.4$	$\varnothing \leq 0.25$ and $\varnothing \leq 1/3W$																											
Acceptable quantity																																					
Width	\varnothing																																				
$W \leq 0.4$	$\varnothing \leq 0.2$ and $\varnothing \leq 1/2W$																																				
$W > 0.4$	$\varnothing \leq 0.25$ and $\varnothing \leq 1/3W$																																				

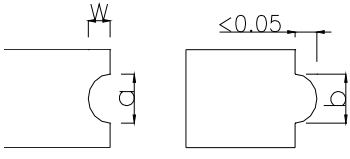
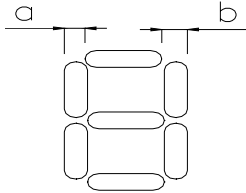
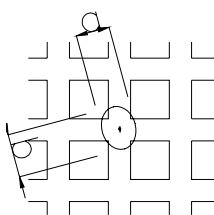
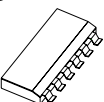
No	Item	Criteria																												
4	Segment deformation	<p>1b. Pin hole on dot matrix display</p> <div style="display: flex; align-items: center;">  <table border="1" style="margin-left: 20px;"> <thead> <tr> <th colspan="2">Acceptable quantity</th> </tr> <tr> <th>Size</th> <th></th> </tr> </thead> <tbody> <tr> <td>$a, b < 0.1$</td> <td>Any number</td> </tr> <tr> <td>$(a+b)/2 \le 0.1$</td> <td>Any number</td> </tr> <tr> <td>$0.5 < \varnothing < 1.0$</td> <td>3</td> </tr> </tbody> </table> <p style="text-align: right;">Total acceptable quantity: 7</p> <p>2. Segments / dots with different width</p> <div style="display: flex; align-items: center;">  <table border="1" style="margin-left: 20px;"> <thead> <tr> <th colspan="2">Acceptable</th> </tr> </thead> <tbody> <tr> <td>$a \geq b$</td> <td>$a/b \leq 4/3$</td> </tr> <tr> <td>$a < b$</td> <td>$a/b > 4/3$</td> </tr> </tbody> </table> </div> <p>3. Alignment layer defect $\varnothing = (a+b)/2$</p> <div style="display: flex; align-items: center;">  <table border="1" style="margin-left: 20px;"> <thead> <tr> <th colspan="2">Acceptable quantity</th> </tr> <tr> <th>Size</th> <th></th> </tr> </thead> <tbody> <tr> <td>$\varnothing \leq 0.4$</td> <td>Any number</td> </tr> <tr> <td>$0.4 < \varnothing \leq 1.0$</td> <td>5</td> </tr> <tr> <td>$1.0 < \varnothing \leq 1.5$</td> <td>3</td> </tr> <tr> <td>$1.5 < \varnothing \leq 2.0$</td> <td>2</td> </tr> </tbody> </table> <p style="text-align: right;">Total acceptable quantity: 7</p> </div> </div>	Acceptable quantity		Size		$a, b < 0.1$	Any number	$(a+b)/2 \le 0.1$	Any number	$0.5 < \varnothing < 1.0$	3	Acceptable		$a \geq b$	$a/b \leq 4/3$	$a < b$	$a/b > 4/3$	Acceptable quantity		Size		$\varnothing \leq 0.4$	Any number	$0.4 < \varnothing \leq 1.0$	5	$1.0 < \varnothing \leq 1.5$	3	$1.5 < \varnothing \leq 2.0$	2
Acceptable quantity																														
Size																														
$a, b < 0.1$	Any number																													
$(a+b)/2 \le 0.1$	Any number																													
$0.5 < \varnothing < 1.0$	3																													
Acceptable																														
$a \geq b$	$a/b \leq 4/3$																													
$a < b$	$a/b > 4/3$																													
Acceptable quantity																														
Size																														
$\varnothing \leq 0.4$	Any number																													
$0.4 < \varnothing \leq 1.0$	5																													
$1.0 < \varnothing \leq 1.5$	3																													
$1.5 < \varnothing \leq 2.0$	2																													
5	Colour uniformity	Level of sample for approval set as limit sample																												
6	Backlight	The backlight colour should correspond to the product specification Flashing and or unlit backlight is not allowed Dust larger than 0.25 mm is not allowed																												
7	COB	Exposed wire bond pad is not allowed Insufficient covering with resin is not allowed (wire bond line exposed) Dust or bubble on the resin are not allowed																												
8	PCB 	No unmelted solder paste should be present on PCB Cold solder joints, missing solder connections, or oxidation are not allowed No residue or solder balls on PCB are allowed Short circuits on components are not allowed																												

Densitron France SAS

8 RELIABILITY SPECIFICATION

Test Item	Test Condition	Description
High Temperature Operation	50°C or 70°C 200hrs	Endurance test applying the electric stress (Voltage & Current) and the thermal stress to the element for a long time.
Low Temperature Operation	0°C or -20°C 200hrs	Endurance test applying the electric stress under low temperature for a long time.
High Temperature Storage	70°C or 80°C 200hrs	Endurance test applying the high storage temperature for a long time.
Low Temperature Storage	-20°C or -30°C 200hrs	Endurance test applying the high storage temperature for a long time.
High Temperature & High Humidity Storage	80°C,90%RH 96hrs	Endurance test applying the high temperature and high humidity storage for a long time.
Thermal Shock Test	<p>←-30°C 25°C 80°C→ 30min 5min 30min For 10 cycles</p>	Endurance test applying the low and high temperature cycle. Burn In Test.
Vibration	10~22Hz→1.5mmp-p 22~500Hz→1.5G Total 0.5hrs	Endurance test applying the vibration during transportation and using.
ESD	VS=800V,RS=1.5kΩ CS=100pF	Endurance test applying the electric stress to the terminal.
Shock Test	50G Half sign wave 11 msdc 3 times of each direction	Constructional and mechanical endurance test applying the shock during transportation.

Densitron France SAS

9 HANDLING PRECAUTIONS

Safety

If the LCD panel breaks, be careful not to get the liquid crystal fluid in your mouth or in your eyes.
If the liquid crystal touches your skin or clothes, wash it off immediately using soap and plenty of water.

Mounting and Design

Place a transparent plate (e.g. acrylic, polycarbonate or glass) on the display surface to protect the display from external pressure. Leave a small gap between the transparent plate and the display surface.
When assembling with a zebra connector, clean the surface of the pads with alcohol and keep the surrounding air very clean.
Design the system so that no input signal is given unless the power supply voltage is applied.

Caution during LCD cleaning

Lightly wipe the display surface with a soft cloth soaked with Isopropyl alcohol, Ethyl alcohol or Trichlorotrifluoroethane.
Do not wipe the display surface with dry or hard materials that will damage the polariser surface.
Do not use aromatic solvents (toluene and xylene), or ketonic solvents (ketone and acetone).

Caution against static charge

As the display uses C-MOS LSI drivers, connect any unused input terminal to VDD or VSS. Do not input any signals before power is turned on.
Also, ground your body, work/assembly table and assembly equipment to protect against static electricity.

Packaging

Displays use LCD elements, and must be treated as such. Avoid strong shock and drop from a height.
To prevent displays from degradation, do not operate or store them exposed directly to sunshine or high temperature/humidity.

Caution during operation

It is indispensable to drive the display within the specified voltage limit since excessive voltage shortens its life.
Direct current causes an electrochemical reaction with remarkable deterioration of the display quality. Give careful consideration to prevent direct current during ON/OFF timing and during operation.
Response time is extremely delayed at temperatures lower than the operating temperature range while, at high temperatures, displays become dark. However, this phenomenon is reversible and does not mean a malfunction or a display that has been permanently damaged.
If the display area is pushed on hard during operation, some graphics will be abnormally displayed but returns to a normal condition after turning off the display once.
Even a small amount of condensation on the contact pads (terminals) can cause an electro-chemical reaction which causes missing rows and columns. Give careful attention to avoid condensation.

Storage

Store the display in a dark place where the temperature is 25°C ± 10°C and the humidity below 50%RH.
Store the display in a clean environment, free from dust, organic solvents and corrosive gases.
Do not crash, shake or jolt the display (including accessories).

Densitron France SAS