

* The specification subject to change without notice." "The drawing is for reference only.

R13-502

Screw Type

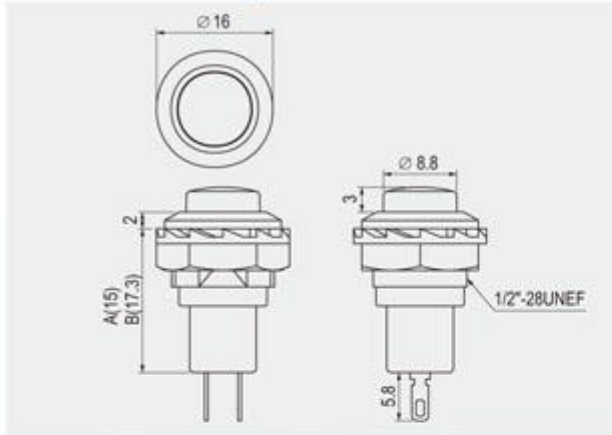

Rating
3A 125V AC 1.5A 250V AC
Contact resistance
50mΩ Max
Insulation resistance
DC 500V 100MΩ Min
Dielectric strength
AC 1000V 1 minute
Cut-out

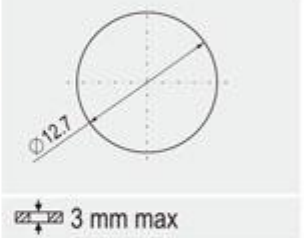

FEATURES

- * MATERIAL: Actuator and Frame are nylon (UL flame: 94V-2). Terminals are silver plated brass. Base is PBT.
- * M types are metal frames, nickel plated brass.
- * Mounted by nut.

R13-502

BODY	FUNCTION		TERMINAL
S Plastic Body 	A 2P SPST	C 3P SPDT (Only for R13-502MC) * () =momentary	0 5 SO
M Metal Body 	B 2P SPST		

