



APPROVAL SHEET

CUSTOMER NAME: _____
PRODUCT NAME: Varistors
CENTRA P/N: CNR-07D220K
CUSTOMER P/N: _____

CeNtRa APPROVED STAMP		
APPROVED BY	CHECKED BY	EDITED BY
FOR CUSTOMER APPROVAL		
APPROVED BY	CHECKED BY	EDITED BY

台灣新竹廠
舜全電子股份有限公司(新竹新埔)
新竹縣新埔鎮內立里官埔路263號
CeNtRa Science Corp.
Add: No.263,Neli Sec., Guanpu Rd.,
Xinpu Township,Hsinchu county
305,Taiwan(R.O.C).
TEL: 886-3-5887892
FAX: 866-3-5887891
Http:www.cnr.com.tw

中國東莞廠
舜全電氣器材(東莞)有限公司
廣東省東莞市虎門鎮白沙四村
CeNtRa Science (Holdings)Ltd.
Add:4th Village Bai Sha Humen Town,
Dong Guan City,Guang Dong,China.
TEL: 86-769-85517988
FAX: 86-769-85517979

	Page :
■ Explanation of Part Numbers	1
■ Product Dimensions	2
■ Reliability	3
■ Solder Recommendation	4
■ Power Derating Curve	5
■ Packing information	6
■ Safety Approvals	7
■ Impulse Life Time Rating Curves	8
■ V-I Curves	9

Explanation of Part Numbers

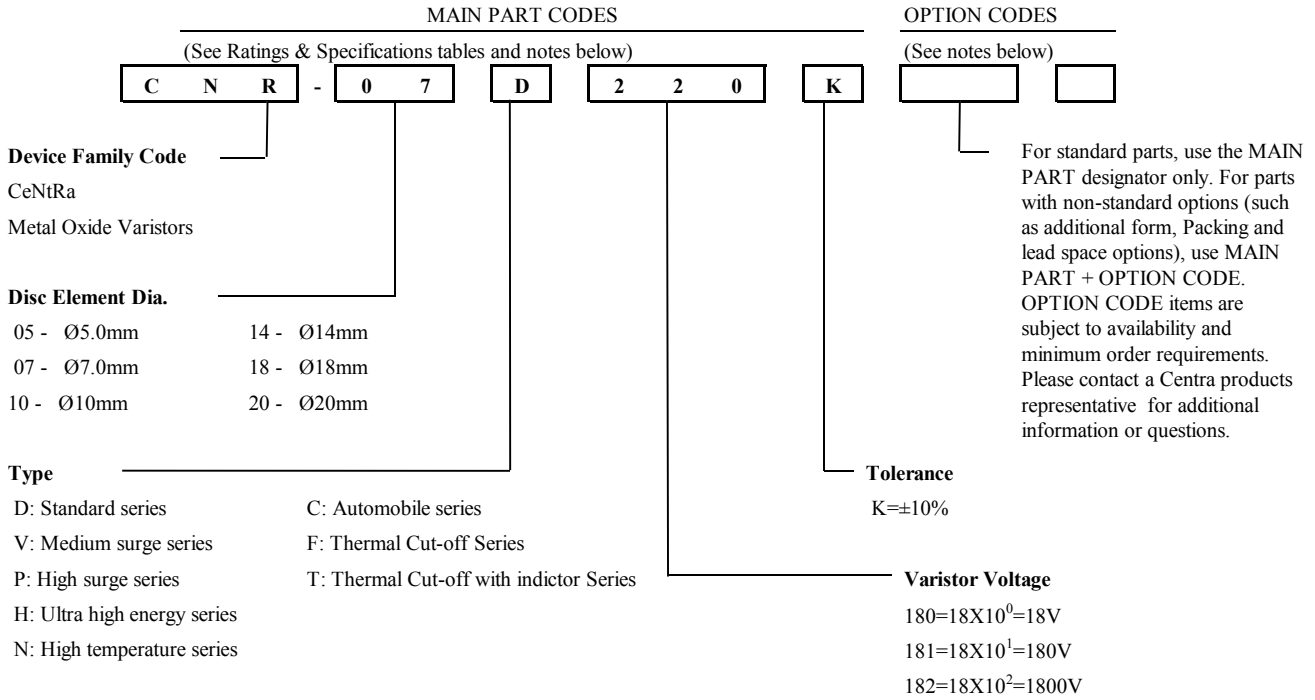

Ordering Notes:

MAIN PART CODES

Series + /Packaging/ Lead Style / Designators:

Ordering examples:

Straight Lead Bulk Pack (Standard)	Straight Lead (Short Cut) Bulk Pack	Straight Lead Tape & Reel Pack	Straight Lead Flat Box Pack
CNR-07D220K	CNR-07D220KTTSXXX	CNR-07D220KTRSX	CNR-07D220KBT SX
Outside Kink Lead Bulk Pack	Outside Kink Lead (Short Cut) Bulk Pack	Outside Kink Lead Tape & Reel Pack	Outside Kink Lead Flat Box Pack
CNR-07D220KSOK	CNR-07D220KTTKXXX	CNR-07D220KTRKX	CNR-07D220KBT KX
Inside Kink Lead Bulk Pack	Inside Kink Lead (Short Cut) Bulk Pack	Inside Kink Lead Tape & Reel Pack	Inside Kink Lead Flat Box Pack
CNR-07D220KSIK	CNR-07D220KTTIXXX	CNR-07D220KTRIX	CNR-07D220KBT IX
In Line Kink Lead Bulk Pack	In Line Kink Lead (Short Cut) Bulk Pack	In Line Kink Lead Tape & Reel Pack	In Line Kink Lead Flat Box Pack
CNR-07D220KSHK	CNR-07D220KTT HXXX	CNR-07D220KTRHX	CNR-07D220KBT HX

Option Code

+ XXX

Short Cut Lead Length 10mm±1.0mm
CNR-07D220KTT S10
Tape & Reel Pack Feed Hole Pitch
CNR-07D220KTR SA
CNR-07D220KTR SB

A: P₀ → 12.7mm±0.2mm
B: P₀ → 15.0mm±0.2mm

CeNtRa D Series varistors are shipped standard in bulk pack with straight leads or Kink lead and lead spacing outlined in the Package Dimensions section of this data sheet. Contact your CeNtRa sales representative to discuss non-standard options.

Product Dimensions

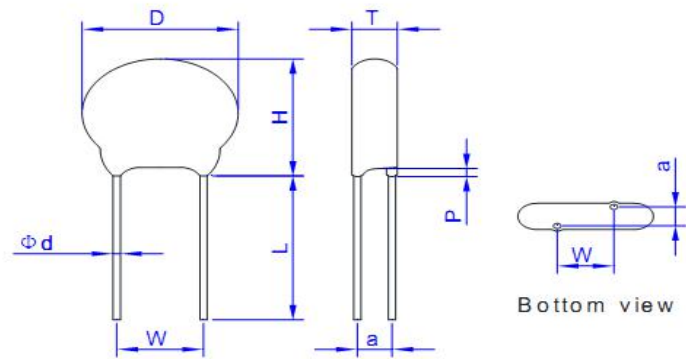

Dimension Table

Unit:mm

Symbol	Model size	07D	
		Min.	Max.
D		-	9
H		-	12
W		4	6
Ød		0.55	0.65
P(max.)		3	
L(min)		25	
T(max.)		3.8	
a(±1.0)		1.1	
		CP/AF	

Device Ratings and Characteristics

Part No.	Device Marking	Maximum Allowable Voltage		Varistor Voltage (@1mA)			Clamping Voltage @ Test Current (@8/20µs)		Maximum Energy (@10/1000µs)
		ACrms(V)	DC(V)	Vn(Vdc)	Min.	Max.	Vc(V)	Ip(A)	(J)
CNR-07D220K	07D220K	14	18	22	18.7	26	47	2.5	1.1

Part No.	Device Marking	Maximum Peak Current (@8/20µs) (A)	Rated Power (W)	Typical Capacitance (@1KHz) (pF)	LEAKAGE CURRENT AT 18V (DC) (µA)
CNR-07D220K	07D220K	250	0.02	3600	<50

Reliability			
Characteristics	Standard	Test Conditions	Specifications
Robustness of terminations	IEC 60068-2-21 Test Ua1	F = 10 N (d ≤ 0.8 mm) ,F = 20 N (d = 1 mm)	$\Delta V/V \leq \pm 5\%$ No visible damage
Solderability	IEC 60068-2-20 Test Ta (Method 1)	T = 235±5°C, d = 2±0.5s	Approximately ≥ 95%
Resistance to soldering heat	IEC 60068-2-20 Test Tb (Method 1A)	T = 260±5°C, d = 10±1s	$\Delta V/V \leq \pm 5\%$ No visible damage
Vibration	IEC 60068-2-6 Test Fc Method B4	Frequency range: 10 Hz to 55 Hz ,a = 0.75 mm or 98 m/s ² (whichever is the less), d = 3x2 h	$\Delta V/V \leq \pm 5\%$ No visible damage
Voltage proof	IEC 61051-2	Metal balls method (4.8.1.2) 2500 V, 60 s	As specified in pecification
Pulse current- 8/20 μs	IEC 61051-2	8/20 μs, 10 times, I _{peak} =0.25*Imax	$\Delta V/V \leq \pm 10\%$ No visible damage
Pulse current- 10/1000 μs	IEC 61051-2	10/1000 μs, 10 times, I _{peak} = 0.0075* Imax	$\Delta V/V \leq \pm 10\%$ No visible damage
Rapid change of temperature	IEC 60068-2-14 Test Na	N = 5 cycles, d = 30 min , θA = -40±3°C, θB = 85±2°C	$\Delta V/V \leq \pm 5\%$ No visible damage
Endurance at upper category temperature	IEC 61051-1 (4.21)	T: max temperature as specified , Duration: 1000 h, Voltage: max. a.c. voltage or max. d.c. voltage	$\Delta V/V \leq \pm 10\%$ No visible damage R ≥ 1000MΩ U ≤ 1,1 U _{initial}
Damp heat (Steady state)	IEC 60068-2-78 Test Ca	T = 40±2°C, RH = 93(+2/-3)%, 56d , 4 specimens: No voltage applied , Other 4 specimens: Applied voltage: 100% of the max. d.c. voltage	$\Delta V/V \leq \pm 10\%$ R _{ISO} ≥ 100MΩ
Varistor Voltage Temp. Coefficient	Specification Standard	V _{1mA} at -40°C, 105°C, 25°C $\frac{V_{1mA} \text{ at } 105^{\circ}\text{C} - V_{1mA} \text{ at } 25^{\circ}\text{C}}{V_{1mA} \text{ at } 25^{\circ}\text{C}} \times \frac{1}{80} \times 100(\%/^{\circ}\text{C})$ $\frac{V_{1mA} \text{ at } -40^{\circ}\text{C} - V_{1mA} \text{ at } 25^{\circ}\text{C}}{V_{1mA} \text{ at } 25^{\circ}\text{C}} \times \frac{1}{65} \times 100(\%/^{\circ}\text{C})$	-0.05 ≤ TC ≤ 0.05(%/°C)
High Temperature Storage	IEC60068-2-2	1000h, T = 125±2°C	$\Delta V/V \leq \pm 5\%$ No visible damage
Low Temperature Storage/Cold	Specification Standard	The specimen shall be subjected to -40±2 °C, without load for 1000 hours and then stored at room temperature for one to two hours. Thereafter, the change of V _c shall be measured.	$\Delta V_{cmA}/V_{cmA} \leq \pm 5\%$ No visible damage

Solder Recommendation

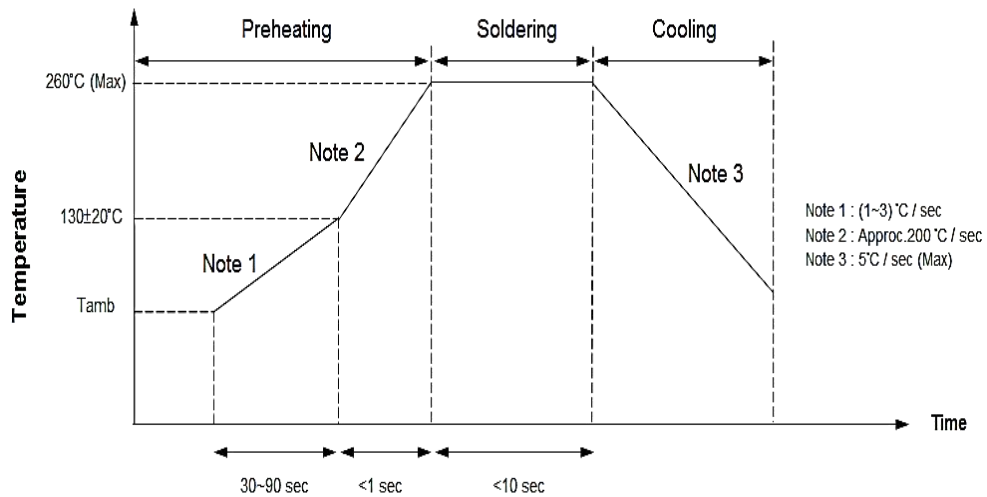

Recommendation Reworking Conditions with Soldering Iron

Item	Conditions
Temperature of soldering Iron-tip	360°C (Max)
Soldering Time	3 sec (Max)
Distance from Varistor	2mm (Min)

RoHS Compliant Declaration

We hereby declare that the components delivered to your company are compliant with RoHS Directive 2011/65/EU

Storage Conditions of Products

(I) Storage Conditions:

1. Storage Temperature: -10°C ~ +40°C
2. Relative Humidity: ≤ 75%RH
3. Keep away from corrosive atmosphere and sunlight
4. Solvent Resistance: MIL-STD-202, Method 215F
5. Moisture Sensitivity: Level 1, J-STD-020

(II) Period of Storage: 1 year

Power Derating Curve

Should transients occur in rapid succession, the average power dissipation is the energy (watt-seconds) per pulse times the number of pulses per second. The power so developed must be with the specifications shown on the Device Ratings and Specifications Table for the specific device. The operating values of a MOV need to be derated at high temperatures as shown above. Because varistors only dissipate a relatively small amount of average power they are not suitable for repetitive applications that involve substantial amounts of average power dissipation.

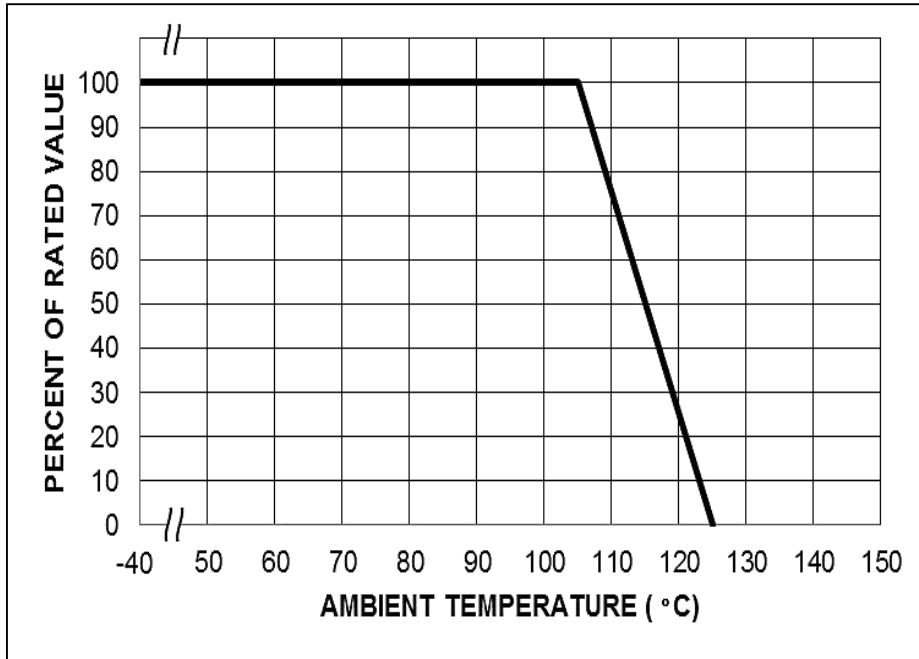

Surge Current Standard Waveform

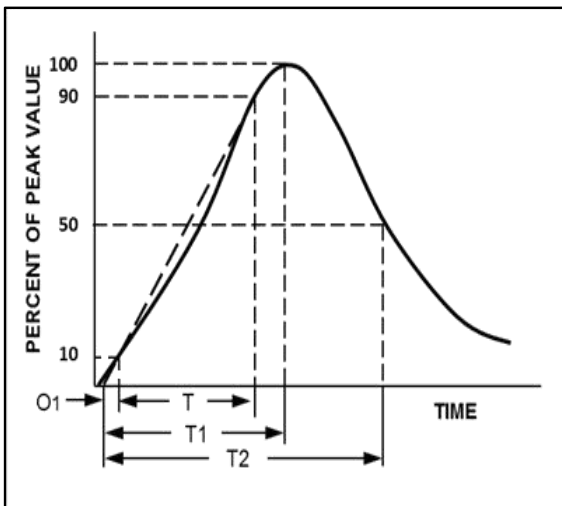

O1 = Virtual Origin of Wave
 T = Time from 10% to 90% of Peak
 T1 = Rise Time = 1.25 x T
 T2 = Decay Time

Example - For an 8/20 μ s Current Waveform:

8 μ s = T1 = Rise Time

20 μ s = T2 = Decay Time

Packing information

■ Bulk packing

Part No.	Min. Q'ty(pcs)/Bags	Q'ty(pcs)/Inner Box	Min. Q'ty(pcs)/Carton	Weight/Carton
CNR-07D220K	1000	10000	20000	Less than 20Kg

Packing Bag

unit:cm

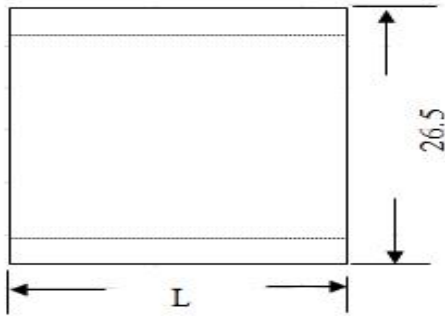

Inner box dimension

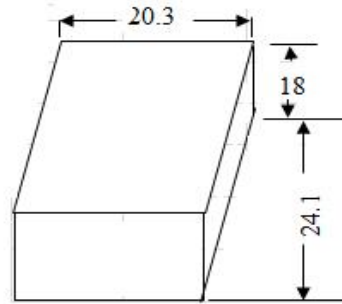

L	Series	Value
L	05D to 10D Series	10.5
	14D to 20D Series	14.5

Carton Dimensions (Height 21.5cm)

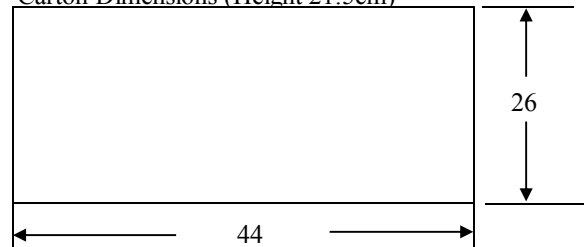

Label

CNR Zinc Oxide Varistor	
Part No.	Inspected by
Quantity	
Lot No.	

Mark

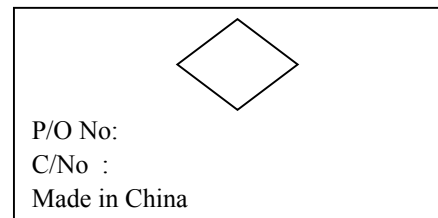

Specification

Year Code			Month Code		
W--2022	G--2014	L--2018	1--January	5--May	9--September
X--2023	H--2015	M--2019	2--February	6--June	o--October
Y--2024	J--2016	P--2020	3--March	7--July	n--November
Z--2025	K--2017	U--2021	4--April	8--August	d--December

EX.

H	1
---	---

→ Year Code
→ Month Code

Agency Approvals		
Agency	Agency Approval	Certificate No.
	UL 1449 4 th & cUL	VZCA2.E316325 VZCA8.E316325

Features

1. RoHS compliant
2. Halogen-free series are available
3. Body size: Ø07 mm

Applications

1. Power supply
2. Home appliance
3. Industrial equipment
4. Telecommunication or telephone system
5. Smart meter
6. Lighting products
7. Photovoltaic industry

Max. Rating		
	D-Series	Units
Operation Ambient Temperature Range	-40 to +105	°C
Storage Temperature Range	-40 to +125	°C
Insulation Resistance	>1000	MΩ
Typical Response Time	<25	ns

Impulse Life Time Rating Curves

CNR-07D220K

7D Series

CNR07D180K to CNR07D680K

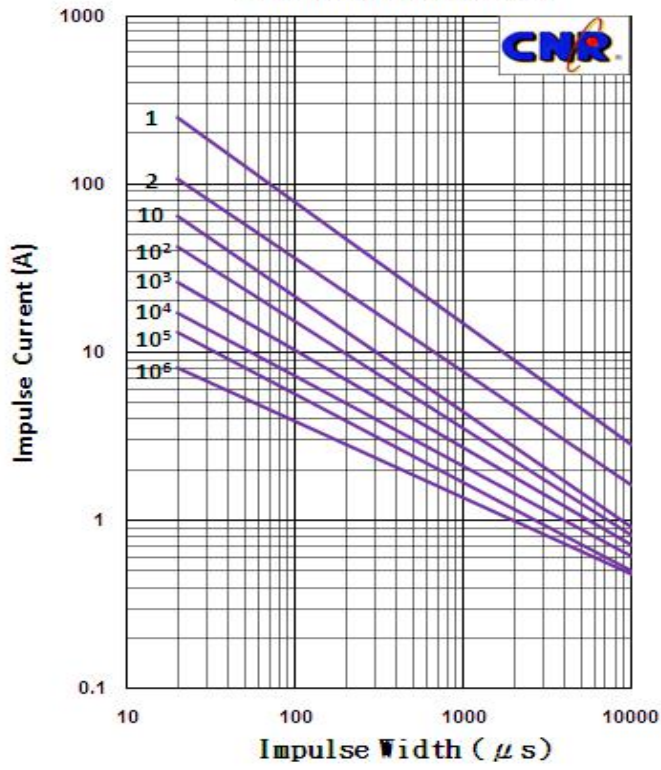

V-I Curves

CNR-07D220K

CNR-07D180K to CNR-07D680K

