

OOK/ASK MINI RECEIVER MODULE

433.92 MHz

Cod. 3-2001034HCS - 2 Channel HCS Version

Compatible with transmitter 3-2000520M (HCS Keeloq protocol)



DESCRIPTION:

2 Channel Receiver Module working on the 434 MHz ISM Band, with very compact external dimensions. The on-board receiver is a super heterodyne with OOK/ASK demodulation and a SW front end filter to improve the out of band interfering rejection. The microcontroller on board permits decoding, auto learning and memory function of the transmitter code. The firmware implements a digital filter to improve the RF performance in noisy environments.

HIGHLIGHTS:

Compliant with European Standards I-ETS 300 220 and ETS 300 683.

APPLICATIONS:

Remote control system, remote control for lighting, remote control for doors, garage doors

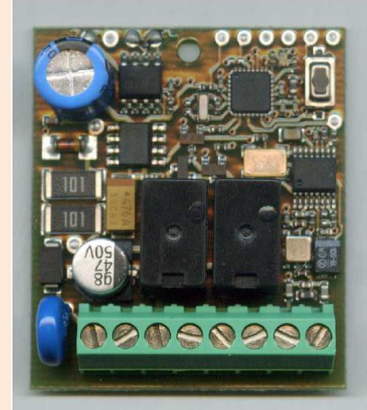

MECHANICAL CHARACTERISTICS

EXTERNAL DIMENSIONS:

H (height)	=	16 mm
W (wide)	=	40,5 mm
L (length)	=	36,5 mm

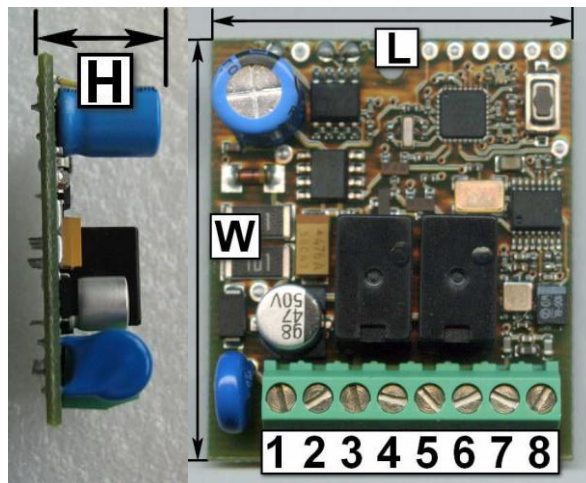

TERMINAL FUNCTIONS:

- 1) Supply Input Voltage (positive supply)
- 2) Ground (negative supply)
- 3) Relays 1 common output
- 4) Relays 1 normally open output (when active green led flashes)
- 5) Relays 2 common output
- 6) Relays 2 normally open output (when active red led flashes)
- 7) Antenna Shield
- 8) Antenna Input (50 Ohm)

ABS. MAX. RATINGS

Supply voltage:	33VAC / 35VDC
Radio Frequency Input, pin 3:	+ 20 dBm
Input/output pins voltage with respect to GND:	120V
Storage Temperature:	- 40 ÷ + 100 °C
Operating Temperature:	- 20 ÷ + 70 °C

MIPOT S.P.A.

Via Corona, n.5
(Zona Ind.)
34071 Cormons (GO)
Italy
Tel.+39 0481 630200 ra.
Fax +39 0481 62387
mipot@mipot.com



HI-TECH COMPANY

RF
WIRELESS**ELECTRICAL CHARACTERISTICS AT + 25 °C TEMPERATURE**

Parameter	Min.	Typ.	Max.	Unit	Notes
Supply Voltage(VDC)	12	-	30	Volt	
Supply Voltage (VAC)	12	-	28	Volt	
Current consumption during reception	-	11	-	mA	
Current consumption (one channel active)	-	25	-	mA	
Current consumption (two channels active)	-	36	-	mA	
Operating frequency	-	433.92	-	MHz	
Sensitivity	-	-105	-	dBm	Note 1
- 3dB RF bandwidth	-	±100	-	kHz	
Level of spurious emission	-	-	-60	dBm	
Start - up time	-	-	2.8	s	Note 2
Activation time	-	-	0.5	s	Note 3
Max load for the outputs VDC	-	-	1 A @ 24V	A @ Vdc	
Max load for the outputs VAC	-	-	1 A @ 120V	A @ Vac	

Note 1: Measure carried out with 1KHz, AM 100% square wave modulating signal.

Note 2: time from power up to valid data reception (receiver ready to work)

Note 3: time from reception to the relay activation

Note 4: All the measurements of the RF parameters carried out with 50 Ohm load connection on pin 8 (Antenna Input)

MIPOT S.P.A.

Via Corona, n.5
(Zona Ind.)
34071 Cormons (GO)
Italy
Tel.+39 0481 630200 ra.
Fax +39 0481 62387
mipot@mipot.com

APPLICATION NOTE – RELAYS: FROM N.O. TO N.C.

It is possible to change the relays outputs from Normally Open (N.O.) to Normally Closed (N.C.), just cut the micro strip line regarding the desired channel, for details see the picture below:

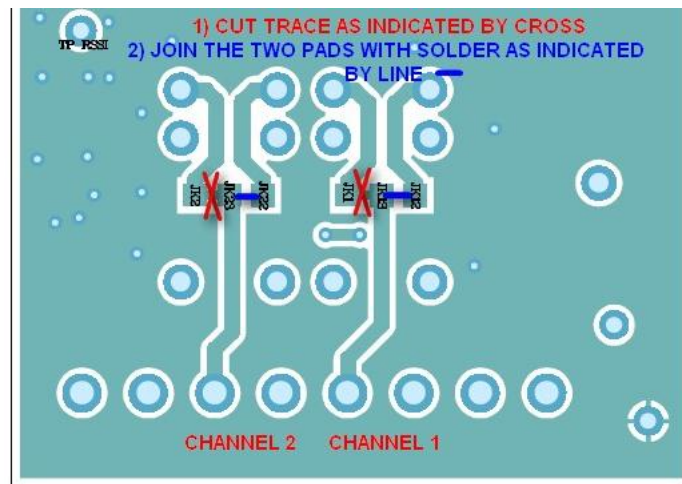

Rear PCB layer of the Receiver

After cutting remember to connect the two soldering pads!

USER'S MANUAL

RECEIVER PROGRAMMING AND CHANNEL CONFIGURATION

All receiver programming and channel configuration operations are made through one single button. The two-coloured LED (green and red, orange if both colours are on) gives information about programming and configuration phases: when the LED is green, all operations are referred to channel 1; when the LED is red, all operations are referred to channel 2.

1 - LEARNING AND ERASING REMOTE CONTROLS

Remote controls that can activate the outputs of the receiver are memorized through the learning procedure. In the erasing procedure instead *one* single remote control or *all* the remote controls stored in memory can be erased. The default phase is the normal phase: the LED is off, the outputs are activated if a remote control that was previously stored has been received. The LED lights up in *green* if the output 1 is active, in *red* if the output 2 is active or in *orange* colour if both outputs are active.

2 - ENTERING LEARNING AND ERASURE MODES

To switch from a mode to another, just press and release the button:

- 1st pressure: LED *glows green*. Learning of a remote control on channel 1;
- 2nd pressure: LED *glows green*. Learning of a remote control on channel 2;
- 3rd pressure: LED *flashes orange*. Erasure of a remote control from memory.

When the button is released, the receiver remains in the selected phase for 5 seconds. Once expired the 5 seconds time-out, the receiver exits from the selected phase; otherwise if the a valid code is received, it informs the correct memorization or erasure turning off the LED for 0,5 seconds.

When a remote control is memorized or erased the user has again a 5 seconds time-out in order to carry another memorization or erasure.

NOTE: the erasure of a single remote control in the 3rd phase is carried out regardless of the channel or channels where the remote control had been previously memorized.

Example 1: memorization of a remote control on channel 1:

- press the button and release it: the LED glows *green*;
- within 5 seconds perform a transmission with the remote control you want to memorize;
- LED is *turned off* for 0,5 seconds to confirm the memorization of the remote control;
- wait 5 seconds (or press the button again) to exit this memorization phase. When the LED is *off* the receiver is in normal mode.

Example 2: memorization of a remote control on channel 2:

- press the button 2 times: at the first pressure the LED glows *green* while at the second pressure the LED is *red*;
- within 5 seconds performs a transmission with the remote control to memorize;
- LED is *turned off* for 0,5 seconds to confirm the memorization of the remote control;
- wait 5 seconds (or press the button again) to exit the learning phase. When the LED is *off* the receiver is in normal mode.

Example 3: erasure of a remote control from memory:

- press the button 3 times: at the first pressure the LED glows *green*, at the second pressure the LED is red and at the third pressure the LED is *flashing in orange* colour;
- within 5 seconds make a transmission with the remote control to erase;
- LED turns off for 0,5 seconds to confirm erasure (if the remote control wasn't previously memorized, there is no

confirmation);

- wait 5 seconds (or press the button again) to exit the erasing phase. When the LED is *off* the receiver is in normal mode.

3 - CHANNEL CONFIGURATION

Both channels can be set up in the following configurations:

- MONOSTABLE configuration: at the reception of a correct frame, the output remains active until the frame is received;
- BISTABLE configuration: at the reception of a correct code, the output changes its state. If the output was inactive it becomes active and vice versa.
- TEMPORIZED configuration: at the reception of a correct code, the output remains active for the set up time.

4 - SELECTION OF A CHANNEL CONFIGURATION:

To enter the phase of the channels configuration keep pressed the button in the learning phase until the LED starts *flashing*.

EXAMPLES:

- channel1 configuration: press and keep pressed the button. LED turns on in *green* colour. After 3 seconds from the button pressure, the green LED starts *flashing fast*: the MONOSTABLE configuration is selected;
- channel2 configuration: press and release the button. LED turns on in *green* colour. Press the button a second time and keep it pressed. LED turns on in *red* colour. After 3 seconds from the button pressure, the red LED starts *flashing fast*: the MONOSTABLE configuration is selected.

If the button is not pressed again, after 5 seconds the LED makes a *slow flash*: it indicates that the selected channel has been configured as MONOSTABLE.

If the button is pressed again during the *fast flashing*, the BISTABLE configuration is selected. It's indicated by 2 *fast flashes repeated continuously*. If the button is not pressed in the next 5 seconds, the LED makes 2 *slow flashes* to indicate that the selected channel has been configured as BISTABLE.

Pressing the button again while the LED *flashes fast*, the TEMPORIZED configuration is selected: the LED makes 3 *fast flashes continuously*. If the button is not pressed in the next 5 seconds, the *orange* LED turns on (for both channels). If the button is not pressed within 3 seconds after the *orange* LED turns on, the TEMPORIZED configuration is confirmed and the activation time is set to the default value, that is 60 seconds.

If the button is pressed when the LED is *orange*, the button pressure is indicated by turning on the LED in the colour of the selected channel for 0,5 seconds. At every button pressure, the activation time is increased by 5 seconds. For example, if the button is pressed 4 times, the activation time will be 20 seconds. When there's a pause of 3 seconds from the last button pressure, the TEMPORIZED configuration is confirmed and the number of button pressures are indicated by an equally number of passages from *orange* colour to the colour of the selected channel.

The maximum time that's possible to set is 20 minutes that is 240 button pressures.

5 - EXIT FROM CHANNEL CONFIGURATION

If the button is pressed during the 3 *fast flashes* indicating the TEMPORIZED configuration, the receiver returns to the normal mode without making changes on channels configuration.

6 - ERASURE OF MEMORY

To cancel all remote controls from memory keep the button pressed during the third pressure (receiver is entered in the erasing phase) until the LED *stops flashing* and remains on with the *orange* colour. At this point, the user can release the button.

When the LED turns off, the memory has been cancelled and both channels are set to MONOSTABLE configuration.

NOTES

A1 - Memory error

When there's an error about the memory where all codes are stored, the orange LED flashes continuously. In this case it's necessary to call assistance.

A2 - Maximum number of remote controls that's possible to store:

Version 3-2001034HCS = 500 remote controls

A3 - Output activation

Output activation is signalled turning on the relative LED: when the output 1 is active, the *green* LED glows; while if the output 2 is active, the *red* LED glows.

If the LED glows *orange*, both channels are active.

MIPOT S.P.A.

Via Corona, n.5
(Zona Ind.)
34071 Cormons (GO)
Italy
Tel.+39 0481 630200 ra.
Fax +39 0481 62387
mipot@mipot.com

GUIDELINES FOR CORRECT POWER SUPPLY AND GROUND PLANE LAYOUT DESIGN IN RECEIVING APPLICATIONS

In dealing with applications that use Mipot Receiver Modules, care must be taken in designing the layout of the ground plane and power supply paths with particular attention to some general rules as described in the following sections.

Below is a typical layout of the solder side of a PCB suited for a receiver, including pin-out numbering:

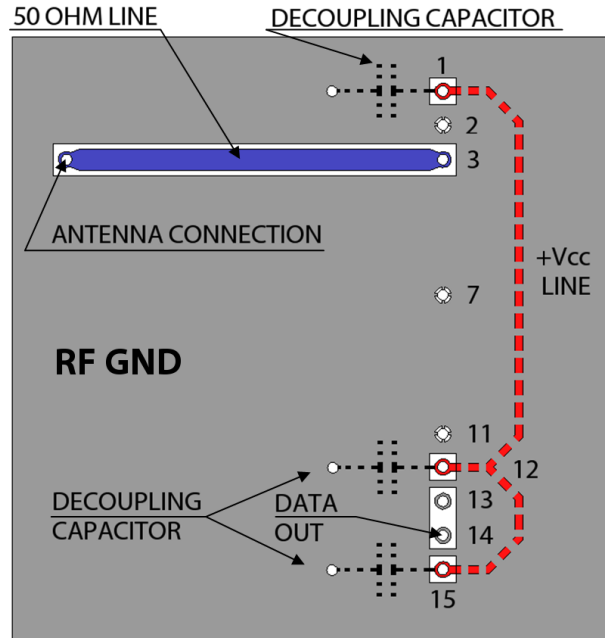

Note: Dotted elements must be placed on component side (PCB side opposite to ground layer).

Note: This is a general layout, in some modules it could be slightly different (e.g. pin 1 and/or pin 15 not mounted)

Ground Layer:

- Must be present around the antenna output area;
- Must cover all the area around the receiver module;
- Circuit should be realized on two side PCB, connecting both sides with pass-through far at least 15 mm each other.

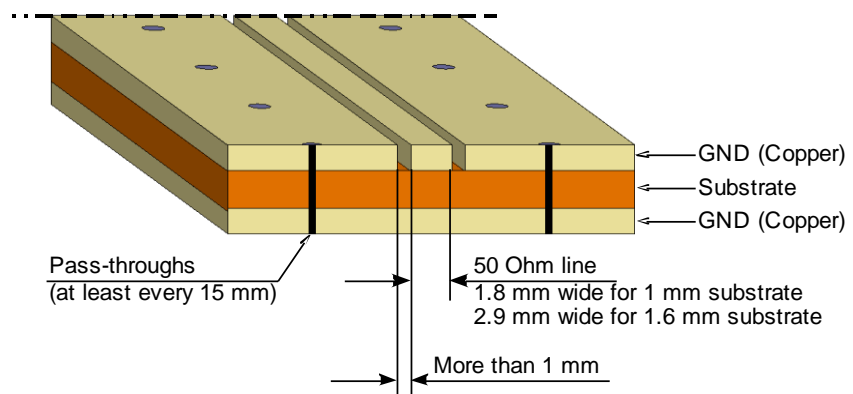

Note: the dimensions in the picture above are referred to a FR4 substrate PCB

Supply Path:

- Needs a good filtered DC component;
- Place decoupling ceramic capacitors directly on supply pin(s), taking care to use different capacitance values at different pins (10 to 1000nF).

Antenna line:

- Should be kept as short as possible in order to reduce losses.

Another fundamental issue when dealing with supply paths is to ensure a good decoupling between Digital, RF and Power circuitry.

Below is the recommended Power Supply Path structure to be followed:

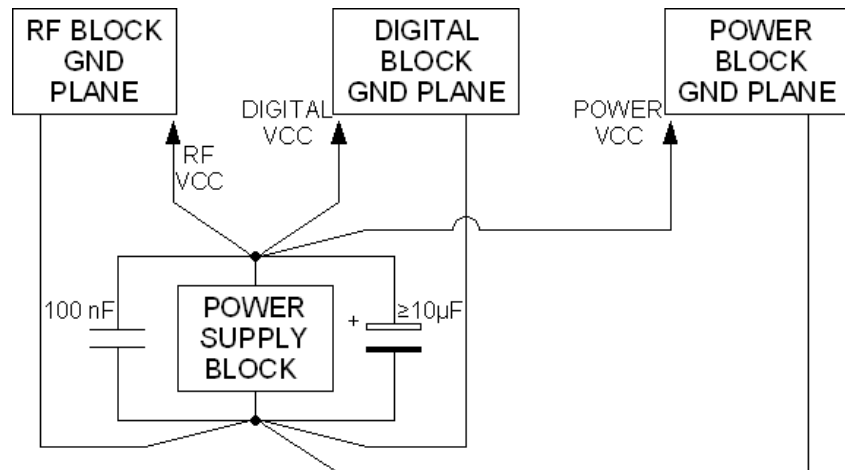

Keep separate paths for:

- RF block;
- Digital block;
- Power block.

HINTS FOR ANTENNA SELECTION

A good antenna design is required to achieve the maximum performances from Mipot modules and obtain the required range.

The recommended antenna is a **Quarter-Wave Monopole Antenna** positioned vertically on a ground plane having a radius $R \geq L$ (where L is the antenna length corresponding to $\frac{1}{4}$ wave length), in an area that has to be kept free from other components and metallic objects.



The antenna length can be quickly determined as $L[\text{cm}] = 7500 / \text{Frequency}[\text{MHz}]$. Typical length for a quarter wave antenna operating at 434MHz is 17cm (6.7 inch), for a frequency of 868MHz the length will be 8.6 cm (3.4 inch), bearing aware that some corrections will be necessary in depending upon the thickness, the material, the eventual coating etc., in order to obtain a correctly tuned device. It is also to be noticed that using a planar ground the antenna impedance is approximately equal to 350ohm (i.e. $\frac{1}{2}$ impedance of a dipole), so a matching network will be useful to improve the efficiency.

Example of $\lambda/4$ antenna for 868MHz

If this type of antenna is not usable (e.g. in portable devices) other solutions are obviously possible, keeping in mind that antenna design varies depending on the specific application, the materials used, the layout structure and the size of the ground plane, so a *specific design* is recommended to get the maximum performance.

In designing antennas it is useful to follow some general considerations:

- keep the area near the antenna as free as possible from other components and metallic objects
- avoid tracks and ground planes near the area of the antenna
- where possible use a large ground plane having a radius $R \geq L$, where L is the antenna length, placing the antenna in the center
- ensure good electrical connections of the ground layer
- use 50 Ohm coax cable with low insertion loss if long connections are used.

An alternative to an antenna specific design is the use of some commonly used antenna solutions which can give satisfactory results if correctly chosen and dimensioned:

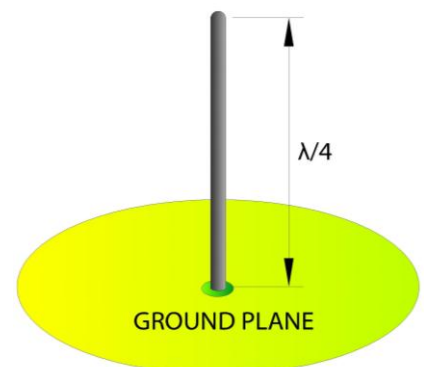

MIPOT S.P.A.

Via Corona, n.5
(Zona Ind.)
34071 Cormons (GO)
Italy
Tel.+39 0481 630200 ra.
Fax +39 0481 62387
mipot@mipot.com

- **PCB trace antenna:**
If the size of the device allows, it should be also a quarter-wave antenna. Shorter antennas implicate a loss of efficiency and a poor range. Trace length could be 10% to 20% shorter than the theoretical value, depending on the dielectric and the thickness of the PCB. If the device is to be handheld, the antenna could be even shorter, to compensate the effect of human body.

- **Helical antenna:**

This is typically a coil which is wound with copper, phosphor bronze or steel wire, with an open end and the other connected to the RF device. The number of turns is depending upon coil diameter, spacing of the turns and diameter of the wire, so it can be determined by winding a coil with a great number of turns and reducing them by cutting until it is tuned at the operating frequency. Fine tuning can be achieved by spreading or compressing the coil. If the coil is wound tightly enough, it may be shorter than one-tenth of a wavelength.

Thanks to its high Q factor, this antenna has typically a narrow bandwidth, and the spacing of the turns has great influence on the performance. For this reasons it can be easily de-tuned by nearby objects, including human body, so it might not be suitable for handheld devices.

This antenna must have a good ground plane, and its performance is very sensitive to antenna position with respect to the ground plane. It is also preferable not to have a long transmission line interposed between the antenna and receiver, but connect it as close as possible to the RF device.

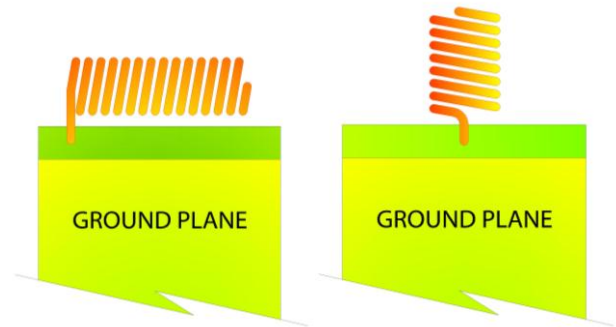

- **PCB Loop antenna:**

This is typically a PCB track with one end tied to ground and the other end connected to the RF device via a tuning circuit (e. g. pi-network) whose scope is to tune and match the low real part impedance antenna to the 50 Ohm TX/RX device output.

It is the least efficient antenna, having an efficiency loss of at least 15-20dB with respect to the quarter wave antenna, but has the advantage that it is not easily detuned by hand effects, so it is often used in handheld transmitters.

Since it has very low gain and a narrow bandwidth, the loop should not have a too small radius to avoid poorer efficiency performance and care should be taken in tuning through the matching network.

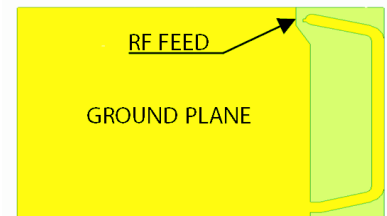

PCB loop antenna