

DATA SHEET

For a complete data sheet, please also download:

- The IC04 LOCMOS HE4000B Logic Family Specifications HEF, HEC
- The IC04 LOCMOS HE4000B Logic Package Outlines/Information HEF, HEC

HEF40195B

MSI

4-bit universal shift register

Product specification
File under Integrated Circuits, IC04

January 1995

4-bit universal shift register

HEF40195B MSI

DESCRIPTION

The HEF40195B is a fully synchronous edge-triggered 4-bit shift register with a clock input (CP), four synchronous parallel data inputs (P₀ to P₃), two synchronous serial data inputs (J, \bar{K}), a synchronous parallel enable input (\overline{PE}), buffered parallel outputs from all 4-bit positions (O₀ to O₃), a buffered inverted output from the last bit position (\bar{O}_3) and an overriding asynchronous master reset input (\overline{MR}). Each register stage is of a D-type master-slave flip-flop. Operation is synchronous (except for \overline{MR}) and is edge-triggered on the LOW to HIGH transition of the CP

input. When \overline{PE} is LOW, data are loaded into the register from P₀ to P₃ on the LOW to HIGH transition of CP. When \overline{PE} is HIGH, data are shifted into the first register position from J and \bar{K} and all the data in the register are shifted one position to the right on the LOW to HIGH transition of CP. D-type entry is obtained by interconnecting J and \bar{K} . When J is HIGH and \bar{K} is LOW, the first stage is in the toggle mode. When J is LOW and \bar{K} is HIGH, the first stage is in the hold mode. A LOW on \overline{MR} resets all four bit positions (O₀ to O₃ = LOW, \bar{O}_3 = HIGH) independent of all other input conditions.

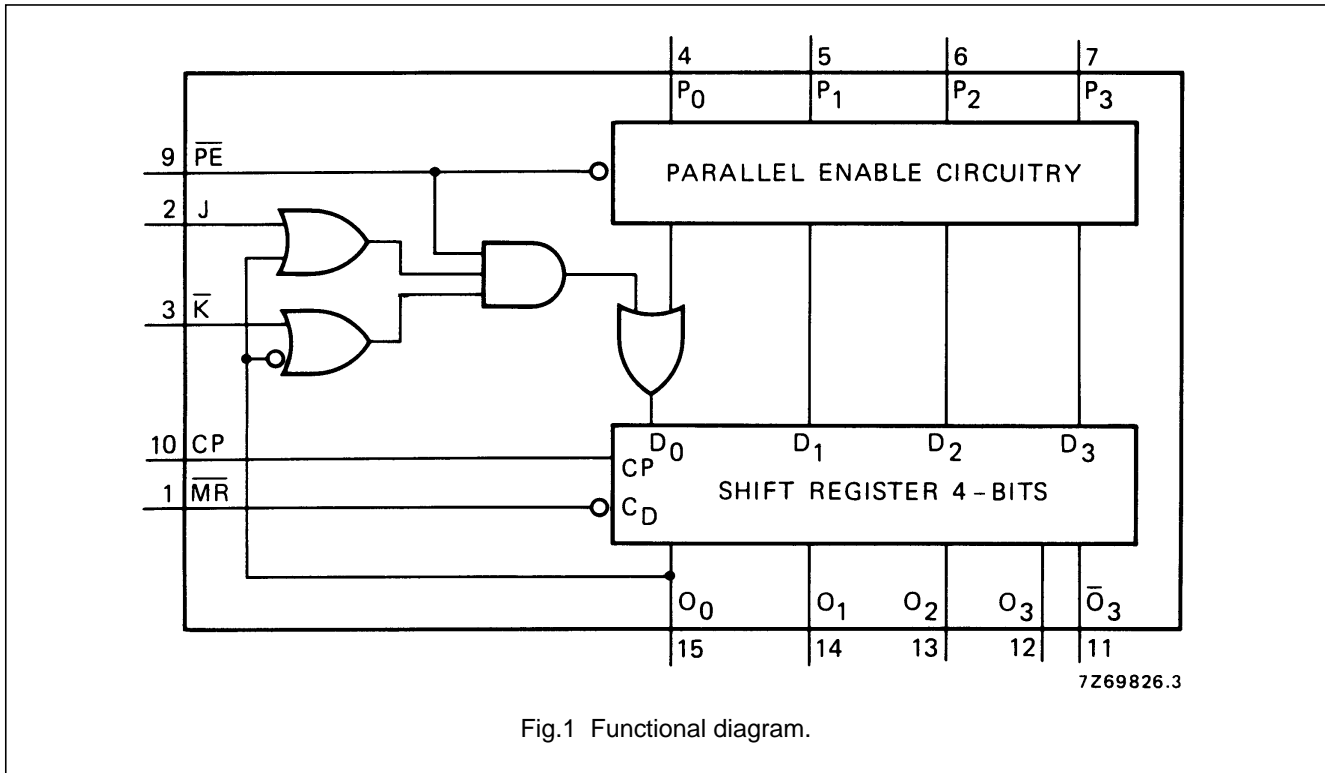

Fig.1 Functional diagram.

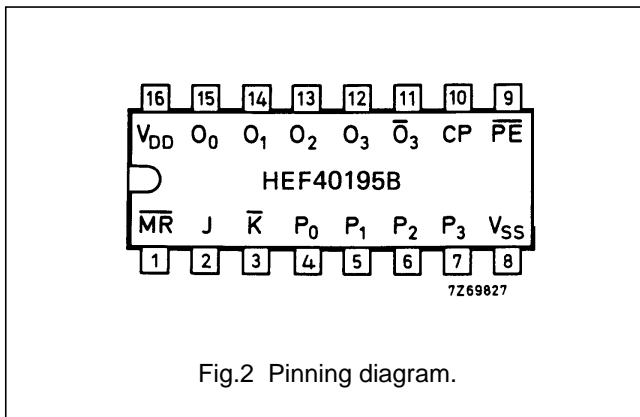

Fig.2 Pinning diagram.

- HEF40195BP(N): 16-lead DIL; plastic (SOT38-1)
- HEF40195BD(F): 16-lead DIL; ceramic (cerdip) (SOT74)
- HEF40195BT(D): 16-lead SO; plastic (SOT109-1)
- (): Package Designator North America

FAMILY DATA, I_{DD} LIMITS category MSI

See Family Specifications

4-bit universal shift register

HEF40195B
MSI

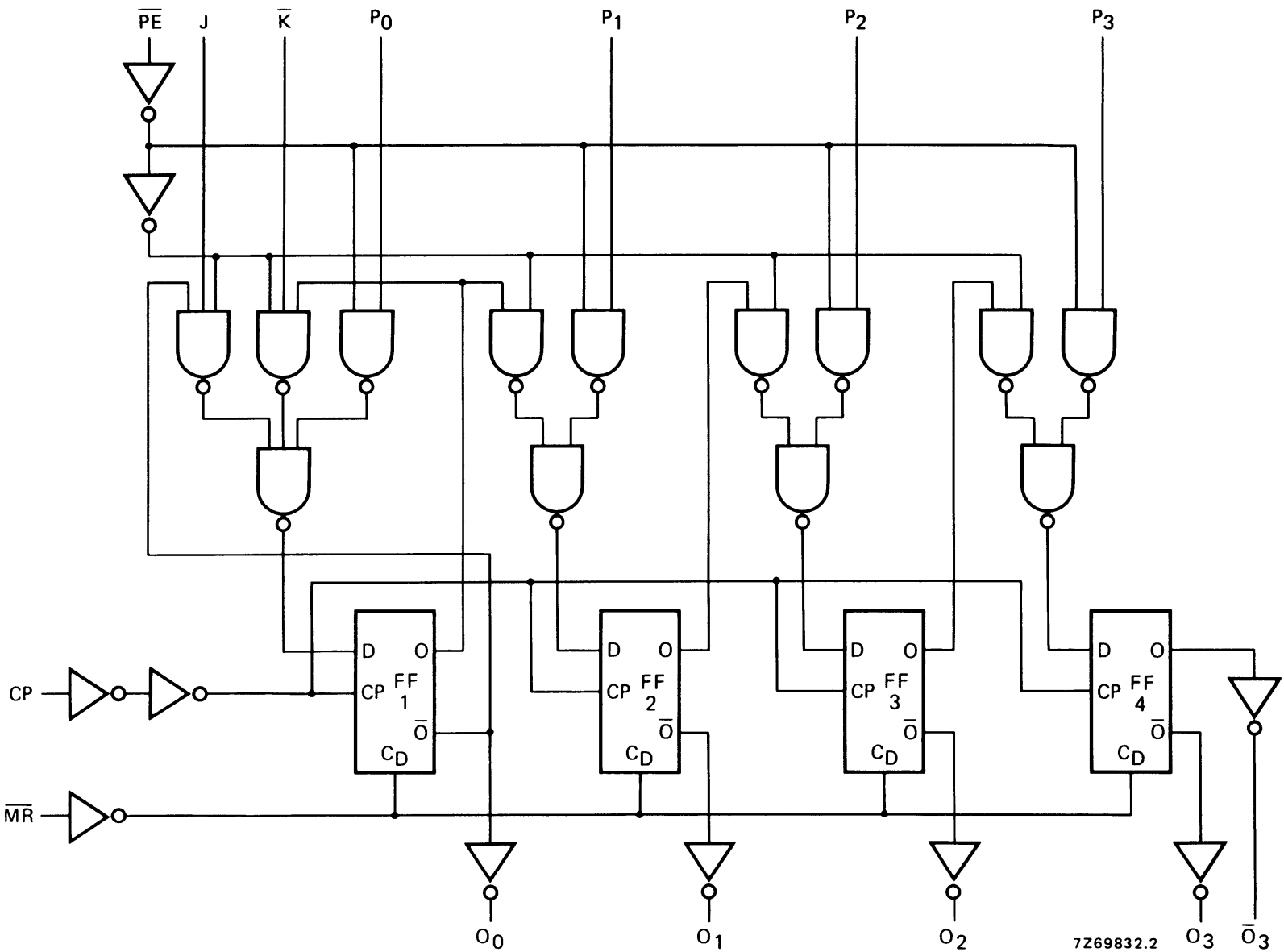

Fig.3 Logic diagram.

4-bit universal shift register

HEF40195B
MSI

PINNING

\overline{PE}	parallel enable input (active LOW)
P_0 to P_3	parallel data inputs
J	first stage J-input (active HIGH)
\overline{K}	first stage K-input (active LOW)
CP	clock input (LOW to HIGH edge triggered)
\overline{MR}	master reset input (active LOW)
O_0 to O_3	buffered parallel outputs
\overline{O}_3	buffered inverted output from last stage

FUNCTION TABLE

OPERATING MODE	INPUTS ($\overline{MR} = \text{HIGH}$)							OUTPUTS AT t_{n+1}				
	\overline{PE}	J	\overline{K}	P_0	P_1	P_2	P_3	O_0	O_1	O_2	O_3	\overline{O}_3
shift mode	H	L	L	X	X	X	X	L	O_0	O_1	O_2	\overline{O}_2
	H	L	H	X	X	X	X	O_0	O_0	O_1	O_2	\overline{O}_2
	H	H	L	X	X	X	X	\overline{O}_0	O_0	O_1	O_2	\overline{O}_2
	H	H	H	X	X	X	X	H	O_0	O_1	O_2	\overline{O}_2
parallel entry mode	L	X	X	L	L	L	L	L	L	L	L	H
	L	X	X	H	H	H	H	H	H	H	H	L

Notes

1. H = HIGH state (the more positive voltage)
2. L = LOW state (the less positive voltage)
3. X = state is immaterial
4. t_{n+1} = state after next LOW to HIGH transition of CP

4-bit universal shift register

HEF40195B
MSI**AC CHARACTERISTICS** $V_{SS} = 0\text{ V}$; $T_{amb} = 25\text{ °C}$; $C_L = 50\text{ pF}$; input transition times $\leq 20\text{ ns}$

	V_{DD} V	SYMBOL	MIN.	TYP.	MAX.	TYPICAL EXTRAPOLATION FORMULA		
Propagation delays $CP \rightarrow O_n$ HIGH to LOW	5	t_{PHL}		105	215	ns	$78\text{ ns} + (0,55\text{ ns/pF}) C_L$	
	10			50	95	ns	$39\text{ ns} + (0,23\text{ ns/pF}) C_L$	
	15			35	65	ns	$27\text{ ns} + (0,16\text{ ns/pF}) C_L$	
	LOW to HIGH	5	t_{PLH}		90	180	ns	$63\text{ ns} + (0,55\text{ ns/pF}) C_L$
		10			45	85	ns	$34\text{ ns} + (0,23\text{ ns/pF}) C_L$
		15			30	60	ns	$22\text{ ns} + (0,16\text{ ns/pF}) C_L$
$CP \rightarrow \overline{O}_3$ HIGH to LOW	5	t_{PHL}		125	255	ns	$98\text{ ns} + (0,55\text{ ns/pF}) C_L$	
	10			50	100	ns	$39\text{ ns} + (0,23\text{ ns/pF}) C_L$	
	15			35	70	ns	$27\text{ ns} + (0,16\text{ ns/pF}) C_L$	
	LOW to HIGH	5	t_{PLH}		120	240	ns	$93\text{ ns} + (0,55\text{ ns/pF}) C_L$
		10			50	105	ns	$39\text{ ns} + (0,23\text{ ns/pF}) C_L$
		15			35	75	ns	$27\text{ ns} + (0,16\text{ ns/pF}) C_L$
$\overline{MR} \rightarrow O_n$ HIGH to LOW	5	t_{PHL}		100	205	ns	$73\text{ ns} + (0,55\text{ ns/pF}) C_L$	
	10			45	90	ns	$34\text{ ns} + (0,23\text{ ns/pF}) C_L$	
	15			30	65	ns	$22\text{ ns} + (0,16\text{ ns/pF}) C_L$	
	LOW to HIGH	5	t_{PLH}		125	235	ns	$98\text{ ns} + (0,55\text{ ns/pF}) C_L$
		10			55	115	ns	$44\text{ ns} + (0,23\text{ ns/pF}) C_L$
		15			40	85	ns	$32\text{ ns} + (0,16\text{ ns/pF}) C_L$
Output transition times	5	t_{THL}		60	120	ns	$10\text{ ns} + (1,0\text{ ns/pF}) C_L$	
	10			30	60	ns	$9\text{ ns} + (0,42\text{ ns/pF}) C_L$	
	15			20	40	ns	$6\text{ ns} + (0,28\text{ ns/pF}) C_L$	
	LOW to HIGH	5	t_{TLH}		60	120	ns	$10\text{ ns} + (1,0\text{ ns/pF}) C_L$
		10			30	60	ns	$9\text{ ns} + (0,42\text{ ns/pF}) C_L$
		15			20	40	ns	$6\text{ ns} + (0,28\text{ ns/pF}) C_L$

4-bit universal shift register

HEF40195B
MSI**AC CHARACTERISTICS** $V_{SS} = 0\text{ V}$; $T_{amb} = 25\text{ }^{\circ}\text{C}$; $C_L = 50\text{ pF}$; input transition times $\leq 20\text{ ns}$

	V_{DD} V	SYMBOL	MIN.	TYP.	MAX.	
Set-up times $J, \bar{K} \rightarrow CP$ $P_n \rightarrow CP$ $\bar{PE} \rightarrow CP$	5	t_{su}	70	35	ns	see also waveforms Figs 4 and 5
	10		20	10	ns	
	15		10	5	ns	
	5	t_{su}	85	40	ns	
	10		25	10	ns	
	15		10	5	ns	
	5	t_{su}	115	55	ns	
	10		45	20	ns	
	15		30	15	ns	
Hold times $J, \bar{K} \rightarrow CP$ $P_n \rightarrow CP$ $\bar{PE} \rightarrow CP$	5	t_{hold}	15	-20	ns	
	10		5	-5	ns	
	15		0	-5	ns	
	5	t_{hold}	20	-25	ns	
	10		10	-5	ns	
	15		0	-5	ns	
	5	t_{hold}	10	-50	ns	
	10		5	-20	ns	
	15		5	-10	ns	
Minimum clock pulse width; LOW	5	t_{WCPL}	60	30	ns	
	10		25	10	ns	
	15		20	10	ns	
Minimum \bar{MR} pulse width; HIGH	5	t_{WMRL}	100	50	ns	
	10		40	20	ns	
	15		30	15	ns	
Recovery time for \bar{MR}	5	t_{RMR}	30	10	ns	
	10		15	5	ns	
	15		15	5	ns	
Maximum clock pulse frequency	5	f_{max}	5	10	MHz	
	10		14	28	MHz	
	15		19	39	MHz	

4-bit universal shift register

HEF40195B
MSI

	V_{DD} V	TYPICAL FORMULA FOR P (μ W)	
Dynamic power dissipation per package (P)	5	$1900 f_i + \sum (f_o C_L) \times V_{DD}^2$	where
	10	$8300 f_i + \sum (f_o C_L) \times V_{DD}^2$	f_i = input freq. (MHz)
	15	$22\ 800 f_i + \sum (f_o C_L) \times V_{DD}^2$	f_o = output freq. (MHz)
			C_L = load capacitance (pF)
			$\sum (f_o C_L)$ = sum of outputs
			V_{DD} = supply voltage (V)

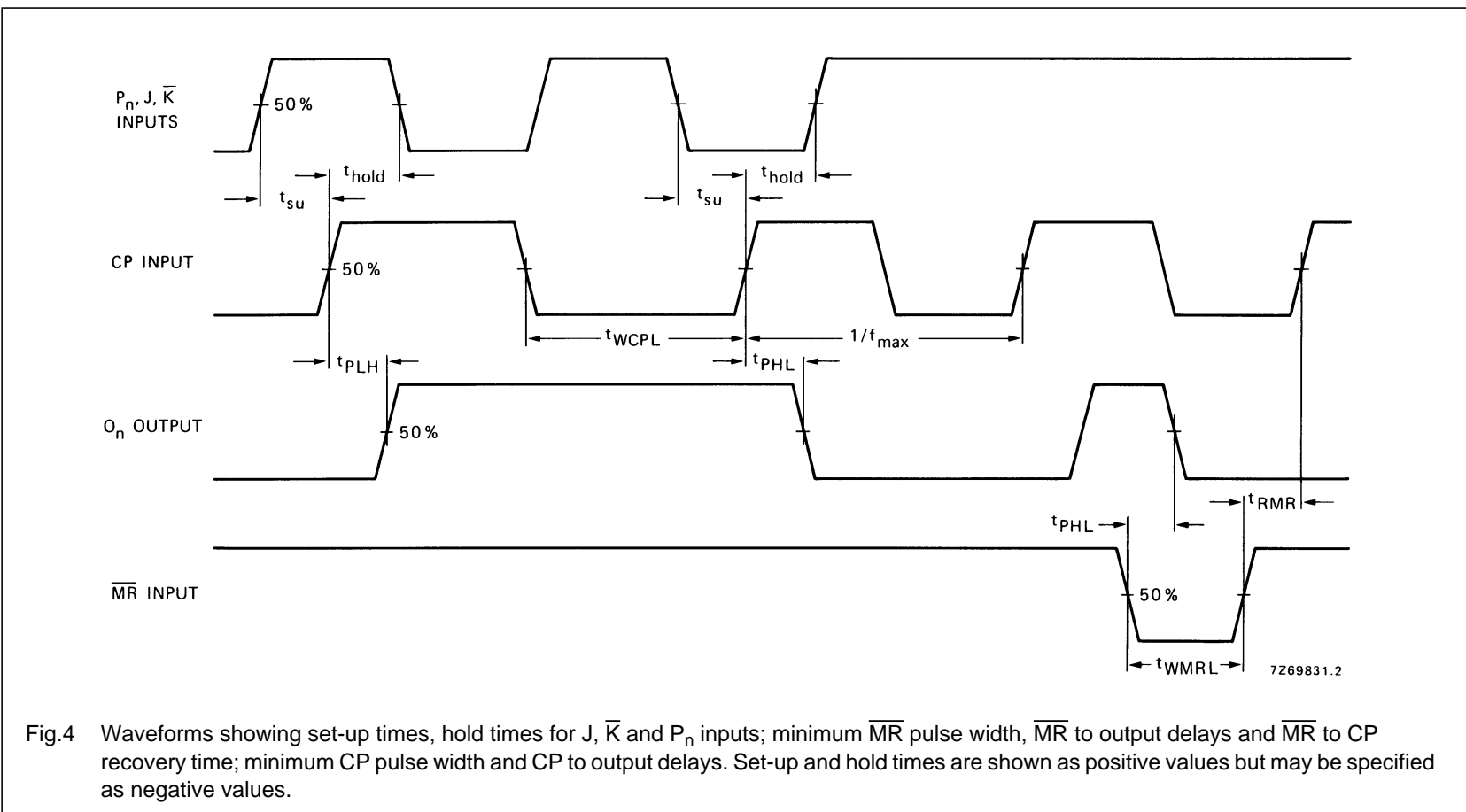

Fig.4 Waveforms showing set-up times, hold times for J, \bar{K} and P_n inputs; minimum \bar{MR} pulse width, \bar{MR} to output delays and \bar{MR} to CP recovery time; minimum CP pulse width and CP to output delays. Set-up and hold times are shown as positive values but may be specified as negative values.

4-bit universal shift register

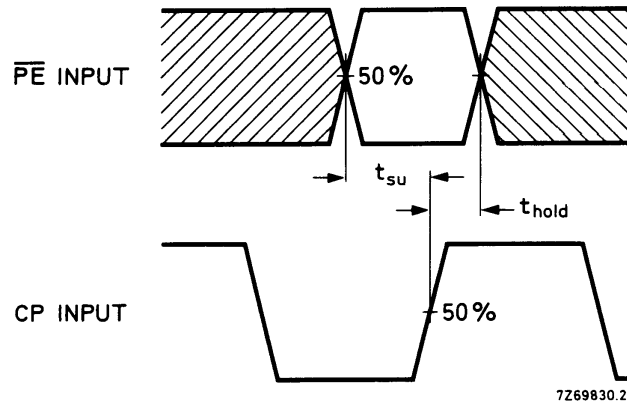
HEF40195B
MSI

Fig.5 Waveforms showing set-up and hold times for \overline{PE} input. Set-up and hold times are shown as positive values but may be specified as negative values.

APPLICATION INFORMATION

Some examples of applications for the HEF40195B are:

- Serial data transfer
- Parallel data transfer
- Serial to parallel data transfer
- Parallel to serial data transfer