

**13-INPUT NAND GATE**

**DESCRIPTION**

The T74LS133 is a high speed 13-INPUT NAND GATE fabricated in silicon LOW POWER SCHOTTKY technology.

**SCHEMATIC**

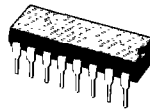
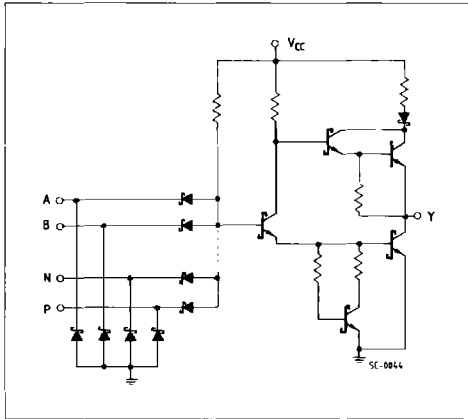

**B1**  
(Plastic Package)

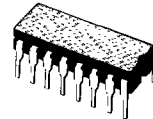

**D1**  
(Ceramic Package)



**M1**  
(Micro Package)



**C1**  
(Plastic Chip Carrier)

**ORDER CODES :**  
T74LS133 D1      T74LS133 C1  
T74LS133 B1      T74LS133 M1

**PIN CONNECTION (top view)**

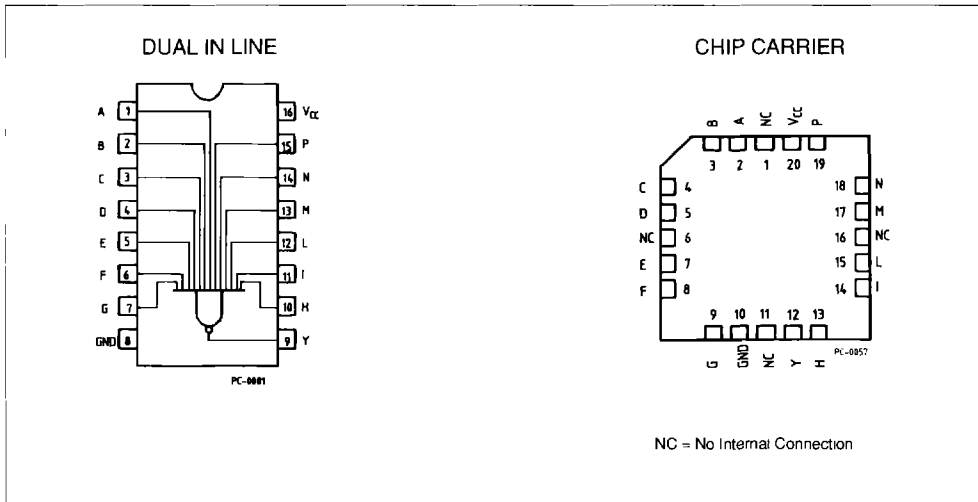

## LOGIC DIAGRAM AND TRUTH TABLE

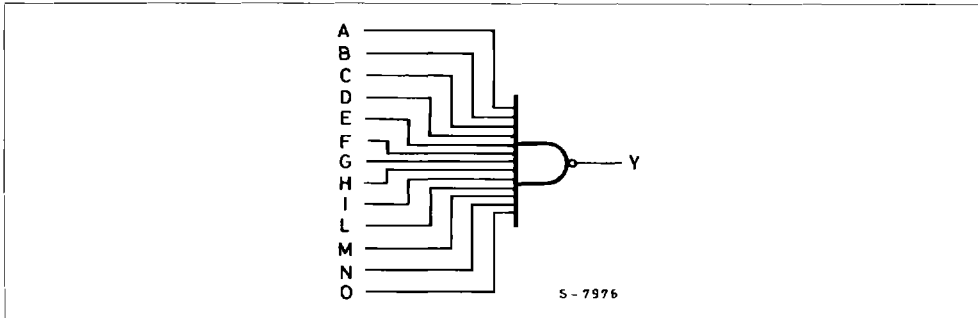

## ABSOLUTE MAXIMUM RATINGS

Symbol	Parameter	Value	Unit
$V_{CC}$	Supply Voltage	- 0.5 to 7	V
$V_I$	Input Voltage, Applied to Input	- 0.5 to 15	V
$V_O$	Output Voltage, Applied to Output	- 0.5 to 10	V
$I_I$	Input Current, into Inputs	- 30 to 5	mA
$I_O$	Output Current, into Outputs	60	mA

Stresses in excess of those listed under "Absolute Maximum Ratings" may cause permanent damage to the device. This is a stress rating only and functional operation of the device at these or any other conditions in excess of those indicated in the operational sections of this specification is not implied. Exposure to absolute maximum rating conditions for extended periods may affect device reliability.

## GUARANTEED OPERATING RANGE

Part Numbers	Supply Voltage			Temperature
	Min.	Typ.	Max.	
T74LS133XX	4.75 V	5.0 V	5.25 V	0 °C to + 70 °C

XX = package type.

## DC CHARACTERISTICS OVER OPERATING TEMPERATURE RANGE

Symbol	Parameter	Limits			Test Condition (note 1)	Unit
		Min.	Typ. (*)	Max.		
V <sub>IH</sub>	Input HIGH Voltage	2.0			Guaranteed Input HIGH Voltage	V
V <sub>IL</sub>	Input LOW Voltage			0.8	Guaranteed Input LOW Voltage	V
V <sub>CD</sub>	Input Clamp Diode Voltage		- 0.65	- 1.5	V <sub>CC</sub> = MIN, I <sub>IN</sub> = -18 mA	V
V <sub>OH</sub>	Output HIGH Voltage	2.7	3.4		V <sub>CC</sub> = MIN, I <sub>OH</sub> = - 400 μA V <sub>IN</sub> = V <sub>IL</sub>	μA
V <sub>OL</sub>	Output LOW Voltage		0.25	0.4	I <sub>OL</sub> = 4.0 mA	V <sub>CC</sub> = MIN
			0.35	0.5	I <sub>OL</sub> = 8.0 mA	V <sub>IN</sub> = 2.0 V
I <sub>IH</sub>	Input HIGH Current		1.0	20	V <sub>CC</sub> = MAX, V <sub>IN</sub> = 2.7 V	μA
				0.1	V <sub>CC</sub> = MAX, V <sub>IN</sub> = 7.0 V	mA
I <sub>IL</sub>	Input LOW Current			- 0.4	V <sub>CC</sub> = MAX, V <sub>IN</sub> = 0.4 V	mA
I <sub>OS</sub>	Output Short Circuit Current (note 2)	- 20		- 100	V <sub>CC</sub> = MAX, V <sub>OUT</sub> = 0 V	mA
I <sub>CCH</sub>	Supply Current HIGH		0.35	0.5	V <sub>CC</sub> = MAX, V <sub>IN</sub> = 0 V	mA
I <sub>CCL</sub>	Supply Current LOW		0.6	1.1	V <sub>CC</sub> = MAX, Inputs Open	mA

Notes : 1. For conditions shown as MIN or MAX, use the appropriate value specified under guaranteed operating ranges  
 2. Not more than one output should be shorted at a time.

(\*) Typical values are at V<sub>CC</sub> = 5.0 V, T<sub>A</sub> = 25 °C.

AC CHARACTERISTICS: T<sub>A</sub> = 25°C (for AC test circuits and waveforms see databook introduction)

Symbol	Parameter	Limits			Test Conditions	Unit
		Min.	Typ.	Max.		
t <sub>PLH</sub>	Turn Off Delay, Input to Output		10	15	V <sub>CC</sub> = 5.0 V C <sub>L</sub> = 15 pF	ns
t <sub>PHL</sub>	Turn On Delay, Input to Output		25	38		ns