



DC COMPONENTS CO., LTD.

RECTIFIER SPECIALISTS

**KBL / RS
005 / 401
THRU
KBL / RS
10 / 407**

TECHNICAL SPECIFICATIONS OF SINGLE-PHASE SILICON BRIDGE RECTIFIER

VOLTAGE RANGE - 50 to 1000 Volts

CURRENT - 4.0 Amperes

FEATURES

- * Ideal for printed circuitboard
- * Surge overload rating:200 Amperes peak
- * Molded structure

MECHANICAL DATA

- * Case: Molded plastic
- * Epoxy: UL 94V-0 rate flame retardant
- * Lead: MIL-STD-202E, Method 208 guaranteed
- * Polarity: Symbols molded or marked on body
- * Mounting: position: Any
- * Weight: 4.8 grams

MAXIMUM RATINGS AND ELECTRICAL CHARACTERISTICS

Ratings at 25 °C ambient temperature unless otherwise specified.
Single phase, half wave, 60 Hz, resistive or inductive load.
For capacitive load, derate current by 20%.

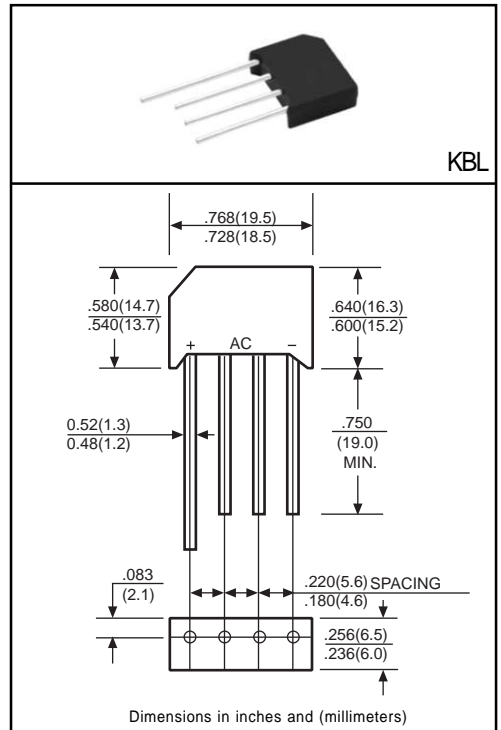

	SYMBOL	KBL005	KBL01	KBL02	KBL04	KBL06	KBL08	KBL10	UNITS
Maximum Recurrent Peak Reverse Voltage	VRRM	50	100	200	400	600	800	1000	Volts
Maximum RMS Bridge Input Voltage	VRMS	35	70	140	280	420	560	700	Volts
Maximum DC Blocking Voltage	VDC	50	100	200	400	600	800	1000	Volts
Maximum Average Forward Output Current at T _A = 100°C	I _O	4.0							Amps
Peak Forward Surge Current 8.3 ms single half sine-wave superimposed on rated load (JEDEC Method)	I _{FSM}	150							Amps
Maximum Forward Voltage Drop per element at 4.0 A DC	V _F	1.1							Volts
Maximum DC Reverse Current at Rated DC Blocking Voltage per element	I _R	@T _J = 25°C							uAmps
		@T _J = 100°C							
I ² t Rating for Fusing (t<8.3ms)	I ² t	93							A ² Sec
Typical Junction Capacitance (Note1)	C _J	15							pF
Typical Thermal Resistance (Note 2)	R _{θJA}	40							°C/W
Operating Temperature Range	T _J	-55 to + 150							°C
Storage Temperature Range	T _{STG}	-55 to + 150							°C

NOTES : 1.Measured at 1 MHz and applied reverse voltage of 4.0 volts
2.Thermal Resistance from Junction to Ambient with units mounted on 3.0x3.0x0.11"(7.5x7.3x0.3cm)AL plate .

RATING AND CHARACTERISTIC CURVES (KBL005 THRU KBL10 RS401 THRU RS407)

FIG. 1 - MAXIMUM NON-REPETITIVE FORWARD SURGE CURRENT

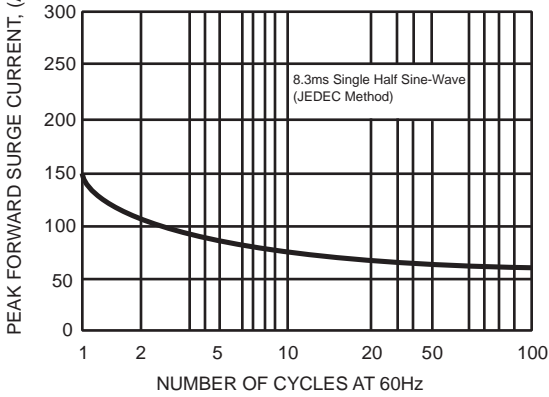

FIG. 2 - TYPICAL FORWARD CURRENT DERATING CURVE

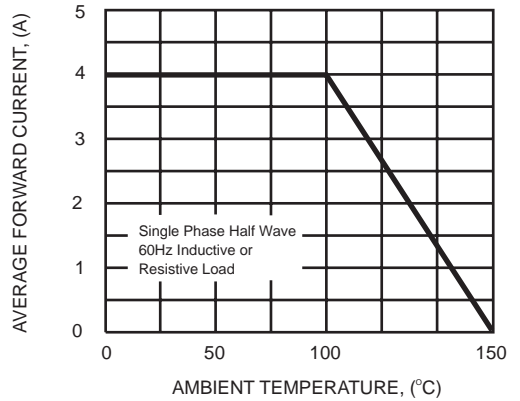

FIG. 3 - TYPICAL INSTANTANEOUS FORWARD CHARACTERISTICS

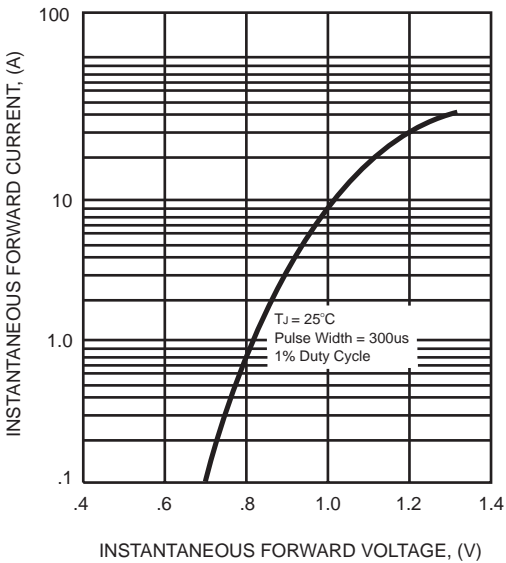

FIG. 4 - TYPICAL REVERSE CHARACTERISTICS

