

Camelion LR1-Plus

PLUS ALKALINE BATTERY

Dimensions

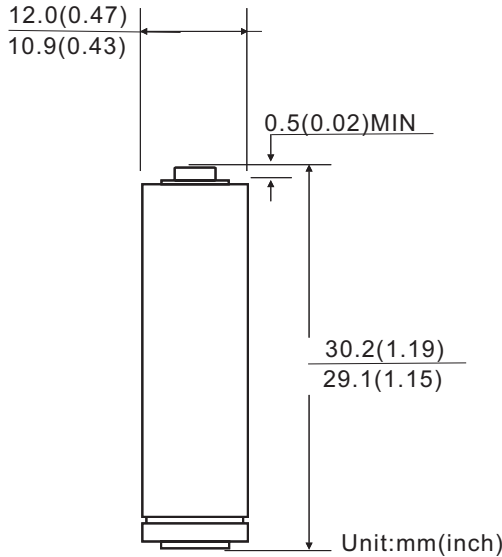

Specifications

Chemical System : Alkaline
 Zinc-Manganese Dioxide (Zn/MnO₂)
Camelion Model : LR1
IEC No. : LR1
ANSI/NEDA No. : 910A (N)
Average Weight : 8.5g
Dimension (∅ x H) : 11.45^{±0.55} x 29.65^{±0.55} mm
 0.45^{±0.02} x 1.17^{±0.02} inch
Terminals : Flat
Nominal Voltage : 1.5Volts
Average Capacity : 750 mAh to 0.8 volts
 (20±2 , Rated capacity at 25 mA continuous drain)
Jacket : Aluminum Foil Label

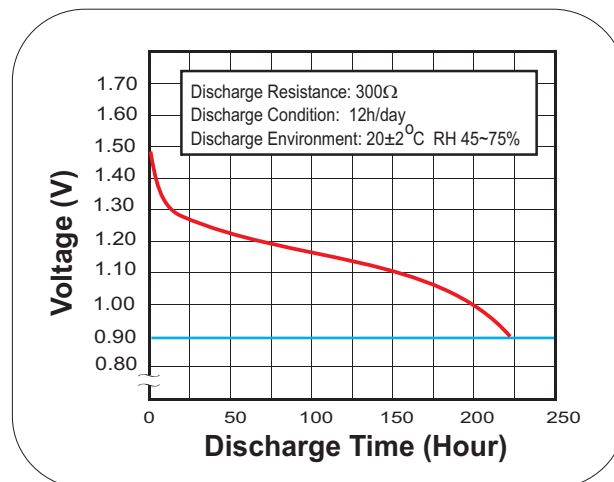
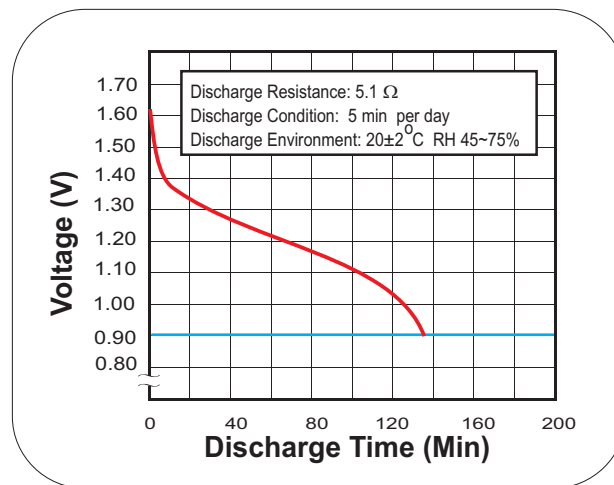

Notice:

Environmental elements comply with RoHS requirements. This information is subject to change without prior notice and for reference only. It should not be used as a basis for a product guarantee or warranty. For additional information, please consult your nearest Camelion Sales Office or Distributor or visit our website at: www.camelionbattery.com.