

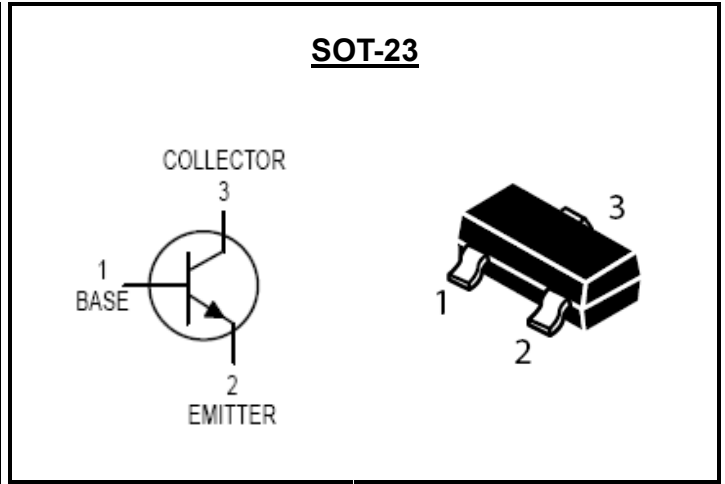
<b>NPN GENERAL PURPOSE TRANSISTOR</b>	<b>REVERSE VOLTAGE – 300 Volts FORWARD CURRENT – 0.5 Amperes</b>
---------------------------------------	--

**FEATURES**

- Surface mount device
- Simplifies circuit design
- Reduces board space and component count
- Complementary PNP type available (MMBTA92)

**MECHANICAL DATA**

- Case: SOT-23 plastic
- Lead Free in RoHS 2002/95/EC Compliant
- Case material: “Green” molding compound, UL flammability classification 94V-0, (No Br. Sb. Cl)



**MAXIMUM RATINGS AND ELECTRICAL CHARACTERISTICS**  
Ratings at 25°C ambient temperature unless otherwise specified.

**ABSOLUTE RATINGS**

PARAMETER	SYMBOL	VALUE	UNIT
Collector-emitter voltage	$V_{CEO}$	300	Vdc
Collector-base voltage	$V_{CBO}$	300	Vdc
Emitter-base voltage	$V_{EBO}$	6.0	Vdc
Collector current-continuous	$I_C$	500	mAdc

**THERMAL CHARACTERISTICS**

PARAMETER	SYMBOL	MAX	UNIT
Total device dissipation FR-5 board (Note 1) @ $T_A = 25^\circ\text{C}$	$P_D$	225	mW
Thermal resistance junction to ambient	$R_{thJA}$	556	$^\circ\text{C/W}$
Total device dissipation alumina substrate (Note 2) @ $T_A = 25^\circ\text{C}$	$P_D$	300	mW
Thermal resistance junction to ambient	$R_{thJA}$	417	$^\circ\text{C/W}$
Junction and storage temperature rang	$T_J, T_{STG}$	-55 to +150	$^\circ\text{C}$

**Note:**  
 1. FR-5 = 1.0 \* 0.75 \* 0.062 in.  
 2. Alumina = 0.4 \* 0.3 \* 0.024 in 99.5% alumina.

**REV-1, OCT.-2015, KSNR24**

**ORDERING INFORMATION**

DEVICE	MARKING	SHIPPING
MMBTA42	1D	3000/ Tape & Reel

**OFF CHARACTERISTICS** (Note 3)

PARAMETER	TEST CONDITION	SYMBOL	MIN.	MAX	UNIT
Collector-emitter breakdown voltage	$I_C = 1.0 \text{ mAdc}, I_B = 0$	$V_{(BR)CEO}$	300	--	Vdc
Collector-base breakdown voltage	$I_C = 100 \text{ uAdc}, I_E = 0$	$V_{(BR)CBO}$	300	--	Vdc
Emitter-base breakdown voltage	$I_E = 100 \text{ uAdc}, I_C = 0$	$V_{(BR)EBO}$	6.0	--	Vdc
Collector cutoff current	$V_{CB} = 200 \text{ Vdc}, I_E = 0$	$I_{CBO}$	--	0.1	$\mu\text{Adc}$
Emitter cutoff current	$V_{EB} = 6.0 \text{ Vdc}, I_C = 0$	$I_{EBO}$	--	0.1	$\mu\text{Adc}$

**ON CHARACTERISTICS** (Note 3)

PARAMETER	TEST CONDITION	SYMBOL	MIN.	MAX	UNIT
DC current gain	$I_C = 1.0 \text{ mAdc}, V_{CE} = 10 \text{ Vdc}$	$h_{FE}$	25	--	--
	$I_C = 10 \text{ mAdc}, V_{CE} = 10 \text{ Vdc}$		40	--	
	$I_C = 30 \text{ mAdc}, V_{CE} = 10 \text{ Vdc}$		40	--	
Collector-emitter saturation voltage	$I_C = 20 \text{ mAdc}, I_B = 2.0 \text{ mAdc}$	$V_{CE(SAT)}$	--	0.5	Vdc
Base-emitter saturation voltage	$I_C = 20 \text{ mAdc}, I_B = 2.0 \text{ mAdc}$	$V_{BE(SAT)}$	--	0.9	Vdc

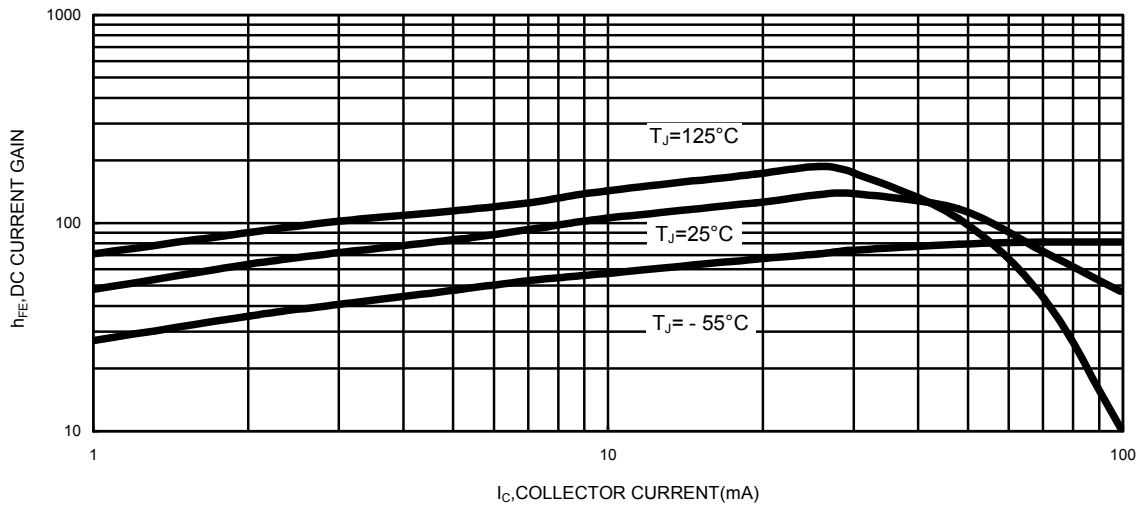
**SMALL – SIGNAL CHARACTERISTICS**

PARAMETER	TEST CONDITION	SYMBOL	MIN.	MAX	UNIT
Current-gain-bandwidth product	$I_C = 10 \text{ mAdc}, V_{CE} = 20 \text{ Vdc}, f = 100 \text{ MHz}$	$f_T$	50	--	MHz
Current-base capacitance	$I_E = 0, V_{CB} = 20 \text{ Vdc}, f = 1.0 \text{ MHz}$	$C_{Cb}$	--	3.0	pF

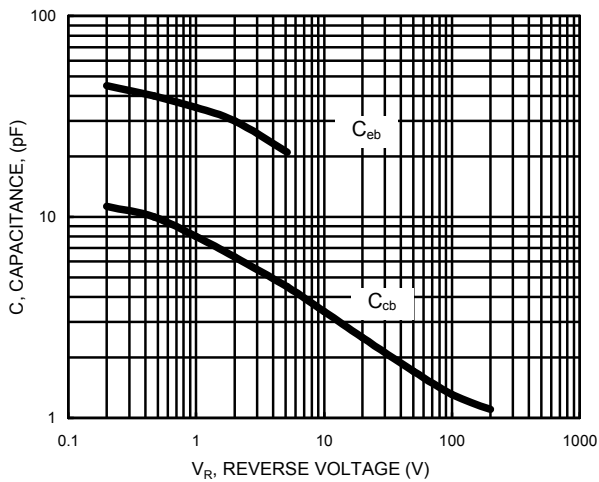
**Note:**

 3. Pulse Test: pulse width  $\leq 300 \mu\text{s}$ , duty cycle  $\leq 2.0\%$

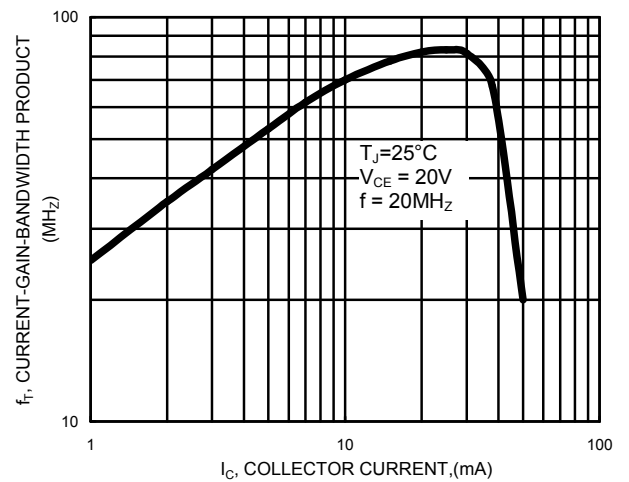
**FIG.1 - DC current gain**



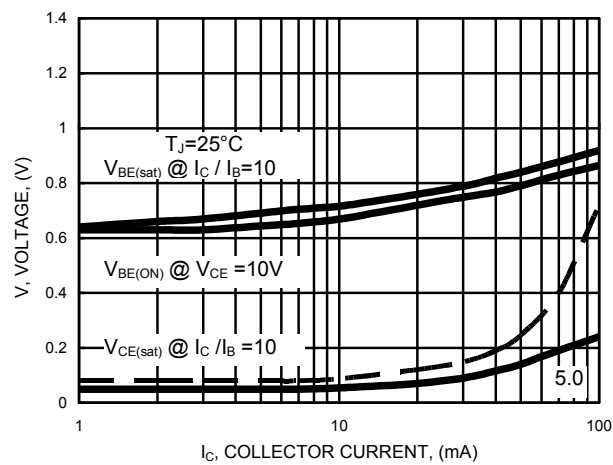
**FIG.2 - Capacitance**



**FIG.3 - Current-gain-bandwidth product**

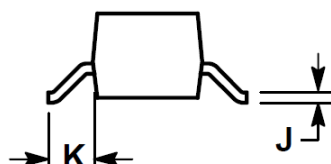
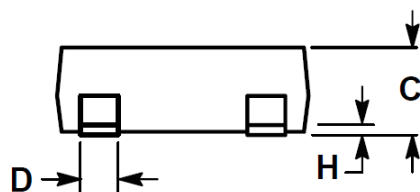
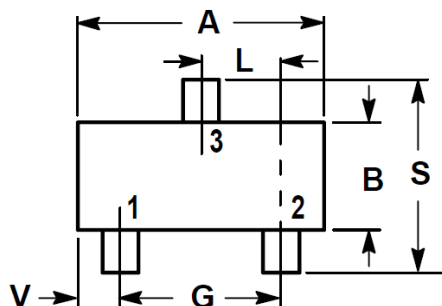


**FIG.4 - On voltages**



Package Dimensions :

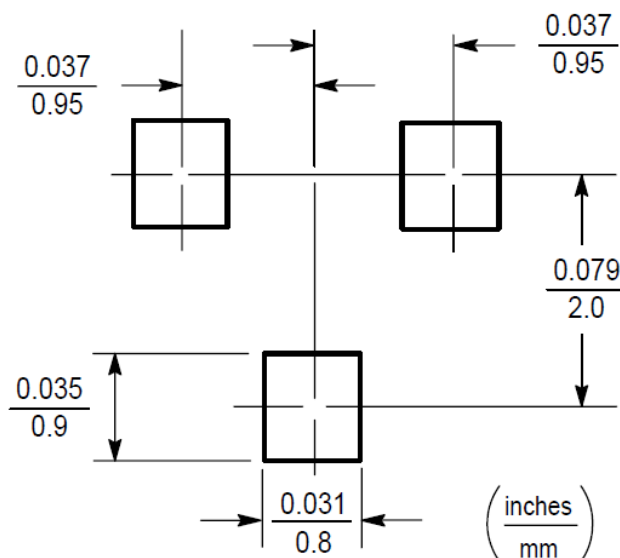
**SOT-23**



Dim.	INCHES		MILLIMETERS	
	Min.	Max.	Min.	Max.
A	0.1102	0.1197	2.80	3.04
B	0.0472	0.0551	1.20	1.40
C	0.0350	0.0440	0.89	1.11
D	0.0150	0.0200	0.37	0.50
G	0.0701	0.0807	1.78	2.04
H	0.0005	0.0040	0.013	0.100
J	0.0034	0.0070	0.085	0.177
K	0.0140	0.0285	0.35	0.69
L	0.0350	0.0401	0.89	1.02
S	0.0830	0.1039	2.10	2.64
V	0.0177	0.0236	0.45	0.60

- PIN:  
 1. BASE  
 2. EMITTER  
 3. COLLECTOR

Recommended Footprint :



### **Important Notice and Disclaimer**

LSC reserves the right to make changes to this document and its products and specifications at any time without notice. Customers should obtain and confirm the latest product information and specifications before final design, purchase or use.

LSC makes no warranty, representation or guarantee regarding the suitability of its products for any particular purpose, nor does LSC assume any liability for application assistance or customer product design. LSC does not warrant or accept any liability with products which are purchased or used for any unintended or unauthorized application.

No license is granted by implication or otherwise under any intellectual property rights of LSC.

LSC products are not authorized for use as critical components in life support devices or systems without express written approval of LSC.