

Total solder points: 159

Difficulty level:

beginner 1 2 3 4 5 advanced

High-Q
velleman-kit 

4 channel recorder / logger

Hardware:

K8047

- USB connected and powered.
- Four DC coupled input channels.
- Input resistance 1Mohm.
- Maximum samples per second : 100
- Four input ranges, 3V / 6V / 15V and 30V.
- Sensitivity 10mV.
- Accuracy $\pm 3\%$ of full scale.
- Maximum input 30Vdc.
- Power and recording/diagnostic LED indication on unit.

Software:

- Analogue trace or digital DVM readout.
- 4 simultaneous channels recording.
- Minimum / maximum sample hold function for DVM.
- From 1 sec to 1000 sec per division.
- Storage and recall of screens (full colour) or data.
- Automatic recording option for long time recordings.
- On screen markers for time and voltage.
- DLL included for own development.







VELLEMAN Components NV
Legen Heirweg 33
9890 Gavere
Belgium Europe
www.velleman.be
www.velleman-kit.com

1. Assembly (Skipping this can lead to troubles !)

Ok, so we have your attention. These hints will help you to make this project successful. Read them carefully.

1.1 Make sure you have the right tools:

- A good quality soldering iron (25-40W) with a small tip. 
- Wipe it often on a wet sponge or cloth, to keep it clean; then apply solder to the tip, to give it a wet look. This is called 'thinning' and will protect the tip, and enables you to make good connections. When solder rolls off the tip, it needs cleaning.
- Thin rosin-core solder. Do not use any flux or grease. 
- A diagonal cutter to trim excess wires. To avoid injury when cutting excess leads, hold the lead so they cannot fly towards the eyes. 
- Needle nose pliers, for bending leads, or to hold components in place. 
- Small blade and Phillips screwdrivers. A basic range is fine.



For some projects, a basic multi-meter is required, or might be handy

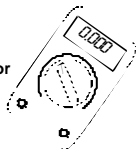

1.2 Assembly Hints :

- ⇒ Make sure the skill level matches your experience, to avoid disappointments.
- ⇒ Follow the instructions carefully. Read and understand the entire step before you perform each operation.
- ⇒ Perform the assembly in the correct order as stated in this manual
- ⇒ Position all parts on the PCB (Printed Circuit Board) as shown on the drawings.
- ⇒ Values on the circuit diagram are subject to changes.
- ⇒ Values in this assembly guide are correct*
- ⇒ Use the checkboxes to mark your progress.
- ⇒ Please read the included information on safety and customer service

* Typographical inaccuracies excluded. Always look for possible last minute manual updates, indicated as 'NOTE' on a separate leaflet.

1.3 Soldering Hints :

Mount the component against the PCB surface and carefully solder the leads

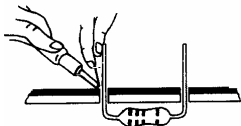

Make sure the solder joints are cone-shaped and shiny



Trim excess leads as close as possible to the solder joint

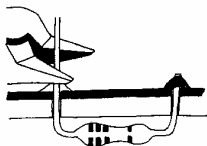

AXIAL COMPONENTS ARE TAPED IN THE CORRECT MOUNTING SEQUENCE !

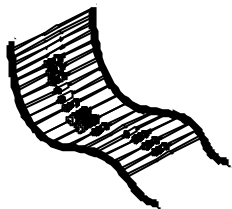

REMOVE THEM FROM THE TAPE ONE AT A TIME !

5%



*K7= (P - 7 - 2 - B)



*K7= (P - 7 - 2 - B)

COLOR= 2...5



	I	P	E	SF	S	DK	N	D	GB	F	NL
C	CODICE	CODIGO	CODIGO	VÄRI	FÄRG	FARVE-	FARGE-	FARB	COLOUR	CODIFI-	KLEUR
O	COLORE	DE CORES	DE COL-	KOODI	SCHEMA	KODE	KODE	KODE	CODE	CATION	KODE
D		ORES	ORES							DES COU-	D
E									LEURS	LEURS	E
0	Nero	Preto	Negro	Musta	Svart	Sort	Sort	Schwarz	Black	Noir	Zwart
1	Marrone	Castanho	Marrón	Ruskea	Brun	Brun	Brun	Braun	Brown	Brun	Bruin
2	Rosso	Encarnado Rojo		Punainen	Röd	Rød	Rød	Rot	Red	Rouge	Rood
3	Aranciato	Laranja	Naranja	Oranssi	Orange	Orange	Orange	Orange	Orange	Orange	Oranje
4	Giallo	Amarelo	Amarillo	Keitainen	Gul	Gul	Gul	Gelb	Yellow	Jaune	Geel
5	Verde	Verde	Verde	Vihreä	Grön	Grøn	Grønn	Grün	Green	Vert	Groen
6	Blu	Azul	Azul	Sininen	Blå	Blå	Blå	Blau	Blue	Bleu	Blauw
7	Viola	Violeta	Morado	Purppura	Lila	Violet	Violet	Violet	Purple	Violet	Paars
8	Grigio	Cinzeno	Gris	Harmaa	Grå	Grå	Grå	Grau	Grey	Gris	Grijs
9	Bianco	Branco	Blanco	Valkoinen	Vit	Hvid	Hvidt	Weiss	White	Blanc	Wit
A	Argento	Prateado	Plata	Hopea	Silver	Sølv	Sølv	Silber	Silver	Argent	Zilver
B	Oro	Dourado	Oro	Kulta	Guld	Guld	Guldi	Gold	Gold	Or	Goud

1. Jumper

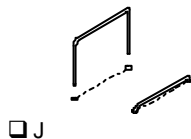

J

2. Resistors

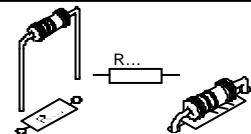

- R1 : 1K5 (1-5-2-B)
- R2 : 3K (3-0-0-1-1)
- R3 : 6K8 (6-8-0-1-1)
- R4 : 27K (2-7-0-2-1)
- R5 : 91K (9-1-0-2-1)
- R6 : 1M (1-0-0-4-1)
- R7 : 91K (9-1-0-2-1)
- R8 : 1M (1-0-0-4-1)
- R9 : 27K (2-7-0-2-1)
- R10 : 470E (4-7-1-B)
- R11 : 6K8 (6-8-0-1-1)
- R12 : 27K (2-7-0-2-1)
- R13 : 27K (2-7-0-2-1)
- R14 : 91K (9-1-0-2-1)
- R15 : 91K (9-1-0-2-1)
- R16 : 1M (1-0-0-4-1)
- R17 : 1M (1-0-0-4-1)
- R18 : 1K5 (1-5-2-B)
- R19 : 27K (2-7-0-2-1)
- R20 : 6K8 (6-8-0-1-1)
- R21 : 3K (3-0-0-1-1)
- R22 : 3K (3-0-0-1-1)
- R23 : 1K5 (1-5-2-B)

- R24 : 27K (2-7-0-2-1)
- R25 : 1K5 (1-5-2-B)
- R26 : 27K (2-7-0-2-1)
- R27 : 6K8 (6-8-0-1-1)
- R28 : 3K (3-0-0-1-1)
- R29 : 27K (2-7-0-2-1)
- R30 : 1K5 (1-5-2-B)
- R31 : 470E (4-7-1-B)
- R32 : 1K5 (1-5-2-B)

3. IC sockets. Watch the position of the notch!

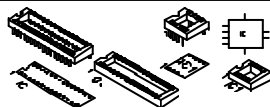

- IC1 : 28p
- IC2 : 14p

4. Ceramic Capacitors

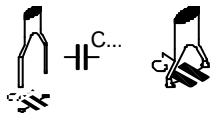

- C1 : 220nF (224, 0.22)
- C2 : 33pF (33)
- C3 : 33pF (33)
- C4 : 100nF (104, 0.1, u1)
- C6 : 100nF (104, 0.1, u1)
- C7 : 100nF (104, 0.1, u1)
- C8 : 100nF (104, 0.1, u1)
- C9 : 100nF (104, 0.1, u1)
- C10 : 100nF (104, 0.1, u1)
- C11 : 100nF (104, 0.1, u1)

5. Zenerdiode

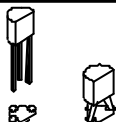

ZD1 : LM385Z

6. Quartz crystal

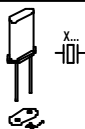

X1 : 6MHz

7. Screw connectors

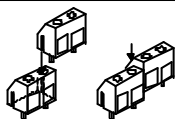

J1 : 2P (CH1)
 J2 : 2P (CH2)
 J3 : 2P (CH3)
 J4 : 2P (CH4)

8. USB connector

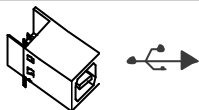

J5 : USB B90

9. Electrolytic capacitors. Check the polarity !

C5 : 4,7 μ F / 50V

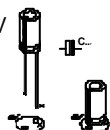

10. LED's. Watch the polarity!

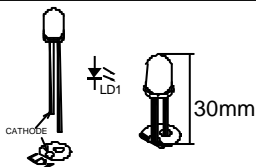

LD1 : 3mm
 'Red' => Recording
 LD2 : 3mm
 'Green' => Power ON

11. IC's. Watch the position of the notch!

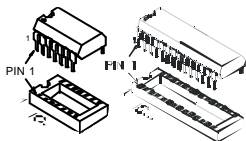

IC1 : VK8047
 Programmed PIC16C745-IP !
 IC2 : TLV274IP

12. Software installation and test



DO NOT CLOSE THE HOUSING YET

&



DO NOT ATTACH THE FRONT STICKER YET

A. Installation :

- Install the software. If the necessary software is not included or if you want to check for updates, you can always download it for free from our Velleman Website www.velleman.be
- An installation wizard will guide you through the installation procedure.
- By default the software is installed in the folder :
'C:\Program Files\Velleman\Pc-Lab2000'



Fig 1.0

B. Test :

- Hook-up a USB cable between a free port of your computer and the K8047 (see page 8.)
- Connect a 9V battery to one of the signal inputs (CH1, CH2, CH3 or CH4), respect the polarity (+ and -)!
- Start the PC-Lab2000 software and select the appropriate device (K8047).

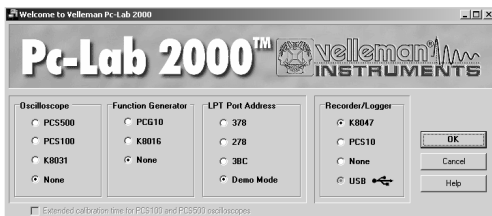



Fig 2.0

- Select 15 or 30V range.
- Press the run button.

The unit is ready for use when a signal appears on the screen.

 Other information concerning this unit can be found on the CD.

13. Final assembly

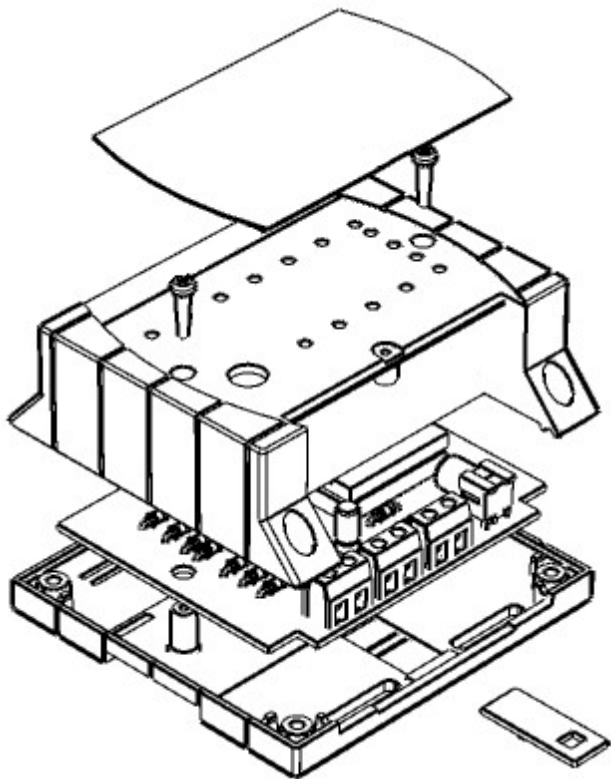

You can close the housing and affix the front sticker after the final test.

14. Connection

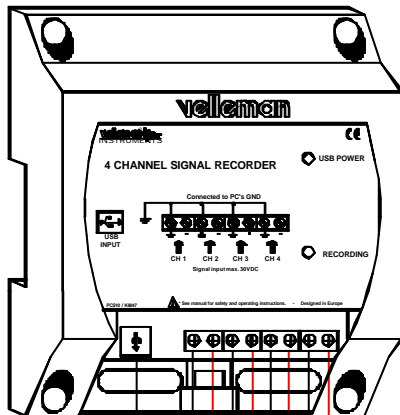

👉 Inspect the assembly once more

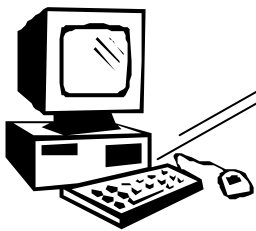

USB CABLE - A MALE TO B MALE

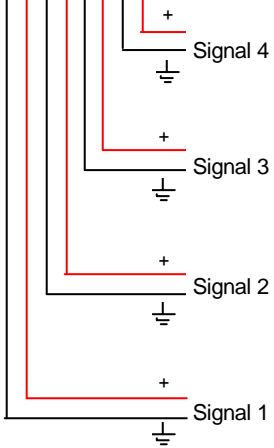

**PCB
&
DIAGRAM**

15. PCB layout.

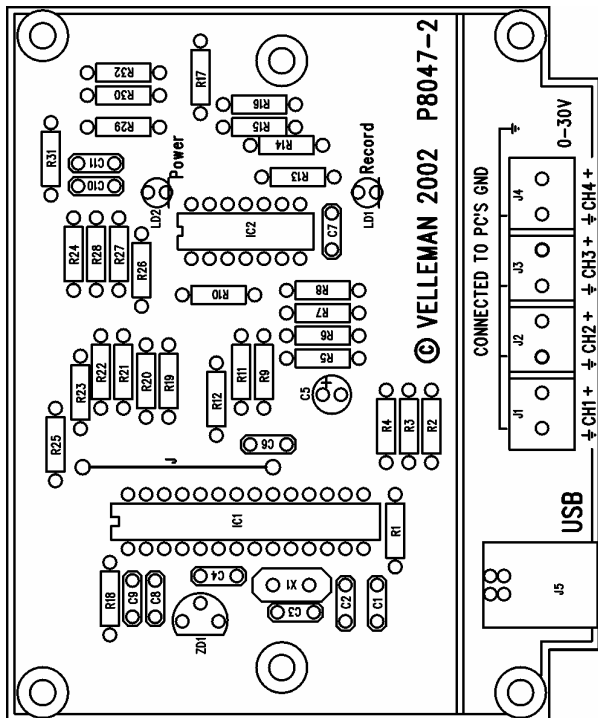

16. Schematic diagram.

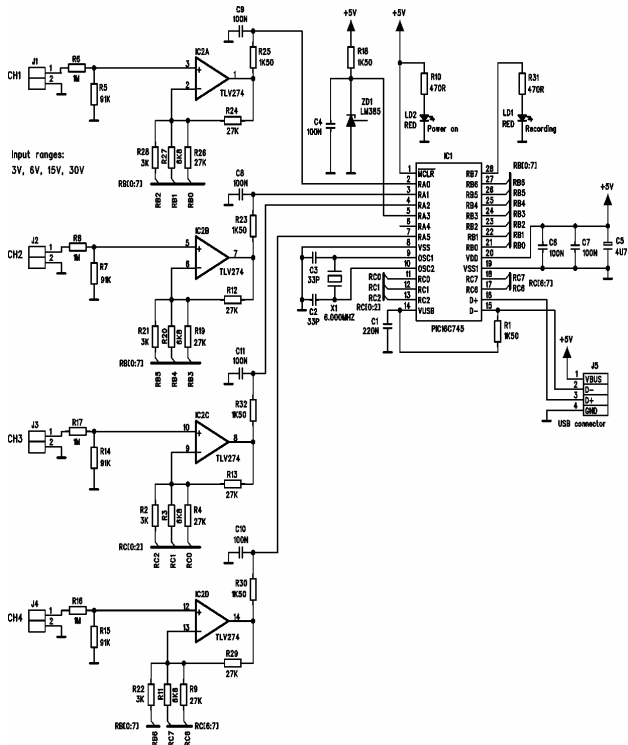

Notes :

Modifications and typographical errors reserved
© Velleman Components nv.
H8047IP - 2003 - ED1