



# HCF4008B

## 4 BIT FULL ADDER WITH PARALLEL CARRY OUTPUT

- HIGH SPEED OPERATION :  
SUM IN TO SUM OUT 160ns (Typ.)  
CARRY IN TO CARRY OUT 50ns (Typ.)  
at  $V_{DD} = 10V$  ,  $C_L = 50pF$
- 4 SUM OUTPUTS PLUS PARALLEL LOOK-AHEAD CARRY OUTPUT
- QUIESCENT CURRENT SPECIFIED UP TO 20V
- 5V, 10V AND 15V PARAMETRIC RATINGS
- INPUT LEAKAGE CURRENT  
 $I_l = 100nA$  (MAX) AT  $V_{DD} = 18V$   $T_A = 25^\circ C$
- 100% TESTED FOR QUIESCENT CURRENT
- MEETS ALL REQUIREMENTS OF JEDEC JESD13B " STANDARD SPECIFICATIONS FOR DESCRIPTION OF B SERIES CMOS DEVICES"

### DESCRIPTION

The HCF4008B is a monolithic integrated circuit fabricated in Metal Oxide Semiconductor technology available in DIP and SOP packages. The HCF4008B consists of four full adder stages with fast look ahead carry provision from stage to

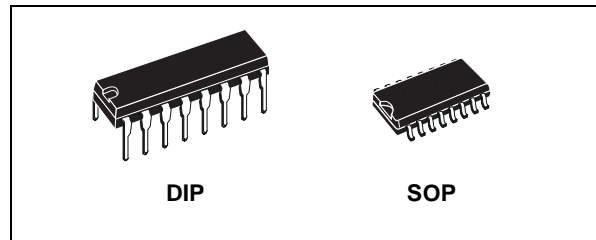

### ORDER CODES

PACKAGE	TUBE	T & R
DIP	HCF4008BEY	
SOP	HCF4008BM1	HCF4008M013TR

stage. Circuitry is included to provide a fast "parallel carry out" to permit high speed operation in arithmetic sections using several HCF4008B's. HCF4008B inputs include the four sum bits, S1 to S4. In addition to the high speed "parallel carry out" which may be utilized at a succeeding HCF4008B section.

### PIN CONNECTION

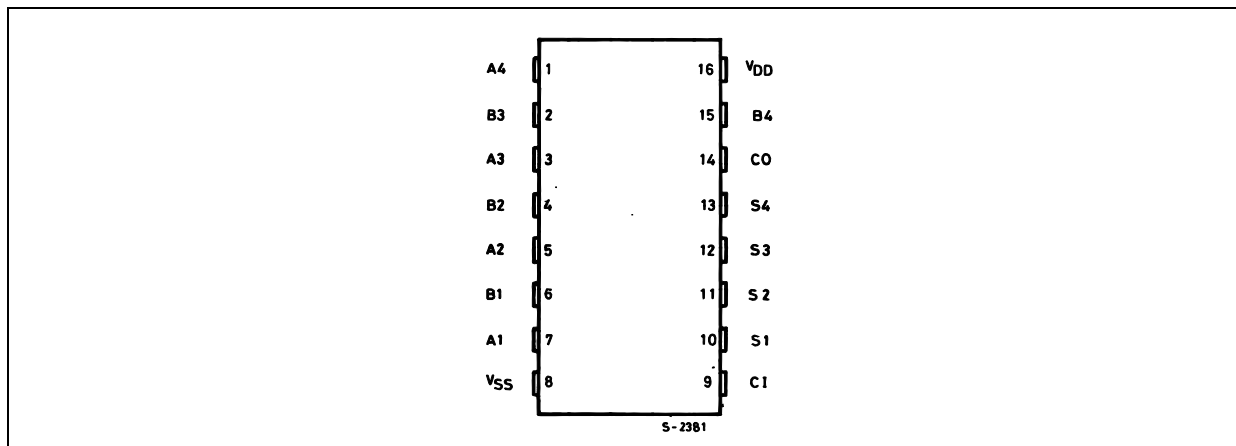

# HCF4008B

## IINPUT EQUIVALENT CIRCUIT



## PIN DESCRIPTION

PIN No	SYMBOL	NAME AND FUNCTION
7, 5, 3, 1	A1 to A4	A Operand Inputs
6, 4, 2, 15	B1 to B4	B Operand Inputs
10, 11, 12, 13	S1 to S4	Sum Outputs
9	CI	Carry In
14	CO	Carry Out
8	V <sub>SS</sub>	Negative Supply Voltage
16	V <sub>DD</sub>	Positive Supply Voltage

## TRUTH TABLE

A <sub>n</sub>	B <sub>n</sub>	CI	CO	SUM
L	L	L	L	L
H	L	L	L	H
L	H	L	L	H
H	H	L	H	L
L	L	H	L	H
H	L	H	H	L
L	H	H	H	L
H	H	H	H	H

X : Don't Care

## LOGIC DIAGRAM

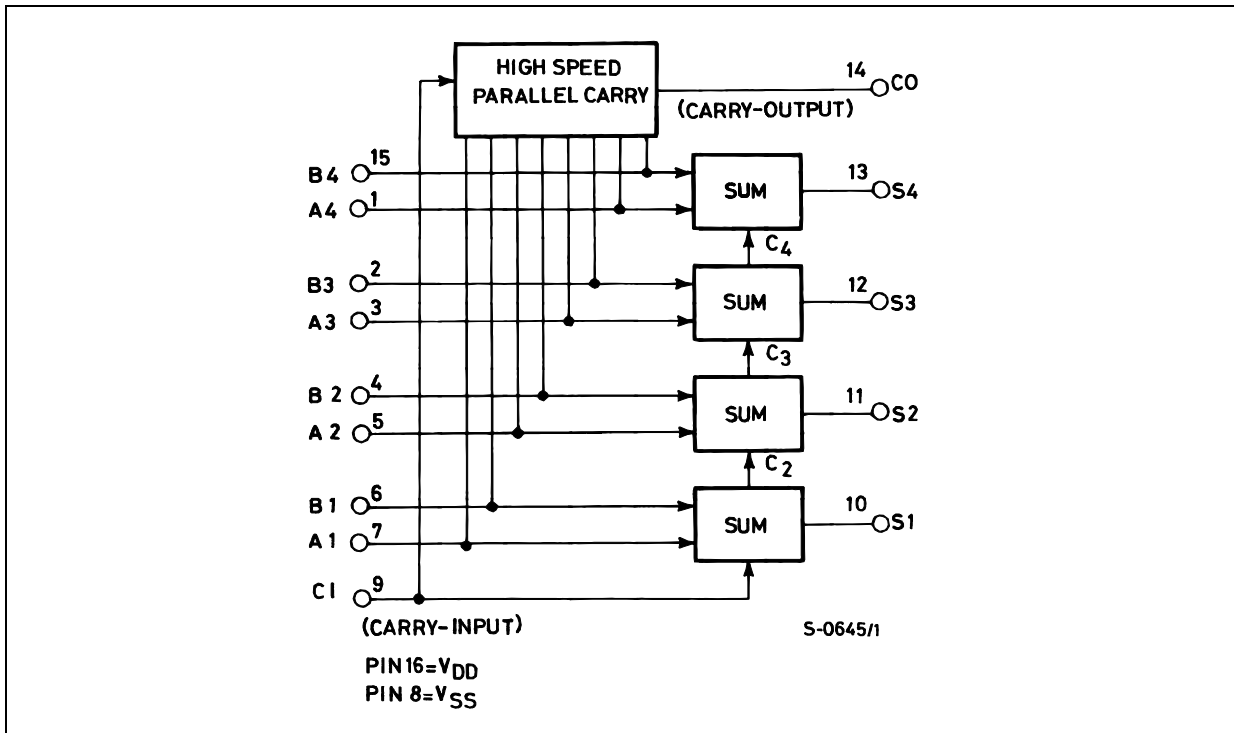

**ABSOLUTE MAXIMUM RATINGS**

Symbol	Parameter	Value	Unit
$V_{DD}$	Supply Voltage	-0.5 to +22	V
$V_I$	DC Input Voltage	-0.5 to $V_{DD} + 0.5$	V
$I_I$	DC Input Current	$\pm 10$	mA
$P_D$	Power Dissipation per Package	200	mW
	Power Dissipation per Output Transistor	100	mW
$T_{op}$	Operating Temperature	-55 to +125	°C
$T_{stg}$	Storage Temperature	-65 to +150	°C

Absolute Maximum Ratings are those values beyond which damage to the device may occur. Functional operation under these conditions is not implied.

All voltage values are referred to  $V_{SS}$  pin voltage.

**RECOMMENDED OPERATING CONDITIONS**

Symbol	Parameter	Value	Unit
$V_{DD}$	Supply Voltage	3 to 20	V
$V_I$	Input Voltage	0 to $V_{DD}$	V
$T_{op}$	Operating Temperature	-55 to 125	°C

## DC SPECIFICATIONS

Symbol	Parameter	Test Condition				Value						Unit	
		V <sub>I</sub> (V)	V <sub>O</sub> (V)	I <sub>oI</sub>   ( $\mu$ A)	V <sub>DD</sub> (V)	T <sub>A</sub> = 25°C			-40 to 85°C		-55 to 125°C		
						Min.	Typ.	Max.	Min.	Max.	Min.		Max.
I <sub>L</sub>	Quiescent Current	0/5			5		0.04	5		150		150	$\mu$ A
		0/10			10		0.04	10		300		300	
		0/15			15		0.04	20		600		600	
		0/20			20		0.08	100		3000		3000	
V <sub>OH</sub>	High Level Output Voltage	0/5		<1	5	4.95			4.95		4.95		V
		0/10		<1	10	9.95			9.95		9.95		
		0/15		<1	15	14.95			14.95		14.95		
V <sub>OL</sub>	Low Level Output Voltage	5/0		<1	5		0.05			0.05		0.05	V
		10/0		<1	10		0.05			0.05		0.05	
		15/0		<1	15		0.05			0.05		0.05	
V <sub>IH</sub>	High Level Input Voltage		0.5/4.5	<1	5	3.5			3.5		3.5		V
			1/9	<1	10	7			7		7		
			1.5/13.5	<1	15	11			11		11		
V <sub>IL</sub>	Low Level Input Voltage		4.5/0.5	<1	5			1.5		1.5		1.5	V
			9/1	<1	10			3		3		3	
			13.5/1.5	<1	15			4		4		4	
I <sub>OH</sub>	Output Drive Current	0/5	2.5	<1	5	-1.36	-3.2		-1.1		-1.1		mA
		0/5	4.6	<1	5	-0.44	-1		-0.36		-0.36		
		0/10	9.5	<1	10	-1.1	-2.6		-0.9		-0.9		
		0/15	13.5	<1	15	-3.0	-6.8		-2.4		-2.4		
I <sub>OL</sub>	Output Sink Current	0/5	0.4	<1	5	0.44	1		0.36		0.36		mA
		0/10	0.5	<1	10	1.1	2.6		0.9		0.9		
		0/15	1.5	<1	15	3.0	6.8		2.4		2.4		
I <sub>I</sub>	Input Leakage Current	0/18	Any Input		18		$\pm 10^{-5}$	$\pm 0.1$		$\pm 1$		$\pm 1$	$\mu$ A
C <sub>I</sub>	Input Capacitance		Any Input				5	7.5					pF

The Noise Margin for both "1" and "0" level is: 1V min. with V<sub>DD</sub>=5V, 2V min. with V<sub>DD</sub>=10V, 2.5V min. with V<sub>DD</sub>=15V

**DYNAMIC ELECTRICAL CHARACTERISTICS** ( $T_{amb} = 25^{\circ}C$ ,  $C_L = 50pF$ ,  $R_L = 200K\Omega$ ,  $t_r = t_f = 20 ns$ )

Symbol	Parameter	Test Condition		Value (*)			Unit
		$V_{DD}$ (V)		Min.	Typ.	Max.	
$t_{PLH}$ $t_{PHL}$	Propagation Delay Time (SUM IN to SUM OUT)	5			400	800	ns
		10			160	320	
		15			115	230	
$t_{PLH}$ $t_{PHL}$	Propagation Delay Time (CARRY IN to SUM OUT)	5			370	740	ns
		10			155	310	
		15			115	230	
$t_{PLH}$ $t_{PHL}$	Propagation Delay Time (SUM IN to CARRY OUT)	5			200	400	ns
		10			90	180	
		15			65	130	
$t_{PLH}$ $t_{PHL}$	Propagation Delay Time (CARRY IN to CARRY OUT)	5			100	200	ns
		10			50	100	
		15			40	80	
$t_{THL}$ $t_{TLH}$	Transition Time (carry out or decoded out lines)	5			100	200	ns
		10			50	100	
		15			40	80	

(\*) Typical temperature coefficient for all  $V_{DD}$  value is 0.3 %/°C.

**TYPICAL APPLICATION**

**SPEED CHARACTERISTICS OF A 16 BIT-ADDER**

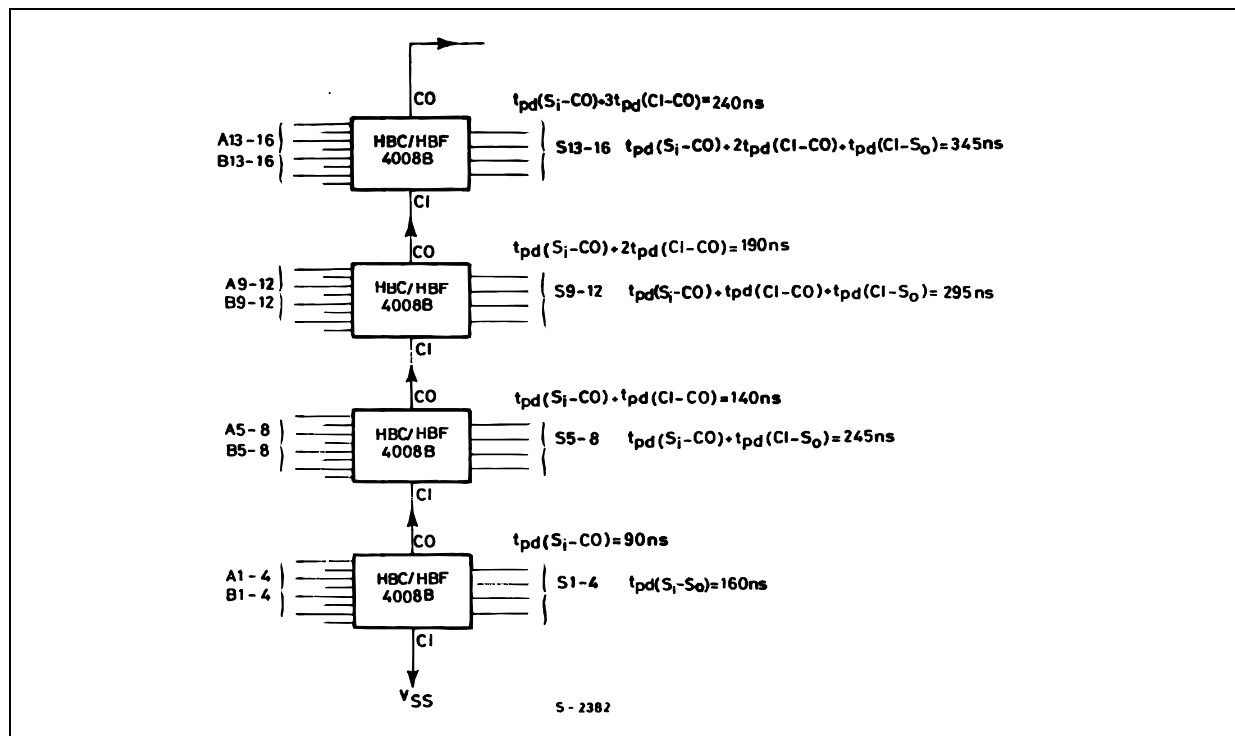

NOTES : All "A" and "B" input bits occur at  $t = 0$   
 All sums settled at  $t = 345 ns$   
 $C_L = 50pF$ ,  $T_{amb} = 25^{\circ}C$ ,  $V_{DD} - V_{SS} = 10V$

TEST CIRCUIT

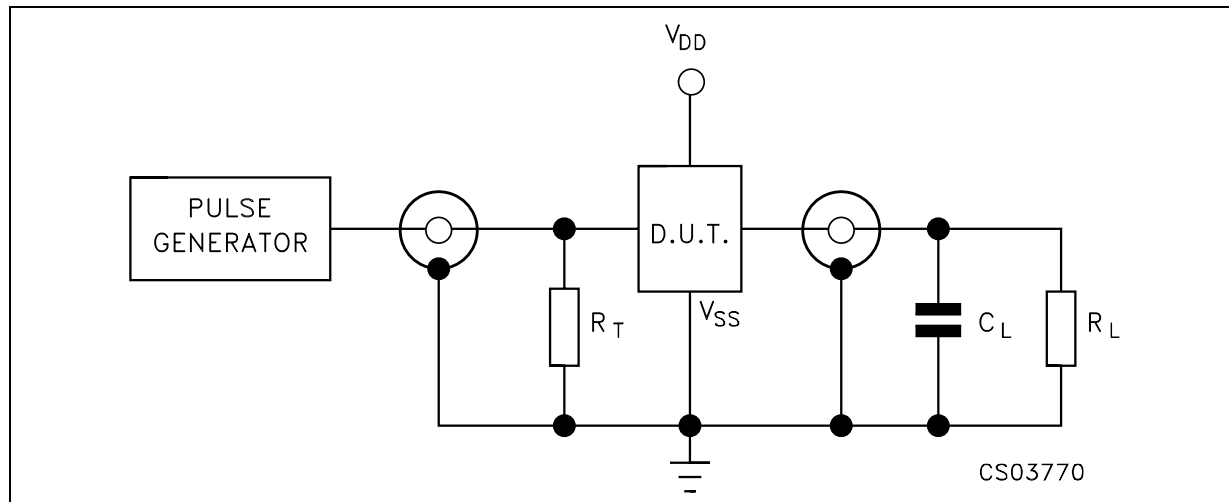

C<sub>L</sub> = 50pF or equivalent (includes jig and probe capacitance)  
R<sub>L</sub> = 200KΩ  
R<sub>T</sub> = Z<sub>OUT</sub> of pulse generator (typically 50Ω)

### Plastic DIP-16 (0.25) MECHANICAL DATA

DIM.	mm.			inch		
	MIN.	TYP	MAX.	MIN.	TYP.	MAX.
a1	0.51			0.020		
B	0.77		1.65	0.030		0.065
b		0.5			0.020	
b1		0.25			0.010	
D			20			0.787
E		8.5			0.335	
e		2.54			0.100	
e3		17.78			0.700	
F			7.1			0.280
I			5.1			0.201
L		3.3			0.130	
Z			1.27			0.050

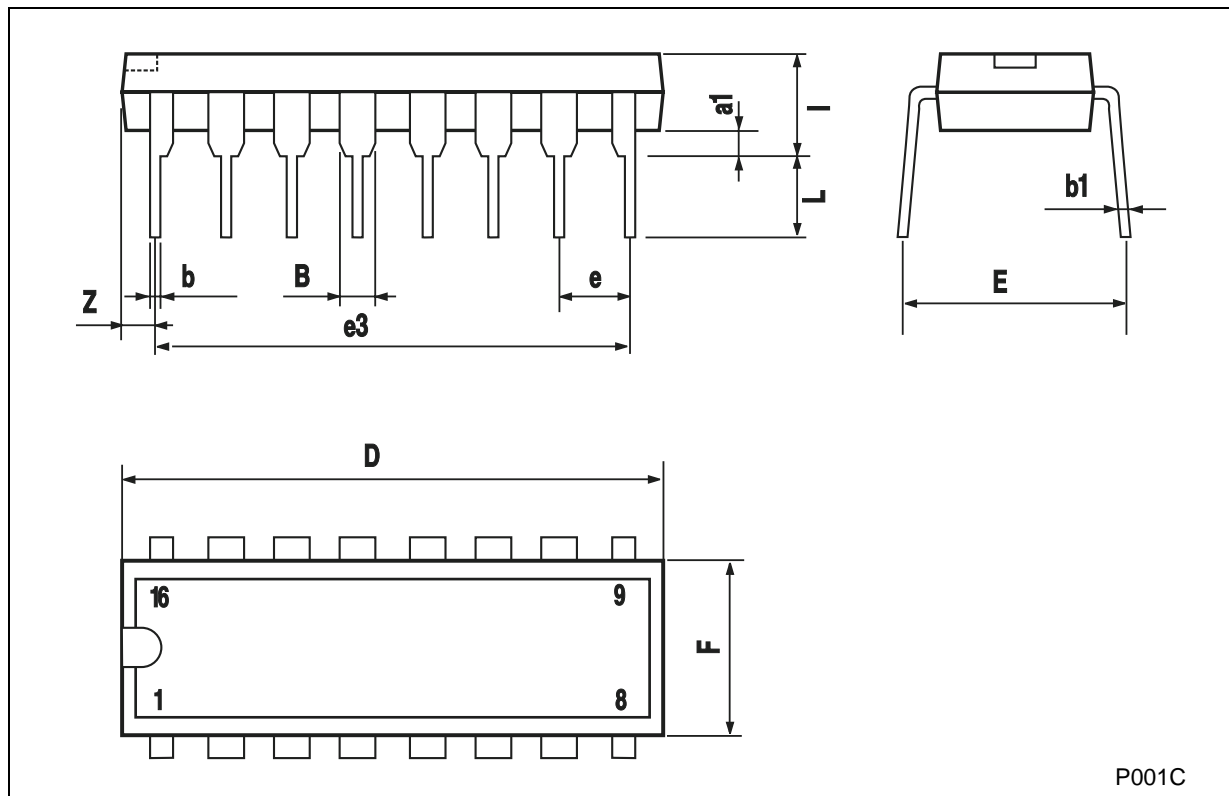

**SO-16 MECHANICAL DATA**

DIM.	mm.			inch		
	MIN.	TYP.	MAX.	MIN.	TYP.	MAX.
A			1.75			0.068
a1	0.1		0.2	0.003		0.007
a2			1.65			0.064
b	0.35		0.46	0.013		0.018
b1	0.19		0.25	0.007		0.010
C		0.5			0.019	
c1	45° (typ.)					
D	9.8		10	0.385		0.393
E	5.8		6.2	0.228		0.244
e		1.27			0.050	
e3		8.89			0.350	
F	3.8		4.0	0.149		0.157
G	4.6		5.3	0.181		0.208
L	0.5		1.27	0.019		0.050
M			0.62			0.024
S	8° (max.)					



PO13H



