

NL Series

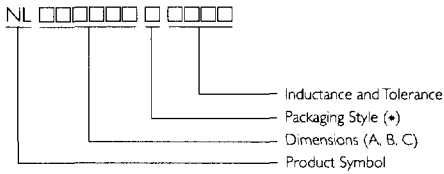

PRODUCT IDENTIFICATION



* B: Bulk; T: Tape and Reel

APPLICATIONS

Microtelevisions, liquid crystal televisions, video cameras, portable VCRs, car radios, car stereos, thin tape radios, television tuners, mobile telephones, radio and other electronic devices.

OUTLINE

These revolutionary, highly reliable wound chip inductors for automatic mounting have been developed in response to the trend toward high density in electronic equipment.

With metal terminals and a body of heat resistant resin, these inductors offer many superior features.

FEATURES

Very strong solderability by flow soldering, soldering iron or wave soldering.

Highly accurate dimensions; can be mounted automatically.

Terminals are highly resistant to pull forces.

Highly resistant to mechanical shocks and pressure.

Highly reliable in environments of sudden temperature change and humidity. Super Q characteristics.

SHAPES AND DIMENSIONS

Dimensions : mm

NL 322522

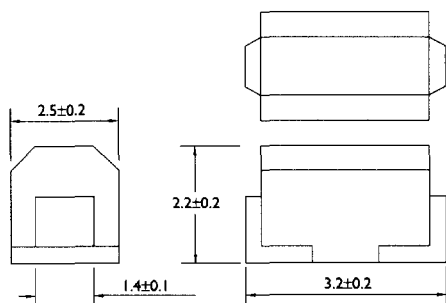

NL 453232

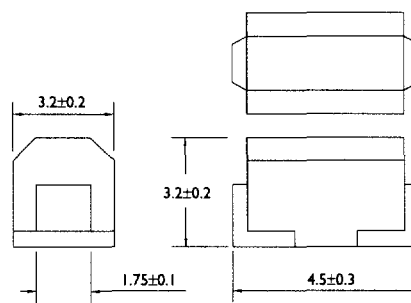

ELECTRICAL CHARACTERISTICS : NL322522 SERIES

PART NO.	L (μH)	Tolerance (\pm%)	Q Min.	Test Frequency (MHz)	SRF (MHz) Min.	RDC (Ω) Max.	IDC (mA)
NL322522T-R10M	0.10	20%	28	25.20	450	0.25	450
NL322522T-R22M	0.22	20%	30	25.20	350	0.32	450
NL322522T-R33M	0.33	20%	30	25.20	300	0.40	450
NL322522T-R39M	0.39	20%	30	25.20	250	0.45	450
NL322522T-R68M	0.68	20%	30	25.20	160	0.60	450
NL322522T-1R0K	1.0	10%	30	7.960	120	0.70	400
NL322522T-1R2K	1.2	10%	30	7.960	100	0.75	390
NL322522T-1R5K	1.5	10%	30	7.960	85	0.85	370
NL322522T-1R8K	1.8	10%	30	7.960	80	0.90	350
NL322522T-2R2K	2.2	10%	30	7.960	75	1.00	320
NL322522T-2R7K	2.7	10%	30	7.960	70	1.10	290
NL322522T-3R3K	3.3	10%	30	7.960	60	1.20	260
NL322522T-3R9K	3.9	10%	30	7.960	55	1.30	250
NL322522T-4R7K	4.7	10%	30	7.960	50	1.50	220
NL322522T-5R6K	5.6	10%	30	7.960	47	1.60	200
NL322522T-6R8K	6.8	10%	30	7.960	43	1.80	180
NL322522T-8R2K	8.2	10%	30	7.960	40	2.00	170
NL322522T-100K	10	10%	30	2.520	36	2.10	150
NL322522T-120K	12	10%	30	2.520	33	2.50	140
NL322522T-150K	15	10%	30	2.520	30	2.80	130
NL322522T-180K	18	10%	30	2.520	27	3.30	120
NL322522T-220K	22	10%	30	2.520	25	3.70	110
NL322522T-270K	27	10%	30	2.520	20	5.00	80
NL322522T-330K	33	10%	30	2.520	17	5.60	70
NL322522T-390K	39	10%	30	2.520	16	6.40	65
NL322522T-470K	47	10%	30	2.520	15	7.00	60
NL322522T-560K	56	10%	30	2.520	13	8.00	55
NL322522T-680K	68	10%	30	2.520	12	9.00	50
NL322522T-820K	82	10%	30	2.520	11	10.0	45
NL322522T-101K	100	10%	20	0.796	10	10.0	40
NL322522T-121K	120	10%	20	0.796	10	11.0	70
NL322522T-151K	150	10%	20	0.796	8	15.0	65
NL322522T-181K	180	10%	20	0.796	7	17.0	60
NL322522T-221K	220	10%	20	0.796	7	21.0	50

Test Instruments : HP 4291A RF Impedance Analyzer for L,Q,SRF
 HP 4292A LF Impedance Analyzer for L,Q

Digital Multimeter SC-7401 for RDC
 HP4261A LCR Digital Meter for IDC



ELECTRICAL CHARACTERISTICS : NL453232 SERIES

PART NO.	L (μ H)	Tolerance ($\pm\%$)	Q Min.	Test Frequency (MHz)	SRF (MHz) Min.	RDC (Ω) Max.	IDC (mA)
NL453232T-R10M	0.10	20	28	25.2	700	0.44	450
NL453232T-R12M	0.12	20	30	25.2	500	0.22	450
NL453232T-R15M	0.15	20	30	25.2	450	0.25	450
NL453232T-R18M	0.18	20	30	25.2	400	0.28	450
NL453232T-R22M	0.22	20	30	25.2	350	0.32	450
NL453232T-R27M	0.27	20	30	25.2	320	0.36	450
NL453232T-R33M	0.33	20	30	25.2	300	0.40	450
NL453232T-R39M	0.39	20	30	25.2	350	0.45	450
NL453232T-R47M	0.47	20	30	25.2	220	0.50	450
NL453232T-R56M	0.56	20	30	25.2	180	0.55	450
NL453232T-R68M	0.68	20	30	25.2	160	0.60	450
NL453232T-R82M	0.82	20	30	25.2	140	0.67	450
NL453232T-I10K	1.0	10	50	7.96	100	0.50	450
NL453232T-I12K	1.2	10	50	7.96	80	0.55	430
NL453232T-I15K	1.5	10	50	7.96	70	0.60	410
NL453232T-I18K	1.8	10	50	7.96	60	0.65	390
NL453232T-I22K	2.2	10	50	7.96	55	0.70	380
NL453232T-I27K	2.7	10	50	7.96	50	0.75	370
NL453232T-I33K	3.3	10	50	7.96	45	0.80	355
NL453232T-I39K	3.9	10	50	7.96	40	0.90	330
NL453232T-I47K	4.7	10	50	7.96	35	1.00	315
NL453232T-I56K	5.6	10	50	7.96	33	1.10	300
NL453232T-I68K	6.8	10	50	7.96	27	1.20	285
NL453232T-I82K	8.2	10	50	7.96	25	1.40	270
NL453232T-I100K	10	10	50	2.52	20	1.60	250
NL453232T-I120K	12	10	50	2.52	18	2.00	225
NL453232T-I150K	15	10	50	2.52	17	2.50	200
NL453232T-I180K	18	10	50	2.52	15	2.80	190
NL453232T-I220K	22	10	50	2.52	13	3.20	180
NL453232T-I270K	27	10	50	2.52	12	3.60	170
NL453232T-I330K	33	10	50	2.52	11	4.00	160
NL453232T-I390K	39	10	50	2.52	10	4.50	150
NL453232T-I470K	47	10	50	2.52	10	5.00	140
NL453232T-I560K	56	10	50	2.52	9	5.50	135
NL453232T-I680K	68	10	50	2.52	9	6.00	130
NL453232T-I820K	82	10	50	2.52	8	7.00	120
NL453232T-I101K	100	10	40	0.796	7	8.00	110
NL453232T-I121K	120	10	40	0.796	6	8.00	110
NL453232T-I151K	150	10	40	0.796	5	9.00	105
NL453232T-I181K	180	10	40	0.796	5	9.50	102
NL453232T-I221K	220	10	40	0.796	4	12.0	100
NL453232T-I271K	270	10	30	0.796	3	18.0	92
NL453232T-I331K	330	10	30	0.796	3	20.0	85
NL453232T-I391K	390	10	30	0.796	3	23.0	80
NL453232T-I471K	470	10	30	0.796	3	26.0	62
NL453232T-I561K	560	10	30	0.796	2	30.0	50
NL453232T-I681K	680	10	30	0.796	2	40.0	50
NL453232T-I821K	820	10	30	0.796	2	45.0	30
NL453232T-I102K	1000	10	30	0.796	2	50.0	30

Note :

TAPE DIMENSIONS

Dimensions : mm

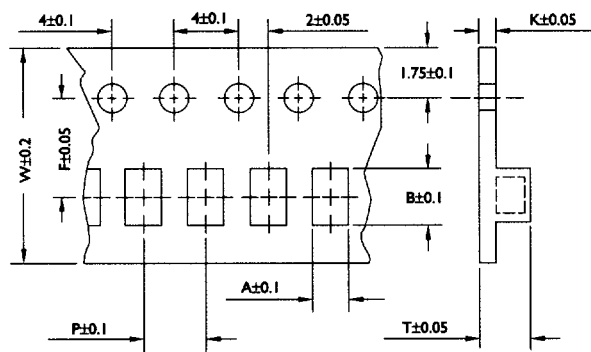

TYPE	A	B	T	W	P	F	K
NL322522	2.94	3.64	2.52	8	4	3.5	0.2
NL453232	3.64	5.14	3.6	12	8	5.5	0.3

REEL DIMENSIONS

Dimensions : mm

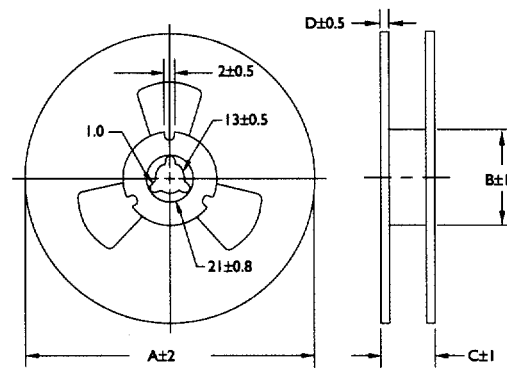

TYPE	A	B	C	D
NL322522	178	60	10	2
NL453232	250	80	14	2

RECOMMENDED PATTERN

Dimensions : mm(inches)

PARALLEL NL322522

SERIES

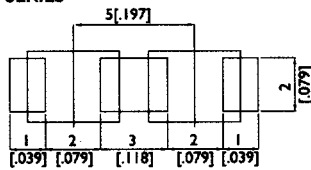
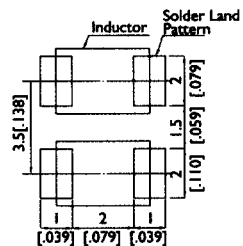

FOR NL453232 PC BOARD PATTERNS

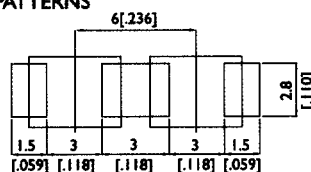
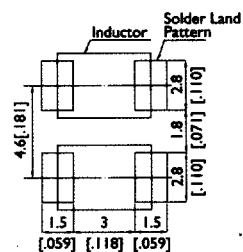

TAPE MATERIAL

Carrier Tape: Polystyrene
Cover Type: Polyethyiene

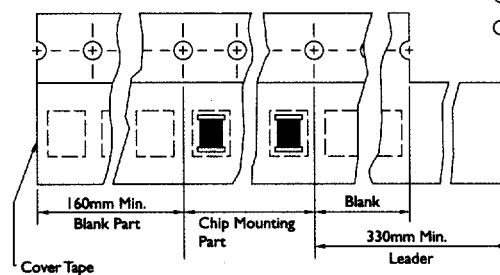

PACKAGING QUANTITY

TYPE	BULK	CHIP/REEL
NL322522	√	2000
NL453232	√	500

Note :

TYPICAL ELECTRICAL CHARACTERISTICS : NL453232 SERIES

