



## DUAL 2-WIDE 2-INPUT / 3-INPUT AND-OR- INVERT GATE

### DESCRIPTION

The T54LS51/T74LS51 is a high speed DUAL 2-WIDE 2-INPUT / 3-INPUT AND-OR INVERT GATE fabricated in LOW POWER SCHOTTKY technology.

**B1**  
Plastic Package

**D1/D2**  
Ceramic Package

**M1**  
Micro Package

**C1**  
Plastic Chip Carrier

**ORDERING NUMBERS:**  
 T54LS51 D2      T74LS51 C1  
 T74LS51 D1      T74LS51 M1  
 T74LS51 B1

### PIN CONNECTION (top view)

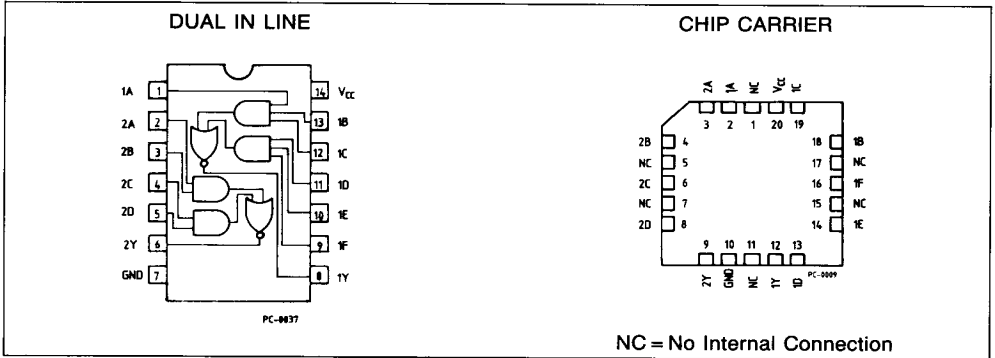

### SCHEMATIC

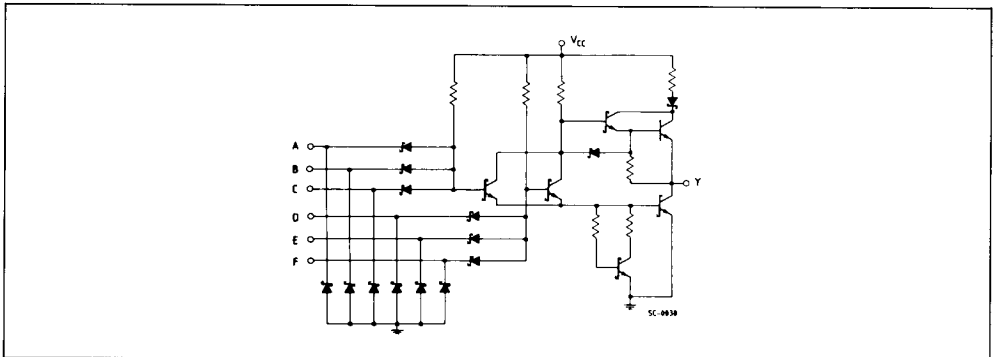

## LOGIC DIAGRAMS

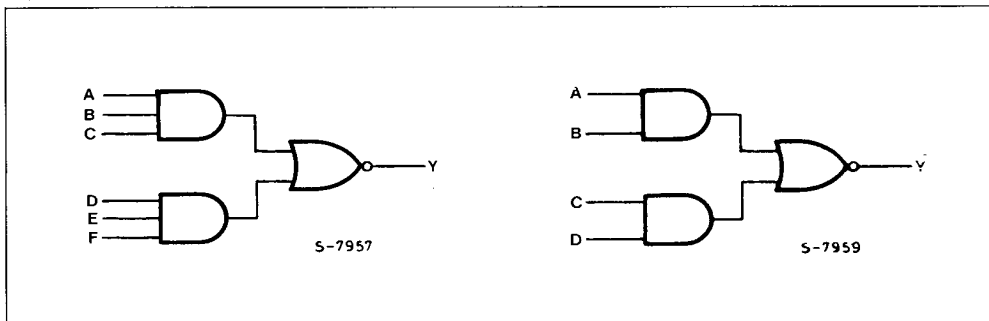

## ABSOLUTE MAXIMUM RATINGS

Symbol	Parameter	Value	Unit
$V_{CC}$	Supply Voltage	-0.5 to 7	V
$V_I$	Input Voltage, Applied to Input	-0.5 to 15	V
$V_O$	Output Voltage, Applied to Output	-0.5 to 5.5	V
$I_I$	Input Current, Into Inputs	-30 to 5	mA
$I_O$	Output Current, Into Outputs	50	mA

Stresses in excess of those listed under "Absolute Maximum Ratings" may cause permanent damage to the device. This is a stress rating only and functional operation of the device at these or any other conditions in excess of those indicated in the operational sections of this specification is not implied. Exposure to absolute maximum rating conditions for extended periods may affect device reliability.

## GUARANTEED OPERATING RANGES

Part Numbers	Supply Voltage			Temperature
	Min	Typ	Max	
T54LS51D2	4.5 V	5.0 V	5.5 V	-55°C to +125°C
T74LS51XX	4.75 V	5.0 V	5.25 V	0°C to +70°C

XX = package type.

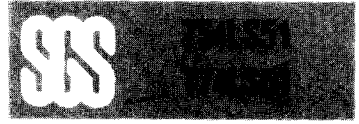

### DC CHARACTERISTICS OVER OPERATING TEMPERATURE RANGE

Symbol	Parameter	Limits			Test Conditions (Note 1)	Units
		Min.	Typ.	Max.		
V <sub>IH</sub>	Input HIGH Voltage	2.0			Guaranteed input HIGH Voltage	V
V <sub>IL</sub>	Input LOW Voltage	54		0.7	Guaranteed input LOW Voltage	V
		74		0.8		
V <sub>CD</sub>	Input Clamp Diode Voltage		-0.65	-1.5	V <sub>CC</sub> = MIN, I <sub>IN</sub> = -18mA	V
V <sub>OH</sub>	Output HIGH Voltage	54	2.5	3.4	V <sub>CC</sub> = MIN, I <sub>OH</sub> = -400μA, V <sub>IN</sub> = V <sub>IL</sub>	V
		74	2.7	3.4		
V <sub>OL</sub>	Output LOW Voltage	54,74		0.25	I <sub>OL</sub> = 4.0mA	V <sub>CC</sub> = MIN, V <sub>IN</sub> = 2.0V
		74		0.35	I <sub>OL</sub> = 8.0mA	
I <sub>IH</sub>	Input HIGH Current		1.0	20 0.1	V <sub>CC</sub> = MAX, V <sub>IN</sub> = 2.7V V <sub>CC</sub> = MAX, V <sub>IN</sub> = 7.0V	μA mA
I <sub>IL</sub>	Input LOW Current			-0.4	V <sub>CC</sub> = MAX, V <sub>IN</sub> = 0.4V	mA
I <sub>OS</sub>	Output Short Circuit Current (Note 2)	-20		-100	V <sub>CC</sub> = MAX, V <sub>OUT</sub> = 0V	mA
I <sub>CCH</sub>	Supply Current HIGH		0.8	1.6	V <sub>CC</sub> = MAX, V <sub>IN</sub> = 0V	mA
I <sub>CCL</sub>	Supply Current LOW		1.4	2.8	V <sub>CC</sub> = MAX, Inputs Open	mA

### AC CHARACTERISTICS: T<sub>A</sub> = 25°C (See page 576 for AC test circuit and waveforms)

Symbol	Parameter	Limits			Test Conditions	Units
		Min.	Typ.	Max.		
t <sub>PLH</sub>	Turn Off Delay, Input to Output		12	20	V <sub>CC</sub> = 5.0V	ns
t <sub>PHL</sub>	Turn On Delay, Input to Output		12.5	20	C <sub>L</sub> = 15pF	ns

**Notes:**

- 1) For conditions shown as MIN or MAX, use the appropriate value specified under guaranteed operating ranges.
- 2) Not more than one output should be shorted at a time.
- 3) Typical values are at V<sub>CC</sub> = 5.0V, T<sub>A</sub> = 25°C.